

LFH At-grade Treatment System

This design worksheet was developed by Alberta Municipal Affairs and
Alberta Onsite Wastewater Management Association

The complete system is to comply with the Saskatchewan Onsite Wastewater Disposal Guide
2018

This worksheet may NOT consider ALL of the requirements of the 2018 SOWDG

Use only Imperial units of measurements throughout this worksheet (feet, inches, Imperial gallons, etc.)

Use the following Worksheet to determine the Minimum required dimensions for an LFH At-grade and fill in the blanks on the appropriate diagram below for a level site or a sloping site of over 1% slope

THE TERMS USED IN THIS DRAWING DESCRIBE SPECIFIC AREAS OF THE LFH AT-GRADE AND ARE USED IN THE FOLLOWING WORKSHEET

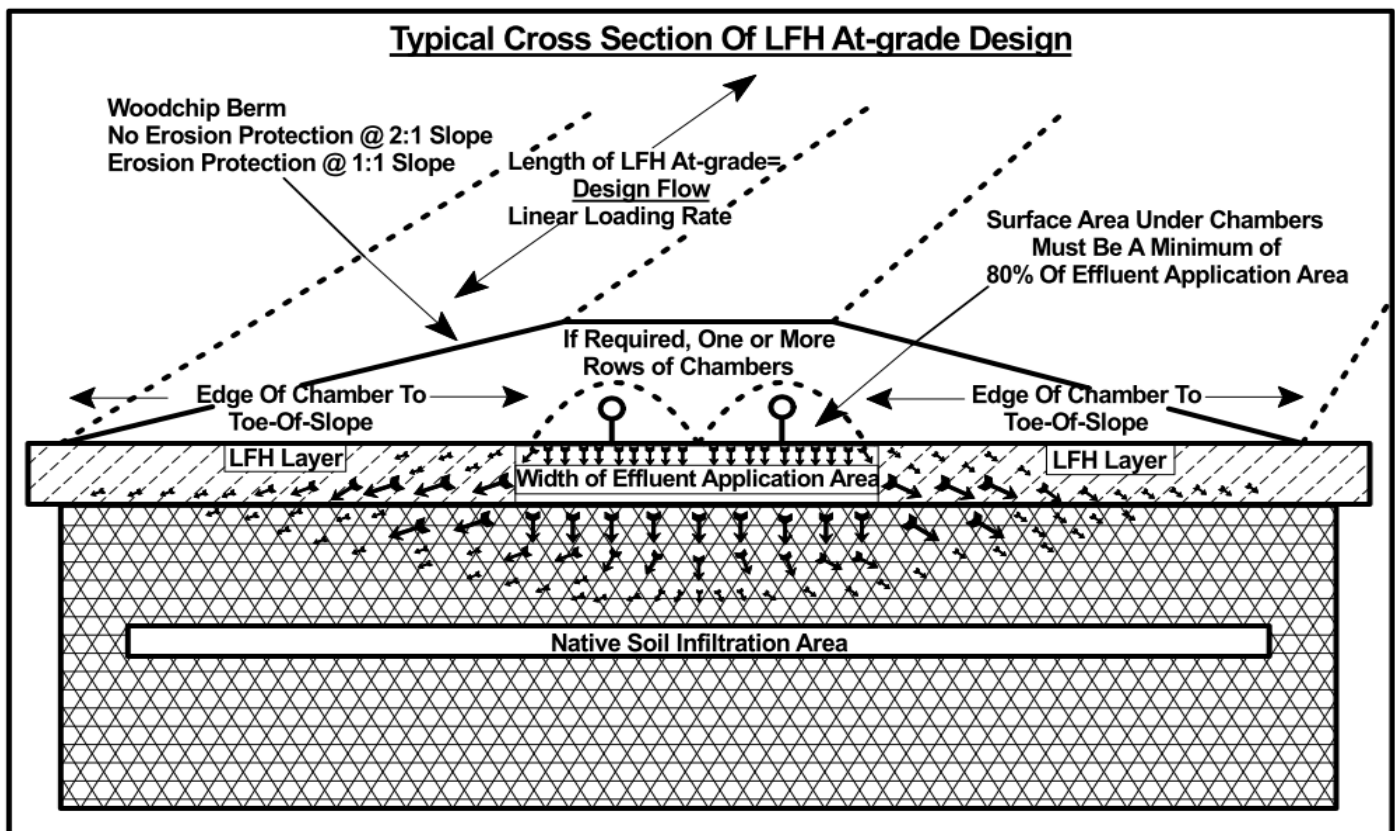

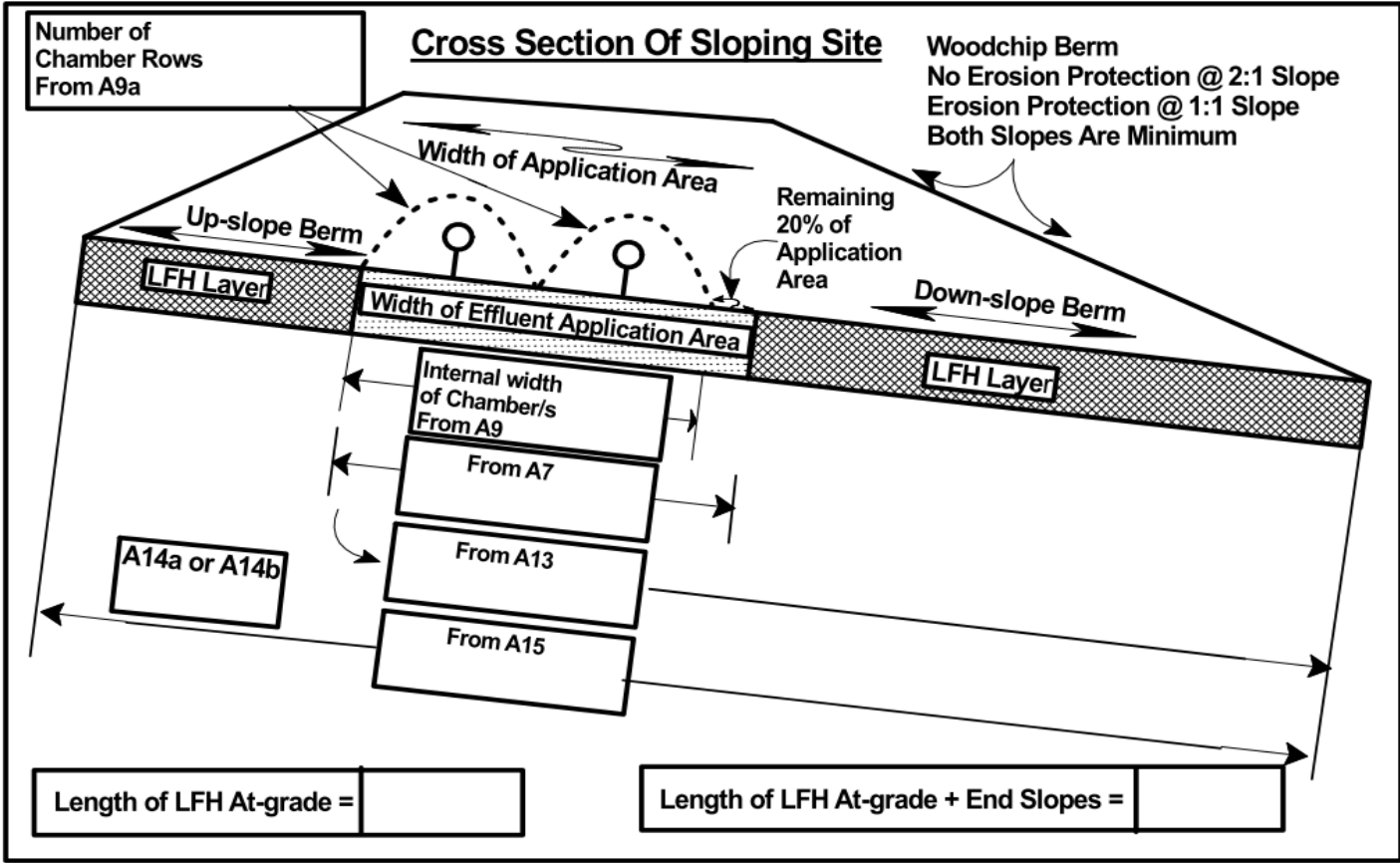
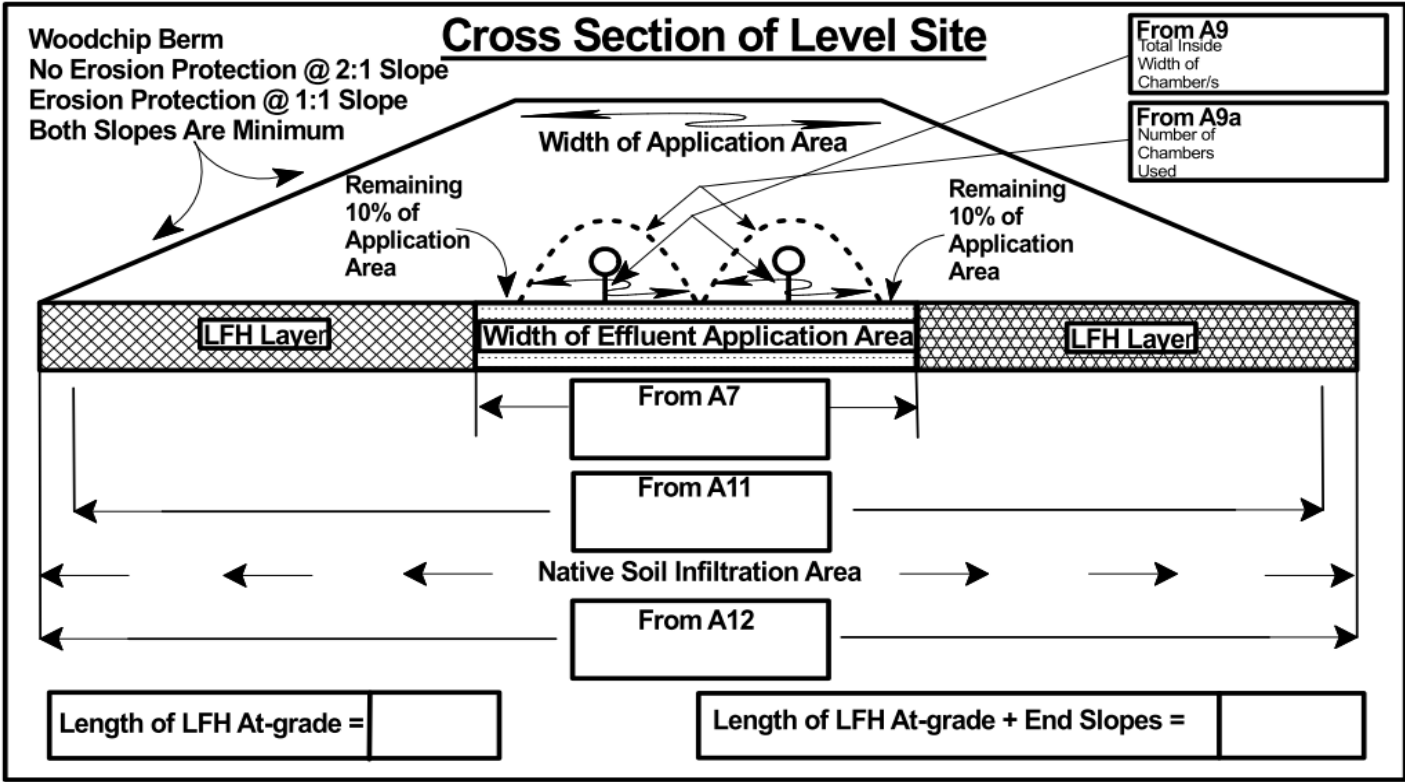

Step 1) Determine the expected peak volume of sewage per day:

Expected Peak Volume of Sewage per Day

A1

Gals. per day

Step 2) Determine the slope criteria of the installation site:

Note: If the slope of the installation site exceeds 1% use the drawing "sloped site". If there is no slope, use the drawing "level site" 1% or less.

Slope of Installation Site

%

A2

Step 3) Determine Effluent Hydraulic Loading Rate on Native Soil:

From site evaluation information the following is needed to be determined: 1) Soil Texture, 2) Soil Structure, 3) Grade. Based on those soil characteristics, determine the hydraulic effluent loading on the native soil.

Use the hydraulic effluent loading rates for effluent quality of <30 mg/L BOD as required

Hydraulic Effluent Loading Rate on Native Soil

A3

Gal./ day/ft²

Step 4) Determine the Hydraulic Linear Loading Rate on Native Soil:

From site evaluation information the following needs to be determined: 1) Soil Texture, 2) Soil Structure, 3) Grade of structure, 4) Depth of infiltration distance. Use that criteria to determine the allowed Hydraulic Linear Loading Rate.

Hydraulic Linear Loading Rate

A4

Gal./day/ft

Step 5) Determine Length of LFH At-grade:

Expected Peak Volume of Sewage Per Day

From A1

÷

Hydraulic Linear Loading Rate

From A4

Equals

Minimum Length of LFH At-grade

A5

Lineal Feet

Step 6) Calculate Effluent Application Surface Area Required

Expected Peak Volume of Sewage Per Day

From A1

÷

0.83

0.83 gal/sq. ft./day

Equals

Total Minimum Effluent Application Area

A6

Sq. Ft.

Step 7) Determine Minimum Width of Effluent Application Area:

Effluent Application Area <input style="width: 100%; height: 20px;" type="text"/> Sq. Ft From A6	÷	Minimum Length of At-grade from Box A5 <input style="width: 100%; height: 20px;" type="text"/> A7a A length exceeding A5 can be selected to result in narrower width required under chambers	Equals	Minimum Width of Effluent Application Area <input style="width: 100%; height: 20px;" type="text"/> A7 Ft.
---	---	---	--------	--

Step 8) Determine Minimum Internal Open Width of Chambers: (the internal width covered by a chamber or # of chambers)

Minimum Effluent Application Width <input style="width: 100%; height: 20px;" type="text"/> Ft. From A7	X	Apply Allowed Reduction factor. Actual open area of chambers must cover 80% of total Application area <input style="width: 100%; height: 20px; text-align: center; value: 0.8;" type="text"/>	Equals	Minimum Actual Internal Open Width Provided by Chamber(s) <input style="width: 100%; height: 20px;" type="text"/> A8 Ft.
--	---	---	--------	---

Step 9) Select the Chamber(s) to be Used and Number of Rows of Chambers Required:

Width of selected chamber in FEET - enter actual internal effective width (not manufacturer's outside dimensions) <input style="width: 100%; height: 20px;" type="text"/> Example: 19 inches divided by 12 inches = 1.6 feet 31 inches divided by 12 inches = 2.6 feet	X	Number of chamber row(s) selected <input style="width: 100%; height: 20px;" type="text"/> A9a	=	Actual width of open area provided by chambers for effluent application area <input style="width: 100%; height: 20px;" type="text"/> A9 Ft. This amount cannot be less than A8
---	---	---	---	--

Step 10) Calculate minimum Native Soil Infiltration Surface Area: [this is the area to be covered by the woodchip cover and includes the area under the chamber(s)]

Expected Peak Volume of Sewage Per Day <input style="width: 100%; height: 20px;" type="text"/> From A1	÷	Hydraulic Effluent Loading Rate <input style="width: 100%; height: 20px;" type="text"/> From A3	=	Minimum Required Native Soil Infiltration Area <input style="width: 100%; height: 20px;" type="text"/> A10 Sq. Ft.
---	---	---	---	---

Step 11) Determine Minimum Width of Native Soil Infiltration Area:

Native Soil Infiltration Area <input style="width: 100%; height: 20px;" type="text"/> From A10	÷	Length of At-grade Selected <input style="width: 100%; height: 20px;" type="text"/> From A7a	=	Minimum Width of Native Soil Infiltration Area <input style="width: 100%; height: 20px;" type="text"/> A11 Feet
--	---	--	---	--

Step 12) Cover Material Width of LFH At-grade; Site Slope 1% or Less.

Choose side slope of LFH At-grade cover material.

Toe to toe width based on 1:1 cover material slope

A7 + (2 X distance at 0% slope) from slope chart.

NOTE* 1:1 slopes are NOT Typical*

OR

Toe to toe width based on 2:1 cover material slope

A7 + (2 X distance at 0% slope) value from slope chart.

BUT NOT LESS THAN

Minimum Width of Required Native Soil Infiltration Area from A11

Minimum Width of At-grade Cover Material

A12

The Greater Value of the Width Based on Chosen Cover Material Slope or Box A11

Step 13) Minimum Width of Cover Material; Up-Slope Edge of Chambers to Downslope Toe of Cover Material - Site slope greater than 1%;

Choose Side Slope of LFH At-grade Cover Material;

1:1 Downslope Berm Distance (from slope chart)

+

Effluent Application Width From A7

=

A13a

2:1 Downslope Berm Distance (from slope chart)

+

Effluent Application Width From A7

=

A13b

Minimum Native Soil Infiltration Width From A11

Enter the Greater Width of: A13a, A13b, or A11

A13

Width of Cover Material From Up-slope Edge of Chambers to Downslope Toe of Cover Material

NOTE* 1:1 slopes are NOT Typical*

Step 14) Determine Width of Upslope Berm

1:1 Slope

A14a

Or

2:1 Slope

A14b

From Slope chart

From Slope chart

Step 15) Determine Toe to Toe Width of LFH At-Grade on Site Slope Greater Than 1%

Downslope Width

From A13

+

Upslope Width

From A14a or A14b

=

A15

Toe to Toe Width on Sites with Slope Greater Than 1 %

LFH At-grade Cover Material Width on 0% to 12% Sloped Sites

LFH At-grade Cover Material Slope Distance in Feet @ 1 :1 Berm slope

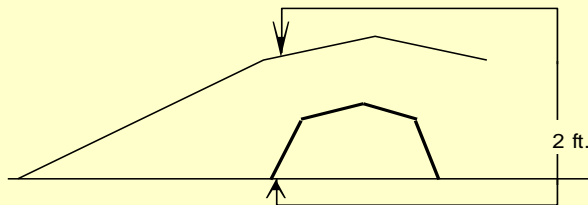
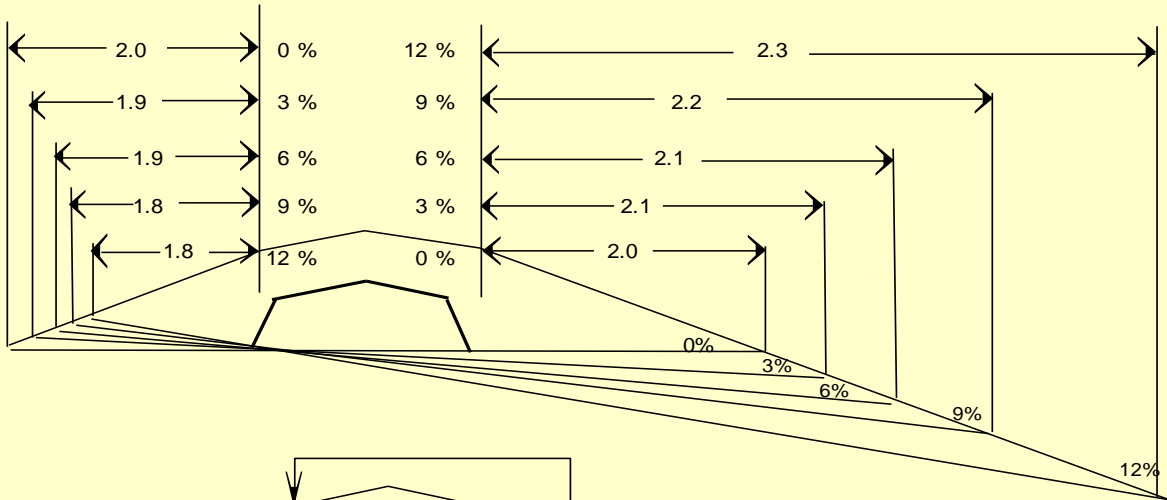

Height of LFH At-grade at edge of chamber(s)

Upslope Cover Material distance = Height of LFH At-grade at edge of chamber / (1.0 + [slope% / 100])

Downslope Cover Material Distance = Height of LFH At-grade at edge of chamber / (1.0 - [slope% / 100])

LFH At-grade Cover Material Slope Distance in Feet @ 2 :1 Berm slope

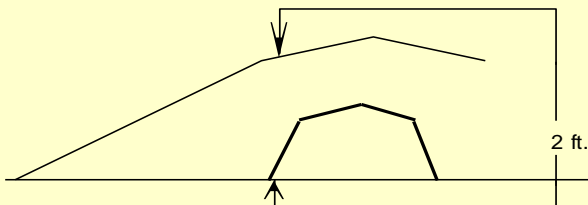
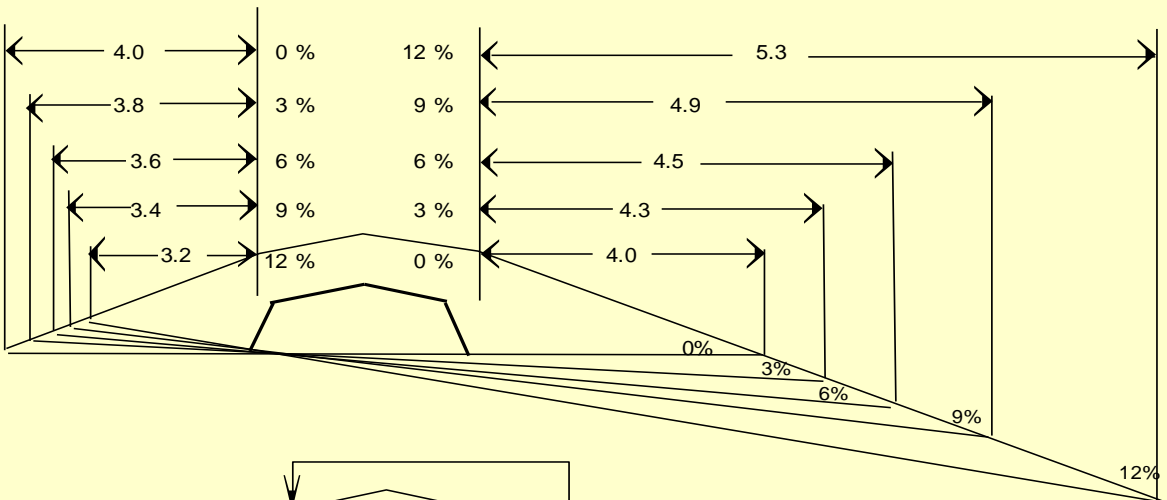

Height of LFH At-grade at edge of chamber(s)

Upslope Cover Material distance = Height of LFH At-grade at edge of chamber / (0.5 + [slope% / 100])

Downslope Cover Material Distance = Height of LFH At-grade at edge of chamber / (0.5 - [slope% / 100])