

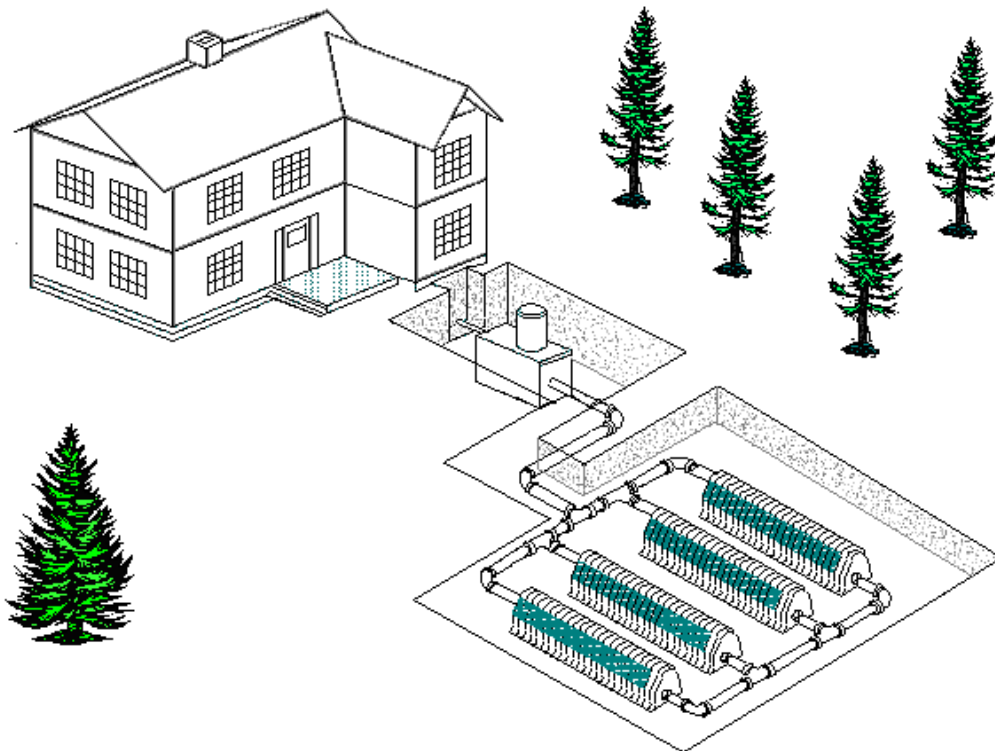

Saskatchewan
Ministry of
Health

SASKATCHEWAN ONSITE WASTEWATER DISPOSAL GUIDE



*Second Edition
January 2009*

TABLE OF CONTENTS

1.0	INTRODUCTION	I-1
2.0	PERMITS	II-1
3.0	THE SHORELAND POLLUTION CONTROL REGULATIONS, 1976	III-1
4.0	PRIVATE SEWAGE WORKS IN SENSITIVE AREAS	IV-1
4.1	Description of Sensitive Areas.....	IV-1
4.1.1	Location	IV-1
4.1.2	Density	IV-2
4.2	Site Investigations.....	IV-4
4.2.1	Basic Site Investigation.....	IV-4
4.2.2	Detailed Site Investigation.....	IV-5
4.3	Permissible Solutions	IV-6
5.0	HOLDING TANKS	
5.1	DEFINITION	V-1
5.2	FUNCTION	V-1
5.3	DESIGN	V-1
5.3.1	Capacity	V-2
5.3.2	Tank Construction.....	V-2
5.3.3	Tank Access.....	V-3
5.3.4	Water Tightness	V-3
5.4	INSTALLATION	V-3
5.4.1	Site Selection	V-3
5.4.2	Setback Requirements.....	V-4
5.4.3	Inspection.....	V-4
5.5	CARE AND MAINTENANCE	V-5
6.0	SEPTIC TANKS	
6.1	DEFINITION	VI-1
6.2	FUNCTION	VI-1
6.2.1	Removal Of Solids.....	VI-1
6.2.2	Biological Treatment	VI-2
6.2.3	Sludge And Scum Storage	VI-2

6.3	DESIGN	VI-2
6.3.1	Capacity	VI-2
6.3.2	Tank Construction.....	VI-3
6.3.3	Inlets and Outlets	VI-5
6.3.4	Tank Access	VI-6
6.3.5	Water Tightness	VI-6
6.3.6	Compartmentalized Tanks	VI-7
6.3.7	Special Considerations.....	VI-7
	• Restaurants.....	VI-7
	• Laundromats	VI-7
	• Slaughterhouses	VI-7
	• Milk House Waste.....	VI-7
6.4	INSTALLATION	VI-8
6.4.1	Site Selection	VI-8
6.4.2	Excavations for Septic Tanks	VI-9
6.4.3	Setback Requirements.....	VI-10
6.4.4	Inspection.....	VI-10
6.5	CARE AND MAINTENANCE	VI-10

7.0 CHAMBER SYSTEMS

7.1	DEFINITION	VII-1
7.2	FUNCTION	VII-1
7.3	DESIGN	VII-1
7.3.1	Conventional Gravity Flow Chamber System	VII-3
7.3.2	Gravity Chamber System with Pressurized Delivery	VII-3
7.3.3	Pressure Chamber System.....	VII-4
7.3.4	Sizing The System	VII-5
7.3.5	Calculating System Size Using Soil Texture Classification Method	VII-6
7.4	INSTALLATION	VII-8
7.4.1	Site Selection	VII-8
7.4.2	Setback Requirements.....	VII-8
7.4.3	Inspection.....	VII-8
7.5	CARE AND MAINTENANCE	VII-8

8.0 ABSORPTION FIELD SYSTEMS

8.1	DEFINITION	VIII-1
8.2	FUNCTION	VIII-1
8.3	DESIGN	VIII-2
8.3.1	Gravity Effluent Distribution Systems.....	VIII-9
8.3.2	Pressure Effluent Distribution Systems	VIII-9
8.3.3	Sizing The System	VIII-9
	8.3.3.1 Calculating System Size Using Soil Percolation Test	VIII-10
	8.3.3.2 Calculating System Size Using Soil Texture Classification Method	VIII-11

8.4	INSTALLATION	VIII-12
8.4.1	Site Selection	VIII-12
8.4.2	Setback Requirements.....	VIII-13
8.4.3	Inspection.....	VIII-13
8.5	CARE AND MAINTENANCE	VIII-13
9.0	MOUNDS	
9.1	TYPE I MOUNDS.....	IX-1
9.1.1	DEFINITION	IX-1
9.1.2	FUNCTION	IX-2
9.1.3	DESIGN	IX-2
	9.1.3.1 Sizing The System	IX-2
9.1.4	INSTALLATION	IX-9
	9.1.4.1 Site Solution.....	IX-9
	9.1.4.2 Soil Depth	IX-9
	9.1.4.3 Setback Requirements.....	IX-9
	9.1.4.4 Inspection.....	IX-10
9.1.5	CARE AND MAINTENANCE	IX-10
9.2	TYPE II MOUNDS	IX-11
9.2.1	DEFINITION	IX-11
9.2.2	FUNCTION	IX-12
9.2.3	DESIGN	IX-12
	9.2.3.1 Sizing The System	IX-16
	9.2.3.2 Calculating System Size Using Soil Percolation Test or Soil Texture Classification Method.....	IX-18
	9.2.3.3 Pressure Distribution Lateral Design	IX-20
9.2.4	INSTALLATION	IX-21
	9.2.4.1 Site Selection	IX-21
	9.2.4.2 Soil Depth	IX-21
	9.2.4.3 Setback Requirements.....	IX-22
	9.2.4.4 Inspection.....	IX-22
9.2.5	CARE AND MAINTENANCE	IX-23
10.0	JET TYPE DISPOSAL SYSTEMS	
10.1	DEFINITION	X-1
10.2	FUNCTION	X-1
10.3	DESIGN	X-1
	10.3.1 Ejector System	X-1
	10.3.2 Surface Discharge System	X-2
10.4	INSTALLATION	X-3
	10.4.1 Site Selection	X-3
	10.4.2 Setback Requirements.....	X-3
	10.4.3 Inspection.....	X-4
10.5	CARE AND MAINTENANCE	X-4

11.0 LAGOONS

11.1 DEFINITION XI-1

11.2 FUNCTION XI-1

 11.2.1 Anaerobic Lagoons XI-2

 11.2.2 Aerobic Lagoons XI-2

 11.2.3 Facultative Lagoons XI-2

 11.2.4 Aerated Lagoons XI-3

 11.2.5 Advantages XI-3

 11.2.6 Disadvantages XI-4

 11.2.7 In Series Versus In Parallel Lagoon Systems XI-4

11.3 DESIGN XI-4

 11.3.1 Capacity XI-5

 11.3.2 Sizing For Lagoons That Are Intended To Be Discharged XI-5

 11.3.3 Sizing For Lagoons That Are Not Intended To Be Discharged XI-7

 11.3.4 Lagoon Construction XI-7

11.4 INSTALLATION XI-11

 11.4.1 Site Selection XI-11

 11.4.2 Setback Requirements XI-11

 11.4.3 Inspection XI-11

11.5 CARE AND MAINTENANCE XI-12

 11.5.1 Common Problems XI-13

 11.5.2 Safety XI-13

12.0 PACKAGE SEWAGE TREATMENT PLANTS

12.1 DEFINITION XII-1

12.2 FUNCTION XII-1

12.3 DESIGN XII-1

12.4 INSTALLATION XII-2

 12.4.1 Setback Requirements XII-2

 12.4.2 Inspection XII-2

12.5 CARE AND MAINTENANCE XII-3

APPENDICES

APPENDIX 1	DISPOSAL FIELD DESIGN DATA	A-1
APPENDIX 2	EXPECTED VOLUME OF SEWAGE PER DAY	A-4
APPENDIX 3	TRENCH BOTTOM SYSTEM SIZING WORKSHEET	A-6
APPENDIX 3A	PRESSURE CHAMBER SYSTEM WORKSHEET	A-8
APPENDIX 4	NUMBER OF ORIFICES IN A DISTRIBUTION LATERAL PIPE	A-13
APPENDIX 5	ORIFICE DISCHARGES IN LITRES PER MINUTE	A-17
APPENDIX 6	FRICTION LOSS FOR PIPING	A-18
APPENDIX 7	TYPE II MOUND: AREA SIZING	A-22
APPENDIX 7A	TYPE I MOUND: AREA SIZING	A-29
APPENDIX 8	HOW TO CONDUCT A PERCOLATION TEST	A-31
APPENDIX 9	PROCEDURE FOR HAND TEXTURING A SOIL SAMPLE	A-33
APPENDIX 10	REPORT FORM – PERCOLATION TEST	A-34
APPENDIX 11	CONVERSION FACTORS	A-35
APPENDIX 12	SQUIRT TEST	A-36
APPENDIX 13	FRICTION LOSS FOR INSERT FITTINGS	A-37
APPENDIX 14	DISTRIBUTION BOX	A-38
APPENDIX 15	SOIL TESTS	A-43
APPENDIX 16	OPERATIONAL TIPS FOR SEPTIC SYSTEMS	A-51
APPENDIX 17	PRESSURE DISTRIBUTION: ORIFICE, PIPE AND PUMP SIZING	A-56
APPENDIX 18	MAPS	A-60
APPENDIX 19	EXAMPLE OF CALCULATION METHOD FOR DETERMINING LAGOON DIMENSIONS	A-62
APPENDIX 20	MINIMUM PARCEL/LOT SIZES AND SET BACK REQUIREMENTS	A-63
APPENDIX 21	DOSING	A-64
APPENDIX 22	TEST PITS	A-66
APPENDIX 23	CONSTRUCTION NOTES	A-67
APPENDIX 24	SEWER AND WATER LINE INSTALLATION	A-68

DEFINITIONS AND ABBREVIATIONS

Aquifer means any porous water-bearing geologic formation capable of yielding a supply of water.

Berm means the raised area as in a Type II mound, a sand filter or around a lagoon.

Biological Oxygen Demand or BOD₅ means the concentration of oxygen (expressed as mg/L) utilized by micro organisms in the oxidation of organic matter during a 5-day period at a temperature of 20°C (68°F).

Building means any structure used or intended for supporting or sheltering any use or occupancy.

Building Drain means the horizontal piping including any vertical offset that conducts sewage, clear-water waste or storm water in a building to a building sewer.

Building Sewer means a pipe connected to a building drain starting 1 m (3.25 ft) outside a wall of a building and that leads to a public sewer or private sewage system.

Certified means tested by a nationally recognized testing agency and Certified as conforming to a National Standard of Canada or other Standard recognized by the Administrator.

Clear-Water Waste means waste water with impurity levels that will not be harmful to health and may include cooling water and condensate drainage from refrigeration and air conditioning equipment and cooled condensate from steam heating systems, but does not include storm water.

Diameter, unless otherwise indicated, means the nominal diameter by which a pipe, fitting, trap or other item is commercially designated.

Distribution Header means a non-perforated pipe connected to an effluent line from a septic tank which distributes effluent to distribution laterals, weeping lateral pipes or weeping lateral trenches.

Distribution Lateral Pipe means a perforated pressurized pipe used to distribute effluent throughout the entire length of a weeping lateral trench or over a surface area in a sand filter or mound.

Drain Media (as used in a sand filter) means clean washed gravel, clean crushed rock, or other media for distributing effluent.

Dwelling or Dwelling Unit means a suite operated as a housekeeping unit used, or intended to be used, as a domicile by one or more persons and usually contains cooking, eating, living, sleeping and sanitary facilities.

Effluent means the discharge from any on-site sewage treatment component.

Effluent Sewer means piping for the flow of effluent through the action of gravity.

Field Header means a main weeping lateral pipe that also distributes effluent to other weeping lateral pipes in a level disposal field.

Filter Fabric means a synthetic woven or spun-bonded sheet material used to impede or prevent the movement of sand, silt and clay into the spaces between larger media but does not impede the movement of air or water.

Fines means silt or smaller soil particles which would pass through a 200 sieve, or are less than 80 microns in particle size.

Grade means the gradient, slope, or rate of ascent or descent.

High Water Level means the highest water level or mark of historical record or as may be determined by the local health region.

Mottling means a soil zone or chemical oxidation and reduction activity, appearing as splotchy patches of red, brown, orange or grey in the soil, that may indicate the presence of a water table.

Nominally Level means level, so as to not affect the performance of the system.

On-site means on the property.

Percolation Test means a test performed to determine a rate at which soil will absorb water.

Permit means permission or authorization in writing by the local authority (health region) to perform work regulated by **The Plumbing and Drainage Regulations**.

Potable means safe for human consumption.

Pressure Head means the pressure existing in a fluid expressed as the height of a column of water that would exert an equal pressure.

Private Sewage Works means a privately owned works located on one property, other than a pit privy or seepage pit, intended to be used for the reception, treatment and disposal or storage of sewage, effluent or both that does not contain industrial waste, and that has an average flow from the works, as determined by the local authority, that does not exceed 18 cubic metres per 24-hour period, based on the three consecutive months having the greatest flow in a year.

Property means the land described in the Certificate of Title issued under the Land Titles Act.

Recreational Area means:

- (i) a camp ground, institutional camp or tourist camp; or
- (ii) a regional park; or
- (iii) a provincial park; or
- (iv) a commercial facility for the accommodation of persons who are intending to ski, fish, or swim, or be engaged in other recreational activities while being so accommodated; or
- (v) a building or buildings being used or intended to be used for recreational purposes whether on a private or commercial basis and includes any such building whether occupied on a permanent or part-time basis.

Residential Strength Sewage means sewage which has a BOD₅ of less than 300 mg/L, T.S.S. of less than 350 mg/L, and oil and grease content of less than 25 mg/L.

Sand (when referring to a treatment or disposal component) means a soil texture composed of soil particulate defined for use in the component.

Sand Filter Media means the granular filter media used in the construction of a sand filter.

Sand Filter Surface Area means the area of the level plane section of the sand filter media in contact with the drain media containing the pressurized distribution piping.

Sand Layer (when referring to a Type II mound) means the required 300 mm (1 ft) layer of sand that will receive the effluent from a gravel bed or chambers above the sand layer.

Serial Distribution means a disposal field design where discharged effluent is forced to travel through one weeping lateral trench to get to another weeping lateral trench.

Sewage means any liquid waste other than clear-water waste or storm water.

Shore means the edge of a body of water and includes the land adjacent to a body of water that has been covered so long by water as to wrest it from vegetation or as to mark a distinct character on the vegetation where it extends into the water or on the soil itself.

Size unless otherwise indicated means the nominal size by which a pipe, fitting, trap or other item is commercially designated.

Soil Texture Classification means a classification of soil set out in Appendix 9 having a soil composition determined by Grain or Particle Size Analysis.

Storm Water means water discharged from a surface as a result of rainfall or snowfall.

Total Suspended Solids (T.S.S.) means the quantity of solids (expressed as mg/L) which can be readily removed from a well mixed sample with standard laboratory filtering procedures.

Vertical Separation means the depth of unsaturated soil between the bottom of an effluent disposal component and a limiting layer such as a water table or impervious layer of rock or soil.

Water Course means:

- (a) a river, stream, lake, creek, swamp, marsh or other natural body of water marked by the shore, or
- (b) a canal, reservoir or other manmade surface feature intended to contain water for a specified use, whether it contains or conveys water continuously or intermittently.

Water Table means the highest elevation in the soil where all voids are filled with water, as evidenced by the presence of water, soil mottling, or other indicators.

Weeping Lateral Pipe means the perforated pipe used to distribute effluent by gravity within a disposal field trench.

Weeping Lateral Trench means a trench in a disposal field that received effluent and provides an infiltrative soil surface.

Working Capacity means that part of the septic tank in which the liquid volume of *sewage* that will remain in the septic chamber when the tank is properly installed and is normal use, but does not include the air space, siphon chamber, pumping chamber or effluent chamber.

INTRODUCTION

The Saskatchewan Onsite Wastewater Disposal Guide has been put together with the assistance of inspection agencies and industry who have expertise in the field of wastewater disposal or treatment. This guide replaces the Saskatchewan Private Sewage Disposal Guide, 1995 and previous editions of the current Guide. The intent is to provide regulators and installers with basic design and installation information for private sewage works that are regulated by *The Plumbing and Drainage Regulations*.

DISCLAIMER

This Guide was prepared to assist persons wishing to construct and install a private sewage works. It is merely an illustrative and explanatory tool intended to provide a basic understanding of the regulatory framework in Saskatchewan respecting onsite wastewater systems and some basic information on the various systems. It is not intended as nor is it a substitute for technical or engineering advice and assistance, nor for individual assessment of things such as appropriate design; climatic conditions; effluent quality; wastewater flows and volumes; construction and installation requirements; and soil characteristics. Adjustments to separation distances and loading calculations may be required to reflect physical constraints, land area, soil, weather and any other environmental conditions.

This is not a permit and the information contained herein does not override, substitute or replace the requirements of *The Plumbing and Drainage Regulations* and all other applicable federal and provincial legislation and municipal bylaws.

The user of this Guide waives and discharges the authors of this Guide including the Government of Saskatchewan, the Regional Health Authorities of Saskatchewan and their respective employees, officers and agents from any claim they may have based upon use or reliance on this Guide. Notwithstanding the issuance of a permit, the approval of plans or specifications, approval or inspection or any other act of the local authority, the permit holder of the private sewage system is responsible to ensure that all work undertaken complies with the requirements of the *Public Health Act, 1994* and its regulations; manufacturer's requirements; and is completed a manner that does not cause an unacceptable impact on the environment or human health.

ACKNOWLEDGMENTS

The Saskatchewan Onsite Wastewater Disposal Guide Committee would like to acknowledge the following agencies/departments for the use of their reference material and for contributing to the development of this guide:

- | | |
|---|---|
| <input type="checkbox"/> Saskatchewan Ministry of Health | <input type="checkbox"/> Kelsey Trail Health Region |
| <input type="checkbox"/> Sun Country Health Region | <input type="checkbox"/> BC Ministry of Health |
| <input type="checkbox"/> Prince Albert Parkland Health Region | <input type="checkbox"/> Manitoba Conservation |
| <input type="checkbox"/> Regina Qu'Appelle Health Region | <input type="checkbox"/> Alberta Onsite Wastewater Management Association |
| <input type="checkbox"/> Saskatoon Health Region | |

SPECIAL ACKNOWLEDGMENTS

Special thanks to the Alberta Safety Codes Council and Alberta Municipal Affairs for their permission to use portions of the Alberta Private Sewage Systems Standard of Practice documents when developing this guide.

The Saskatchewan Onsite Wastewater Disposal Guide Second Edition 2008 is a Ministry of Health document intended to be used by stakeholders in the onsite wastewater industry. The document will be available for free download and printing on the Ministry of Health's website (<http://www.health.gov.sk.ca/wastewater-disposal-guide>). Re-printing of the guide is permitted provided that the Ministry of Health's visual identity aspects remain and the content is unchanged.

For more information please contact your local Health Region.

CYPRESS HEALTH REGION

350 Cheadle St. W.
Swift Current S9H 4G3

Phone: 778-5280

FAX: 778-5408

SUNRISE HEALTH REGION

150 Independent Street
Yorkton S3N 0S7

Phone: 786-0600

FAX: 786-0620

FIVE HILLS HEALTH REGION

107-110 Ominica St. W.
Moose Jaw S6H 6V2

Phone: 691-1500

FAX: 691-1523

PRAIRIE NORTH HEALTH REGION

Suite 101, 11427 Railway Avenue
North Battleford, SK S9A 3G8

Phone: 446-6400

FAX: 446-6432

SUN COUNTRY HEALTH REGION

Box 2003
Weyburn S4H 2Z9

Phone: 842-8618

FAX: 842-8637

PRINCE ALBERT PARKLAND HEALTH REGION

1521-6th Ave. W.
Prince Albert S6V 5K1

Phone: 765-6600

FAX: 765-6624

KELSEY TRAIL HEALTH REGION

Box 6500
Melfort S0E 1A0

Phone: 752-6310

FAX: 752-6353

REGINA QU'APPELLE HEALTH REGION

2110 Hamilton St. 2nd Floor
Regina S4P 2E3

Phone: 766-7755

FAX: 766-7730

HEARTLAND HEALTH REGION

Box 1300
Rosetown S0L 2V0

Phone: 882-6413

FAX: 882-6474

SASKATOON HEALTH REGION

#101-310 Idylwyld Dr. N.
Saskatoon S7L 0Z2

Phone: 655-4605

FAX: 655-4498

POPULATION HEALTH UNIT/KEEWATIN YATTHÉ/MAMAWETAN CHURCHILL RIVER REGIONAL HEALTH AUTHORITIES

Box 6000
La Ronge S0J 1L0

Phone: 425-8512

FAX: 425-8550

PERMITS

SEWAGE DISPOSAL IN SASKATCHEWAN

Private sewage works are installed where a plumbing system cannot be connected to a communal sewage works or municipal sewage works. In Saskatchewan, private sewage works are regulated by *The Plumbing and Drainage Regulations* in the case of small works (eg. a works connected to a house or small tourist accommodation facility) or *The Water Regulations, 2002* in the case of a large works (eg. a works connected to a large tourist accommodation facility that generates more than 18 m³ sewage flow per day).

Private sewage works regulations and guidelines are intended to minimize the impact of sewage effluent on water supplies, communities and neighbours. Most private sewage works are not just temporary installations that should be replaced eventually by centralized sewage treatment services, but permanent approaches to treating wastewater for release and reuse in the environment. Many private sewage works are recognized as potentially viable, low-cost, long-term, decentralized approaches to wastewater treatment if they are planned, designed, installed, operated, and maintained properly.

The Plumbing and Drainage Regulations, apply to all private sewage works in the Province of Saskatchewan. Portions of this regulation state:

5(1) No person shall establish, construct, extend, renovate, alter or repair a plumbing system or private sewage works, or connect a plumbing system to a communal sewage works or communal waterworks, except under the authority of a permit.

Applications for permits shall be made through the local health region and be accompanied by design specifics, location details and satisfactory evidence that the proposed private sewage works has been designed by a qualified person. Please see page II-2 & II-3 for an example of a permit.

The permit fee to install a private sewage works is \$30.00 payable to the local health region. Permit applications are available through the local health region.

Once the permit application is approved, the permit holder can proceed with construction of the private sewage works system. However, no portions of the private sewage works can be covered until the permit holder receives permission from the local Public Health Inspector. Normally, this involves an inspection of the completed system. The health regions request at least two business days notice for any inspection.

If you require any further information, please call your local health region. Please see page I - 2 for more information.

Regional Health Authority

Rural Plumbing/Sewage Disposal Permit Application

In compliance with the provisions of the Saskatchewan Plumbing and Drainage Regulations application is hereby made for permission to: Construct Reconstruct Extend Connect the: plumbing system private sewage works on the premises or property of:

Location of Installation City, Town or Village		Street	
Lot	Block	Plan	
R.M. #	Section	Township	Range West of Meridian
Plumber / Sewage Works Installer		Address Phone #	Certificate of Status # _____ <input type="checkbox"/> Journeyman <input type="checkbox"/> Other _____
Permit Applicant		Address Phone #	Signature
Property Owner		Mailing Address	

Plumbing System –Number of fixtures to be installed

Kitchen Sinks _____	Shower Stalls _____	Laundry Tubs _____
Lavatories _____	Bath Tubs _____	Clothes Washer _____
Water Closets _____	Floor Drains (No Charge) _____	Other Fixtures _____

No part of the plumbing system shall be covered until permission is granted by the Local Authority.

Private Sewage Works

- A. Expected Daily Sewage Volume (Litres) _____ # of Bedrooms _____
- B. Soil classification: Sand Loam Silt Clay Sandy/Loam
- C. Percolation Test: _____ minutes per 25 mm
- D. Depth to Water Table if less than 3 m from ground surface _____ m
- E. Septic Tank Holding Tank Size _____ gals/litres.
- F. Disposal Systems: Jet Type Disposal Absorption Field (size) _____ m² Other _____ m²
 Gravity Flow Chamber System Pressure Chamber System Chamber System (size) _____ m²
 # of Chamber Units _____ Size of each Chamber _____ m²
 Sewage Mound Type I (size) _____ m³ of clean graded stone. Sewage Mound Type II (size) _____ m².
 Lagoon (Storage capacity) _____ m³
- G. Detailed Site Plan to be provided on reverse side of public health officer copy

No part of the private sewage works shall be covered until permission is granted by the Local Authority.

Permit Fee

Total number of Fixtures _____	Fee \$ _____
Private Sewage Works _____	Fee \$ _____
Connection to Communal Sewage Works or Communal Waterworks _____	Fee \$ _____ Total _____

Detailed design work sheet required for this installation. Yes No Work sheet received (Date) _____

Permission is hereby granted to construct the work indicated above.

Signature of Local Authority _____

Date
Fee Received \$

Plumbing System

Date(s) Tested/Inspected _____

Approved _____
(Signature of Local Authority)

Regional Health Authority

Private Sewage Works

Date(s) Tested/Inspected _____

Approved _____
(Signature of Local Authority)

THE SHORELAND POLLUTION CONTROL REGULATIONS, 1976

(These regulations are currently under review. Please contact your local health region for information on any updates to these regulations.)

Parcels of property located within a shoreland development area must comply with sewage disposal restrictions outlined under *The Shoreland Pollution Control Regulations, 1976* (Table 1 in *The Shoreland Pollution Control Regulations, 1976*).

Shoreland Development Area is an area of land:

- ❑ designated as a reservoir development area by regulations made under *The Water Resources Management Act, 1972* (now known as the Saskatchewan Watershed Authority Act, 2005); or
- ❑ that is within 457 m (1500 ft) from the high water mark level of a lake, river, stream or other body of water and upon which is situated an urban municipality or, a summer resort or, is established as a recreation area.

A minimum parcel size of 465 m² (5000 ft²) is required for mound systems. These systems must be at least 150 m (500 ft) from the high water level of a lake, river, stream or other body of water located within a shoreland development area. In addition there should be an isolation distance of 7.6 m (25 ft) in sandy soils and 1.5 m (5 ft) in clay soils between the system and ground water. For various other disposal methods, the minimum isolation distances from the high water level are as follows:

- | | |
|--|---|
| ❑ holding tanks/septic tanks/ privy vaults | 15 m (50 ft) horizontal
3 m (10 ft) vertical |
| ❑ privy pit | 30 m (100 ft) |
| ❑ grey water seepage pit | 30 m (100 ft)
15 m (50 ft) horizontal |

Other Regulations/Bylaws

Permits granted under *The Plumbing and Drainage Regulations* only provide lawful authority to establish, construct, extend, renovate, alter or repair a private sewage works, as the case may be, pursuant to *The Plumbing and Drainage Regulations*. The permit does not displace or override other legislative requirements or restrictions, which may exist pursuant to applicable federal or provincial legislation, or municipal bylaw. For example, municipal bylaws may be more restrictive than provincial laws. Installers of private sewage works should check with the local municipality to determine if any such bylaw is in effect.

4.1 DESCRIPTION OF SENSITIVE AREAS

The overall goal of this manual is to protect the environment and human health. This section describes the sewage disposal restrictions and options that apply to various location types. Both the density of the development and the characteristics of the proposed location, affect the permit requirements, site investigations, and allowable onsite systems.

Private sewage works regulations and guidelines are intended to minimize the impact of sewage effluent on water supplies, communities and neighbours. In areas far removed from communities, water supplies and neighbours, the risk of contamination or nuisance creation is low. These are considered low sensitivity areas and sewage disposal requirements are less rigorous than they are in more sensitive areas. It should be noted that sewage holding tanks are acceptable in any area and may be installed by non-certified contractors. In areas where *The Shoreland Pollution Control Regulations, 1976* apply or where municipal bylaws are in effect, the following guidance does not apply.

The local health region should be consulted for further clarification if there is uncertainty about a proposed private sewage works in a specific area. If the private sewage works serves a non-residential facility or other facility with a very large sewage design volume or composition that varies from those produced by an average dwelling (greater than 300 mg/L BOD, 350 mg/L TSS or 25 mg/L grease content), it may be subject to further restrictions. Some commercial/industrial systems may require qualified environmental engineering design as the system design information contained in this guideline is generally based on residential dwelling situations.

After determining the location characteristics and density of the area, each applicant may be obliged to meet the requirements in Table 1. It should be noted that the requirements in Table 1 are a minimum and the designer and owner of the proposed system should consider the treatment capabilities of any proposed system alternatives. For example, gravity systems may be adequate for some locations however, pressure systems perform a higher degree of treatment for organic matter, microbes and most cations.

The proponent of the private sewage works must submit plans to the local health region for approval.

4.1.1 Location

Each application for a private sewage works is determined to be in one of the following two locations.

Adequate Location

An adequate location is all those locations that are not considered sensitive.

Sensitive Location

In determining whether an area is a sensitive location, the Health Region should consider the following items:

1. If the subdivision, in which the parcel/lot is contained, is less than 1.0 km (0.6 miles) to the boundary of any municipality (city, town, village, organized hamlet, park subdivision or approved subdivision containing at least 2 parcels/lots) that utilizes groundwater source(s) for drinking water purposes.
2. The presence of coarse soils over an unconfined aquifer, that is of sufficient quality and quantity to be used as a drinking water source. The presence of high levels of aesthetic constituents should not be used to determine drinking water suitability.
3. The presence of subsurface water (seasonal or permanent), which is less than 1.5 meters (5 ft) below natural ground surface elevation.
4. Historical concerns with well water quality (in particular nitrate) believed to be due to human activities.

4.1.2 Density

The density of the surrounding development should be determined by the Health Region for each application for a private sewage works. Though the discussion below mentions a ¼ section, this can be viewed as any continuous area ½ mile (800 m) by ½ mile (800 m). Based on discussions with the Municipality regarding zoning bylaws and municipal development plans, the density of an area may be determined by final development plans for the immediate surrounding the proposed system. The average land size is determined by using the sizes of those lots subdivided from the existing piece of land.

Low Density Area

All subdivision are considered low density where:

1. Less than 5 existing or proposed residential units are located on a ¼ section; **or**
2. The average land size associated with each existing or potential residential unit is greater than or equal to 4 hectares (10 acres), with no portion of land being smaller than 1 hectare (2.5 acres).

If a subdivision is not a low density development then compare its characteristics to the high density definition.

High Density Area

All subdivisions that are not low density are considered high density where:

1. 40 existing or proposed residential units or more on a ¼ section; **or**,
2. The average land size associated with each existing or potential residential units is less than 1 Ha (2.5 acres).

Medium Density Area

If a development is neither a low density development nor a high density development, it is considered a medium density area. In general, a medium density subdivision is characterized by between 5 and 39 existing or potential residential units and/or smaller lot sizes.

Table 1 - MATRIX OF SEWAGE SYSTEM PERMIT REQUIREMENTS

		Location	
		Adequate	Sensitive
Density	Low <5 residential units on ¼ section; or land sizes ≥ 4 Hectares (10 acres) with no lot < 1 Hectares (2.5 acres) on ¼ section.	Site Investigation Basic Investigation ¹ Acceptable Systems ^{2,3} Holding tanks, Absorption/chamber systems, Type I and II mounds, Lagoons (≥4 Ha only), Package treatment plants with Disposal	Site Investigation Detailed Investigation Acceptable Systems ² Holding tanks, Pressure absorption/pressure chamber systems, Type II mounds, Lagoons (≥4 Ha only), Package treatment plants with Disposal
	Medium All developments not considered to be high density or low density. (Generally, those locations with between 5 and 39 residential units and average lot sizes	Site Investigation Basic Investigation Acceptable Systems ² Holding tanks, Absorption/chamber systems, Type I and II mounds, Lagoons (≥4 Ha only), Package treatment plants with Disposal	Site Investigation Detailed Investigation Acceptable Systems ² Holding tanks, Pressure absorption/pressure chamber systems, Type II mounds, Lagoons (≥4 Ha only), Package treatment plants with Disposal
	High 40 or more residential units on a ¼ section; or land size is < 1 Ha (2.5 acres) on ¼ section	Site Investigation Detailed Investigation Acceptable Systems ² Holding tanks, Pressure absorption/pressure chamber systems, Type II mounds, Lagoons (≥4 Ha only), Package treatment plants with Disposal	Site Investigation Detailed Investigation Acceptable Systems ² As determined ⁴

1 Sufficient information needs to be collected to for proper siting and design. In the case of a jet system, a detailed site plan is the minimum requirement rather than the Basic Investigation. In all other cases, a basic site investigation may be acceptable to the Health Region.

2 Holding tanks are acceptable in all situations and do not require a site investigation.

3 Jets are also permitted in these areas if the land size is greater than 4 Ha (10 acres) and there is no other municipality⁵ within 1 km.

4 Acceptable private sewage works required for high density developments in sensitive locations are determined from the detailed assessment completed at the time of the subdivision approval. If no assessment is available, the Health Region may permit systems such as holding tanks, pressure absorption, pressure chamber systems, type II mounds, lagoons (≥4 Ha only), and package treatment plants with disposal. However, the Health Region should be consulted to determine appropriate systems.

5 A municipality includes any city, town, village, organized hamlet, park subdivision or approved subdivision containing at least 2 parcels/lots.

4.2 SITE INVESTIGATIONS

Site investigations occur as part of each individual application for a sewage disposal permit. In cases where holding tanks are utilized, a site investigation is not required.

4.2.1 Basic Site Investigation

Private sewage works proponents need to consider whether the soils at this location would be suitable to sufficiently renovate effluent. Applications for Sewage Disposal Permits are to be made through the local Health Region Office and should be accompanied by design specifics, and location details.

Design specifics for each site should include:

- Information on general site and soil conditions of the disposal field (unless the system proposed is a jet system);
- Soil texture classification to a depth of at least 0.9 metres (3 feet) (eg. the depth of the infiltration surface) and;
- If necessary or used for confirmation, results of percolation tests in minutes per 2.5 cm. Sites where soils testing indicate unsuitable soils can complete percolation testing to size the system;
- The estimated daily design flow of wastewater generated by the facility being served as per the Saskatchewan Onsite Wastewater Disposal Guide;
- Mass loading should be considered where effluent does not meet residential sewage standards, such as restaurant food preparation waste; and
- The type of proposed system, the land area required and, if present, existing system(s).

A site drawing of each lot should be submitted and include:

- Lot boundaries, property size, and dimensions;
- Locations of springs, dugouts or wells accessing an unconfined aquifer providing water for domestic purposes within 150 m of the proposed system;
- Locations and size of private sewage works, any existing systems, and any reserve areas on the lot/subdivision;
- Locations of any test pits, bore holes or percolation tests;
- Location of all proposed or existing septic tanks, services, sewage break-outs locations, drains, trees and building structures;
- Set back distances from proposed or existing systems to all existing or proposed pertinent features such as wells, buildings, right of ways, etc.;
- Surface slopes and drainage characteristics; and
- Location of any unsuitable (eg. Large fills, steeply sloping areas, etc), disturbed or compacted areas.

4.2.2 Detailed Site Investigation

Private sewage works proponents need to consider whether the soils at this location would be suitable to sufficiently renovate effluent. Applications for Sewage Disposal Permits are to be made through the local Health Region office and should be accompanied by design specifics, and location details.

Design specifics for each site should include:

- The estimated daily design flow of wastewater generated by the facility being served;
- Mass loading should be considered where effluent does not meet residential sewage standards, such as restaurant food preparation waste;
- Results of a soils investigation (A minimum of one representative location requires testing.);
- A description of the soil profile, including the soil horizons, texture, structure, consistence, colour, in particular at the depth of the proposed infiltrative surface;
- A description of key features and their measured depths, including soil redoximorphic features (gleyed or mottled soil), roots, total depth of each test pit and presence of any water;
- Particle sizing of soils within a test pit, or bore hole methodology. Soil samples are to be collected at 0.91 meters (3 feet), 1.5 metres (5 feet) and 2.8 meters (8 feet) for particle sizing. (See appendix for information on test pits);
- The depth of the flow restricting horizon(s), water table, expected seasonal high water table, and other soil moisture conditions;
- Soil permeability:
 - For soil testing, the test result selected should be from the depth of the infiltration surface unless a deeper value is significantly more restrictive. Soil testing is required; and
 - Where the percolation test is used for confirmation, the results of the percolation tests should be submitted. Percolation tests may be conducted but are not required; and
- The type of proposed system, the land area required and, if present, existing system(s).

A site drawing of each lot should be submitted and include:

- Lot boundaries, property size, and dimensions;
- Locations of springs, dugouts or wells accessing an unconfined aquifer providing water for domestic purposes within 800 m of the proposed system;
- Locations and size of private sewage works, any existing systems, and any reserve areas on the lot/subdivision;
- Locations of any test pits, bore holes or percolation tests;
- Location of all proposed or existing septic tanks, services, break-outs/drains, trees and building structures;
- Set back distances from proposed or existing systems to all existing or proposed pertinent features such as wells, buildings, right of ways, etc;
- Description of site topography – including slope, slope type and slope location for the proposed disposal area; and

- Location of any unsuitable (eg. Large fills, steeply sloping areas, etc), disturbed or compacted areas.

The application should also include information on:

- Any stormwater management plan present on the lot or in the subdivision; and
- Any soil characteristics that limit the selection of and the long-term suitability of a private sewage works.

Every lot, where a private sewage works is proposed, should be examined separately to determine the proper design and installation of the system. The boundaries of the lot should be clearly and accurately flagged with survey tape. Lot numbers or letters should also be marked on site.

Sites with marginal soils or other challenging conditions should consider linear loading, groundwater mounding issues and locations of possible replacement areas. If an assessment was completed during the subdivision approval process, these marginal areas may have been previously generally identified. Sites where soils testing indicate unsuitable soils can complete percolation testing to size the system or utilize Table A.15 found in Appendix 15.

The outcomes of the detailed site investigation is to assist the installer in determining the ability of the proposed system to be sited on the property, maintain proper setback distances, and to operate as designed.

4.3 PERMISSIBLE SOLUTIONS

Permissible solutions are listed in the Matrix of Permit Requirements. Unless otherwise approved by the local authority, only the listed systems should be constructed on sites in a particular density and location. In the case of sensitive locations and high density developments, the assessment completed at the time of subdivision approval should determine the types of systems permissible. If an assessment is not available, the Health Region may permit systems such as holding tanks, pressure absorption/ chamber systems, type II mounds, lagoons (≥ 4 Ha only), and package treatment plants with disposal. In every situation, the proponent of the private sewage works must submit plans to the local health region for approval.

5.1 DEFINITION

A holding tank is a one-compartment tank designed to collect and hold sewage without treatment prior to its being transported to a final point of disposal.

5.2 FUNCTION

A holding tank is a storage receptacle for sewage and wastewater until it can be transported to a final point of disposal. It does not provide any physical or biological process for its contents. For this reason, holding tanks are primarily used on developed properties where no other alternative methods of wastewater disposal are feasible. Properties that do not have an adequate area for wastewater treatment system, properties located along a lakeshore or properties with unusual circumstances may need to utilize a holding tank. Proposals for the installation of holding tanks are reviewed on the basis of public health requirements and municipal law and the proponent may be asked to indicate why other methods of wastewater treatment are not feasible.

5.3 DESIGN

Holding tanks must provide safe and adequate temporary storage of sewage, with scheduled and approved pumping service and disposal of the stored sewage. The design, installation and operation of holding tanks must ensure that ground or surface waters are not contaminated, the public is not exposed to untreated sewage or source of nuisance odors is not created.

Figure 5.1 Concrete Holding Tank

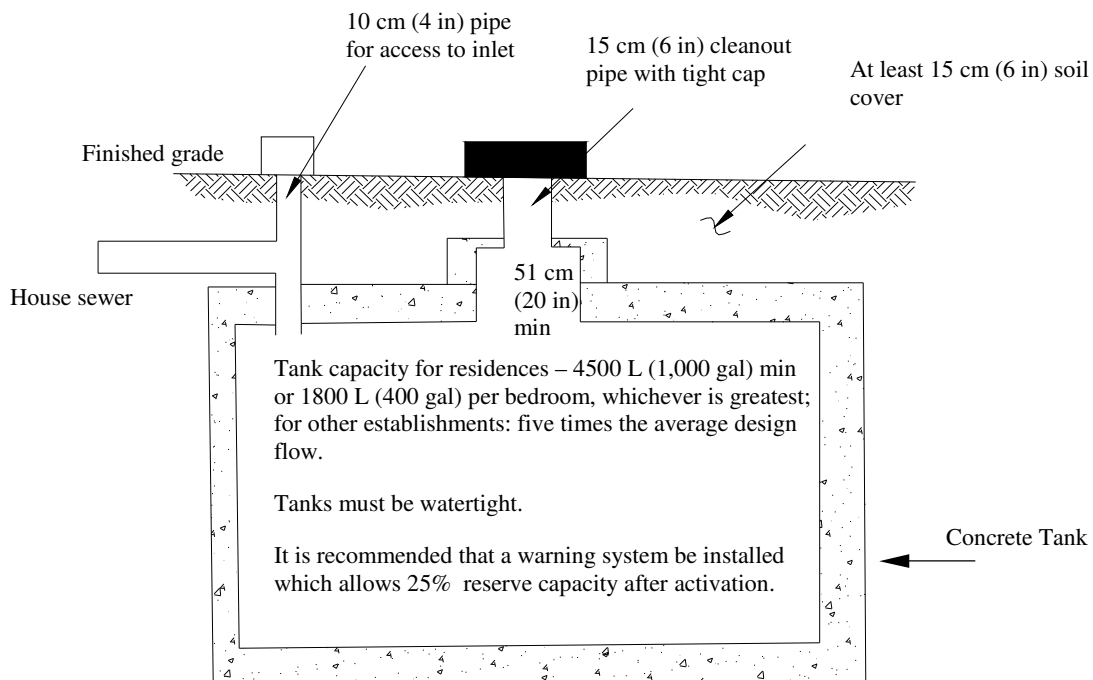

5.3.1 Capacity

Capacity is one of the most important considerations in holding tank design. Liberal tank capacity is important from an economic perspective. Large holding tanks minimize the frequency of tank pumping. *The Plumbing and Drainage Regulations* state that holding tanks shall have a capacity of at least 4546 L (1000 gals). As a rule, single family dwellings should have a holding tank that is about 1800 L (400 gals) times the number of bedrooms. For other establishments, the capacity should be based on measured flow rates or estimated flow rates. The tank capacity should be at least five times the average daily flow rate.

5.3.2 Tank Construction

In all shoreland development areas, urban centres and subdivisions, prefabricated sewage holding tanks must conform to the most current CSA standard for prefabricated septic tanks and holding tanks, except that an inlet baffle must not be an elbow fitting. Holding tanks must be watertight and constructed of sound and durable materials that are not subjected to excessive corrosion, frost damage, cracking or buckling due to settlement or back filling.

Figure 5.2

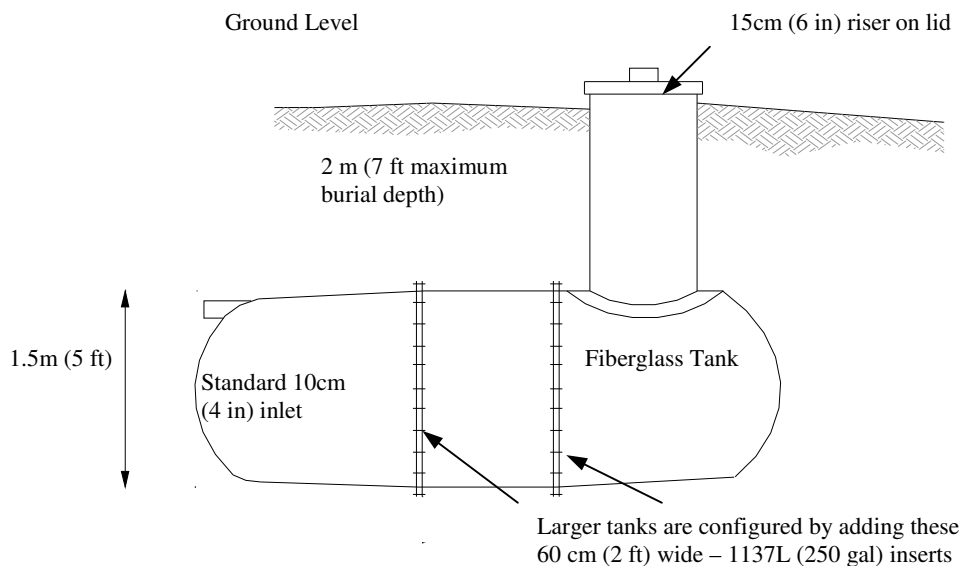

5.3.3 Tank Access

An access opening at least 50 cm (20 in) in diameter is necessary for servicing. In order to be accessed quickly, it should be above the final grade and must be secured to prevent the casual observer or a child from attempting to get into the tank. A cover weighing at least 30 kg (65 lbs) may be considered as secure. Access openings terminating below the ground surface should do so no closer than 15 cm (6 in) below finished grade. In this case, a cleanout pipe of at least 15 cm (6 in) in diameter shall extend to the ground surface and be provided with seals to prevent odour and to exclude insects and vermin.

5.3.4 Water Tightness

A holding tank must be a watertight tank. Water entering from surface runoff or groundwater will reduce the available storage capacity for wastewater. Wastewater leaking from the tank can threaten groundwater quality. Tongue and groove joints and cleaning access extensions should be joined using a waterproof mastic compound.

5.4 INSTALLATION

Important installation considerations include tank location, bedding and backfilling, watertightness and floatation prevention, especially with non-concrete holding tanks. The maximum burial depth of all tanks is specified by the manufacturer and should never be exceeded. Roof drains, surface water runoff, and other clear water sources must not be routed to the holding tank.

Before installing a holding tank, a permit is required. Applications for permits should be made through the local health region and shall be accompanied by design specifics, and location details.

Backfilling should be completed with suitable fill that is free of sharp rocks or large earth blocks.

5.4.1 Site Selection

Holding tanks should be located where they cannot cause contamination of any well, spring or other source of water supply.

Unless otherwise permitted by *The Plumbing and Drainage Regulations*, all holding tanks conforming to CSA standards should be:

- ❑ accessed easily for sewage removal.
- ❑ installed in accordance with instructions provided by manufacturer.
- ❑ installed in a bed that is free of sharp rocks or large earth blocks that could damage the tank.
- ❑ installed in a fashion that will ensure that the holding tank, building sewer connection and access openings are watertight.

It is not a good installation practice to bury tanks in areas where a high water table exists as this increases the stress load on the tank (the deeper the burial in water and or saturated soil, the more stress). However, it is recognized that, in some situations, burial in the water table is necessary. In such cases, the contractor should:

- (1) advise the cottage/homeowner of the stress/pressure implications;
- (2) ensure that the water table does not rise above any openings to the tank; and
- (3) anchor the tank per manufacturer's instructions to prevent floatation and/or shifting.

Holding tanks should not be installed in flood plains, drainage ways or depressions unless flood protection is provided. It is also recommended that plastic piping within 1800 mm (6 feet) of a holding tank not be lighter than D.W.V.

Section 6.4.2 "Excavations for Septic Tanks" should be considered when installing a holding tank.

5.4.2 Setback Requirements

When locating a holding tank the minimum setback distance shall be:

<input type="checkbox"/> Basement	1 m (3 ft)
<input type="checkbox"/> Large tree	3 m (10 ft)
<input type="checkbox"/> Property Boundary	3 m (10 ft)
<input type="checkbox"/> Walk/Driveway	1.5 m (5 ft)
<input type="checkbox"/> Cut or embankment	3 m (10 ft)
<input type="checkbox"/> Well	9 m (30 ft)
<input type="checkbox"/> Water Course	9 m (30 ft)

The holding tank should be located so as not to impact on the water table. If a contractor is in doubt as to what would be considered an appropriate separation, they are strongly urged to contact the local health region before installation.

Where a building has no basement walls, a holding tank may be installed beneath the floor of such a building provided that access to the tank for inspection and pumping purposes is from the exterior of the building and no unsealed access port is present in the building or beneath the building. The tank shall be properly vented to ensure fumes do not enter the building. A basement wall shall not be used as a wall of a holding tank.

5.4.3 Inspection

Before the tank is covered, the local health region shall be contacted to request an inspection. A Public Health Inspector with the local health region may inspect the tank installation or provide approval to proceed with backfilling.

5.5 CARE AND MAINTENANCE

The holding tank typically requires little operator intervention. Regular inspections and sewage pumping are the only operation and maintenance requirements. To assure that this work can be performed efficiently, the system must be designed, installed, and maintained in a way which promotes ease of access for pumping and cleanup.

Large tanks greater than 9,000 L (2,000 gals) should have multiple access points (pumping access ports) to allow for efficient pumping of all contents.

6.1 DEFINITION

A septic tank is a two-compartment tank of which the first compartment is a settling tank and the second compartment is a storage compartment for the effluent from the first compartment.

6.2 FUNCTION

Everything that goes down any of the drains in the house (toilets, showers, sinks, laundry machines, etc.) travels first to the septic tank. It is a watertight receptacle designed, constructed and installed to receive sewage and wastewater. The septic tank provides a complex interaction of physical and biological processes. The essential functions of the septic tanks are to provide:

- removal of solids;
- biological treatment; and
- sludge and scum storage.

In this manner the turbidity of the effluent is significantly reduced so that it may be more readily percolated into the subsoil of the ground. Thus the most important function of a septic tank is to provide protection for absorption ability of the subsoil.

6.2.1 Removal Of Solids

Organic and inorganic solids are removed by the physical process of sedimentation and floatation. As sewage from a building sewer enters a septic tank, its rate of flow is reduced so that many particles sink to the bottom or rise to the surface. The reduction in flow allows material that is denser than water to settle out and material less dense than water to float to the surface. This will allow for approximately 40 to 80 percent of suspended solids to be removed from the waste stream [30-50% Biological Oxygen Demand (BOD) reduction].

There are several factors that will affect this process of settling rate. Water is denser at lower temperatures; therefore, the required settling time increases. As the temperature of the water increases, the required settling time decreases. Often the effluent temperature varies between 8°C and 28°C (46°F and 82°F).

Another factor that is critical is the equal distribution of the flow throughout the tank. A greater the velocity in one area will result in less actual detention time. Solids not having sufficient time to settle out will be discharged in the effluent.

6.2.2 Biological Treatment

Solids and liquid in the tanks are subjected to decomposition by bacterial and natural processes. The bacteria present are a variety known as anaerobic which thrive in the absence of free oxygen. The decomposition or treatment of sewage under anaerobic conditions is termed “septic”, hence the name of the tanks.

The solids retained in the tank undergo anaerobic decomposition resulting in the formation of gas. The gases entrained in the solids cause them to rise through the wastewater to the surface and lie as a scum layer until the gas has escaped, after which the solids settle again. This biological process is able to considerably reduce the volume of sludge. This allows the septic tank to operate for periods of one to four years or more, depending on site circumstances, before it needs to be cleaned.

6.2.3 Sludge And Scum Storage

Sludge is an accumulation of solids at the bottom of the tank, while scum is partially submerged mat of floating solids that may form at the surface of the fluid in the tank. Sludge, and scum to a lesser degree, will be digested and compacted into a smaller volume. However, no matter how efficient the process is, the residual or inert solid material will remain. Space must be provided in the tank to store this residue during the interval between cleanings; otherwise, sludge and scum will eventually be scoured from the tank and may clog the disposal field.

6.3 DESIGN

The design of the septic tank should promote and facilitate the separation and digestion of the sewage solids and provide the periodic inspection and occasional physical removal of accumulated sludge and scum.

6.3.1 Capacity

Capacity is one of the most important considerations in septic tank design. Liberal tank capacity is not only important from a functional standpoint, but is also good economy. It is important that the capacity be ample to permit reasonably long periods of trouble-free service and to prevent frequent and progressive damage to the infiltrative soil surface due to discharge of suspended solids. References to septic tank sizing in this guide refer to “working capacity”. This is the working (first) compartment of the septic tank in which the liquid volume of sewage that will remain in the septic chamber, but does not include the air space, siphon chamber, pumping chamber or effluent chamber. Caution must be exercised when sizing a septic tank as the manufacturer’s model number does not necessarily indicate the “Working Capacity” of their product.

Number of Bedrooms	Daily Sewage Flows	Minimum Working Compartment Size	Working Compartment Size for Pressure Distribution
2	1360 L 300 gals	1360 L 450 gals	2730 L 600 gals
3	1530 L 337 gals	2300 L 500 gals	2730 L 600 gals
4	2040 L 450 gals	3070 L 675 gals	3070 L 675 gals
5	2550 L 562 gals	3840 L 845 gals	3840 L 845 gals
6	3060 L 675 gals	4600 L 1010 gals	4600 L 1010 gals

To accommodate waste from garbage disposal units, septic tanks should have their working capacity increased by 50% or the tank should be cleaned more often to remove the sludge that accumulates at a faster rate.

In the case of commercial/industrial facilities, it may be necessary to secure the advice of an experienced engineer who will determine probable daily water usage and sewage flow. Most recent information indicates that for flows between 2000 L (440 gals) and 6000 L (1320 gals) per day, the capacity of the working compartment of the septic tank should be equal to at least 1½ days' sewage flow.

In either case, advice should be obtained from your local health region.

6.3.2 Tank Construction

Septic tanks must be watertight and constructed of sound and durable materials that are not subjected to excessive corrosion, frost damage, cracking or buckling due to settlement or backfilling. Common materials include concrete and fiberglass. In all shoreland development areas, urban centres and subdivisions, prefabricated sewage holding tanks must conform to the most current CSA standard for prefabricated septic tanks and holding tanks, except that an inlet baffle must not be an elbow fitting.

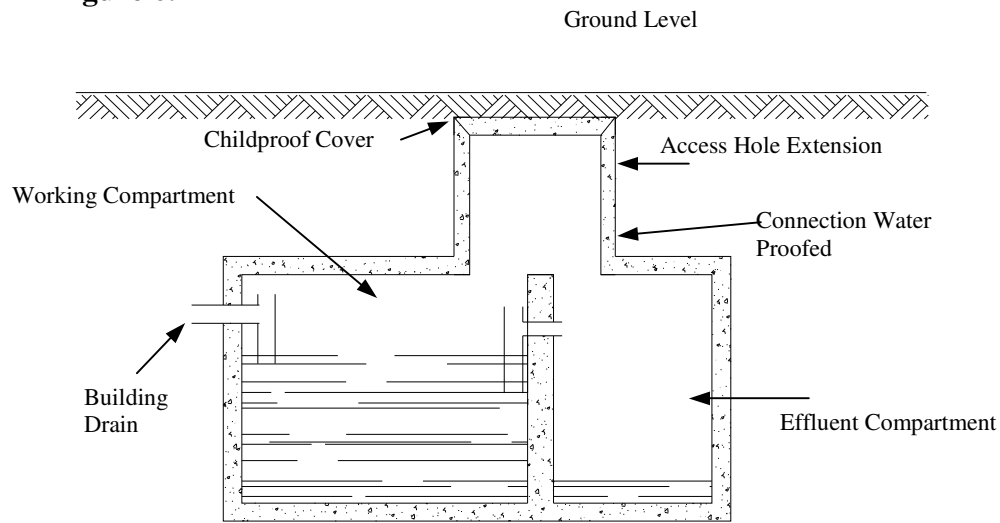
Figure 6.1

The following are requirements intended to act as a guide for constructing a “*poured in place*” septic tank in locations where *The Plumbing and Drainage Regulations* permit their use. The requirements are not intended to supersede any design criteria that is specified in the most current CSA standard for prefabricated septic tanks and holding tanks:

- ❑ The working (first) compartment should have a liquid depth, measured at the deepest point of not less than 1.2 m (4 ft). This distance may be altered to accommodate tanks of special design such as those installations being placed in high water table areas.
- ❑ There should be a minimum of 300 mm (12 in) air space between the maximum sewage level and the highest point of the ceiling of the septic tank body. The volume of the air space provided should not be less than 10 percent of the working capacity of the septic tank.
- ❑ The inlet to the septic chamber should be provided with a flow diversion (a baffle or TY) device extending not less than 75 mm (3 in) into the sewage.
- ❑ The outlet of the septic chamber should also have a TY fitting or baffle extending 450 – 650 mm (18-25 in) into the sewage. The top of such a fitting or baffle should not be more than 50 mm (2 in) below the ceiling of the tank body.
- ❑ Outlets should be protected by a device which deflects gas and particles away from the outlet. The invert of the outlets should not be less than 50 mm (2 in) below the invert of the inlet.
- ❑ The distance between the inlet and the outlet of the working (first) compartment should not be less than 1.2 m (4 ft) measured horizontally. This distance is measured from the vertical centre line of the inlet and outlet fittings or if baffles are provided, from a point midway between the baffle and adjacent tank wall.

- ❑ Extensions for access openings should be constructed of sound durable material of a standard not less than that required for the septic tank construction and should have a minimum diameter of 600 mm (24 in). The connection between the septic tank and extension should be waterproofed and the extension extended to grade. Extension covers should be childproof.
- ❑ Septic tanks should not be buried deeper than the depth of burial recommended by the manufacturer. The excavation necessary for a septic tank may be reduced if advantage is taken of natural ground surface grade.
- ❑ Septic tank inside dimensions should not be less than 1.7 m (5.5 ft) long, 0.9 m (3 ft) wide and have a minimum liquid depth of 1.2 m (4 ft) unless otherwise approved.
- ❑ For those systems which do not rely on gravity to discharge the liquid effluent, the installation of an effluent pump will be necessary. These pumps are normally activated by a liquid level control in the effluent (second) compartment of the septic tank. Common control types are: electrodes, floats and pneumatic. These controls require 2 - 3 annual service checks to ensure their successful operation.
- ❑ Appendix 21 – Dosing should be considered when developing a private sewage works.

6.3.3 Inlets And Outlets

The inlet baffle is designed to dissipate the energy of the effluent flow and deflecting it downward into the tank. The rising inlet of the tee should extend at least 150 mm (6 in) above the liquid level to prevent the scum layer from plugging the inlet. It should be open at the top to allow venting of the tank through the building sewer and out the plumbing stack vent. The descending leg should extend well into the clear space between the sludge and scum layers, but not more than 30 to 40 percent of liquid depth.

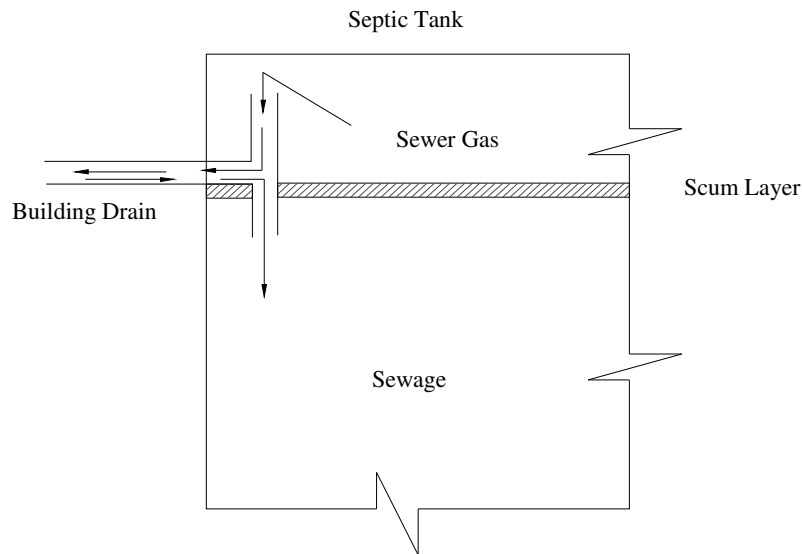
Figure 6.2

The outlet baffle, between the working compartment and the effluent compartment, is designed to draw wastewater from the clear zone between the sludge and scum layers. It allows the wastewater to overflow into the effluent compartment or pump chamber.

6.3.4 Tank Access

An access opening of 60 cm (24 in) in diameter is necessary for pumping septage, observing the inlet and outlet baffles, and for servicing. In order to be accessed quickly, it should be above the final grade and must be secured to prevent the casual observer from attempting to get into the tank. A cover of at least 30 kg (65 lbs) may be considered as secure.

6.3.5 Water Tightness

A septic tank must be a watertight tank. This is critical to the performance of the entire onsite wastewater system. Water entering the septic tank from surface runoff or groundwater adds to the hydraulic load of the system and can upset the subsequent treatment process. Wastewater leaking from the tank can threaten groundwater quality and low wastewater levels in the tank can disturb the treatment process.

Tongue and groove joints and cleaning access extensions should be joined using a waterproof mastic compound.

6.3.6 Compartmentalized Tanks

For larger systems, where septic tank capacities greater than 13,000 L (2900 gals) are proposed, it may be necessary to connect several holding tanks in a series. The following recommendations apply to compartmentalized tank systems:

- the first compartment should contain one half the total volume
- the connection between compartments must be baffled
- there must be adequate access to each compartment
- a maximum of four tanks may be installed in a series

6.3.7 Special Considerations

Special considerations should be made when designing a septic tank for other than a private residence.

Restaurants – Restaurant waste typically contains large amounts of cooking fats and greases, many of which have been removed from the cooking utensils by the use of degreasers. For the grease to again coagulate and separate from the liquid, both dilution and cooling must take place.

High temperature dishwashers, which have internal heaters, may discharge wastewater with temperatures as high as 60°C (140°F). Tanks that are in series, and thus contact with more soil, provide better cooling.

Laundromats – Laundromats have the problem of excessive washing products (detergent) use, along with the lint that is typically discharged with the wash water. In some cases, lint traps have been used effectively to reduce the amount discharged into the septic tank system. Very little sludge accumulates in the septic tanks of a laundromat system. However, large volumes of wastewater 1800 L (400 gals) per day per machine can be expected.

Slaughterhouses – Because blood has an extremely high oxygen demand, it is very difficult to break down in a septic system. When slaughterhouses have their own private sewage works, no blood should be allowed to enter the septic tank. There may be small amounts of blood entering with the cleanup water but the major amounts should be collected and disposed of separately from the sewage system.

Milk House Waste – Experience has shown that milk solids do not break down under anaerobic digestion present in a septic tank. Consequently, subsurface disposal fields should not be used with milk wastes.

6.4 INSTALLATION

Important construction considerations include tank location, bedding and back filling, water tightness and floatation prevention, especially with non-concrete tanks. Roof drains, surface water runoff, and other clear water sources must not be routed to the septic tank. Attention to these considerations will help to ensure that the tank performs as intended.

Manufacturers' instructions should be followed for the installation of septic tanks.

It is recommended that plastic piping within 1800 mm (6 feet) of a septic tank not be lighter than D.W.V. The connection between the pipe and the tank should be accomplished with a watertight, resilient and preferable, flexible connector, such as a boot. Alternatively, the pipe can be grouted in the field. Proper pipe and tank bedding is very important to ensure that shearing of the pipe at the tank inlet, outlet or at the foundation does not occur.

6.4.1 Site Selection

Septic tanks should be located where they cannot cause contamination of any well, spring or other source of water supply. Underground contamination may travel in any direction and for considerable distances under saturated conditions. It is therefore necessary to rely on horizontal as well as vertical distances for protection.

Septic tanks should not be installed in flood plains, drainage ways or depressions unless flood protection is provided. Also, it is important to consider the proximity to the largest possible area available for the disposal field.

Unless otherwise permitted by *The Plumbing and Drainage Regulations*, all septic tanks conforming to CSA standards should be:

- ❑ accessed easily for sewage removal;
- ❑ installed in accordance with instructions provided by manufacturer;
- ❑ installed in a bed that is free of sharp rocks or large earth blocks that could damage the tank; and
- ❑ installed in a fashion that will ensure that the septic tank, building sewer connection and access openings are watertight.

It is not a good installation practice to bury tanks in areas where a high water table exists as this increases the stress load on the tank (the deeper the burial in water and or saturated soil, the more stress). However, it is recognized that, in some situations, burial in the water table is necessary. In such cases, the contractor should:

- (1) advise the cottage/homeowner of the stress/pressure implications;
- (2) ensure that the water table does not arise above any openings to the tank; and
- (3) anchor the tank per manufacturer's instructions to prevent floatation and/or shifting.

6.4.2 Excavations for Septic Tanks

It is important that excavations for septic tank (and holding tanks) are completed properly. The diagram on the left of Figure 6.3 demonstrates an improperly supported tank. The right side of Figure 6.3 shows the resulting condition. An improperly supported septic tank will settle and may cause breakage or disconnection of the inlet and outlet piping from the tank.

Figure 6.3

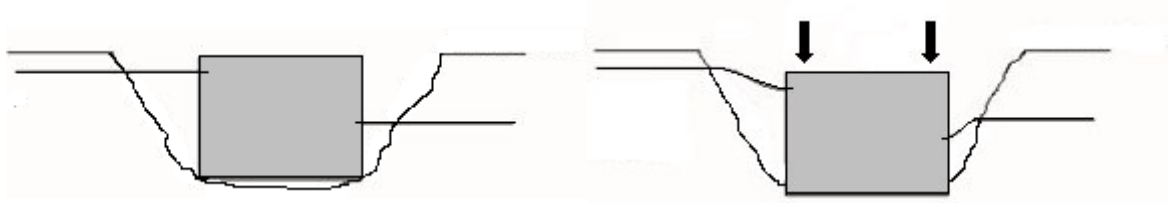

Figure 6.4 shows the result of an excessive excavation. In this situation, the long sloping ends of an excavation do not provide support for the inlet and outlet piping connected to the septic tank. The weight of the soil above the unsupported piping may cause the breakage of the piping.

Figure 6.4

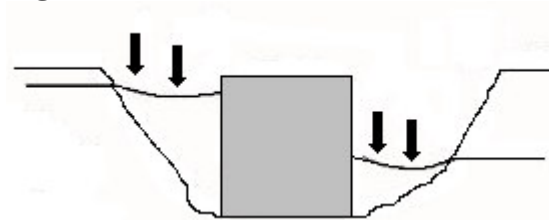
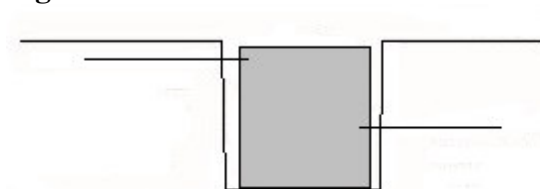

Figure 6.5 shows a proper excavation for a septic tank. There will be steep vertical ends to provide proper support for the inlet and outlet piping as close to the tank as possible and will have a flat undisturbed or compacted base.

Figure 6.5



The excavation beneath a septic tank should be flat native material. A compacted bedding material of at least 100 mm (4 in) of a sand/gravel mixture is recommended, in particular, if over-excavation has occurred. Each lift should be 100 to 150 mm (4-6 in) and should be lightly compacted before the placement of the next lift. Please note that the use of crushed rock may damage some types of tanks and should not be used if this is a concern. The installer should take care that the tank remains undamaged and that the manufacturer's instructions for back filling, which may include the use of pea gravel, are followed.

Backfilling should be completed with a suitable fill that is free of sharp rocks or large earth blocks. When backfilling around the tank, lifts of 300 mm (12 in) or less should be placed around all sides of the tank. Each lift should be lightly compacted before placement of the next lift. The soil should be mounded on top of the tank to direct water away from the tank lid.

6.4.3 Setback Requirements

When locating a septic tank, the minimum setback distance shall be:

<input type="checkbox"/> Basement	1 m (3 ft)
<input type="checkbox"/> Cistern	3 m (10 ft)
<input type="checkbox"/> Large tree	3 m (10 ft)
<input type="checkbox"/> Property Boundary	3 m (10 ft)
<input type="checkbox"/> Walk/Driveway	1.5 m (5 ft)
<input type="checkbox"/> Cut or embankment	3 m (10 ft)
<input type="checkbox"/> Well	9 m (30 ft)
<input type="checkbox"/> Water Course	9 m (30 ft)

The septic tank should be located so as not to impact on the water table. If a contractor is in doubt as to what would be considered an appropriate separation, they are strongly urged to contact the local health region before installation.

Where a building has no basement walls, a septic tank may be installed beneath the floor of such a building provided that access to the tank for inspection and pumping purposes is from the exterior of the building and no unsealed access port is present in the building or beneath the building. The tank shall be properly vented to ensure fumes do not enter the building. A basement wall shall not be used as a wall of a septic tank.

6.4.4 Inspection

Before the tank is covered, the local health region shall be contacted to request an inspection. A Public Health Inspector with the local health region may inspect the tank installation or provide approval to proceed with back filling.

6.5 CARE AND MAINTENANCE

The septic tank typically requires little operator intervention. Regular inspections and septage (sludge) pumping are the only operation and maintenance requirements.

Please see Appendix 16, for more information on the care and maintenance of septic tanks.

7.1 DEFINITION

A chamber system is a wastewater treatment system consisting of trenches or beds, together with one or more distribution pipes or open-bottomed plastic chambers, installed in appropriate soils. These chambers receive wastewater flow from a septic tank or other treatment device and transmit it into the soil for final treatment and disposal.

7.2 FUNCTION

Chamber systems have two key functions: to dispose of effluent from the septic tanks and to distribute this effluent in a manner allowing adequate natural wastewater treatment in the soil before the effluent reaches the underlying groundwater aquifer.

Chamber systems are installed in trenches and connected to the septic tank via pipe. Effluent flows out of the septic tank and is distributed into the soil through the chamber system. Chamber systems allow more of the soil profile to be used since the septic tank effluent is distributed to the ground below and the soil surrounding the chamber. Therefore, chambers are more effective than traditional gravel drain fields. The soil below the drainfield provides final treatment and disposal of the septic tank effluent. After the effluent has passed into the soil, most of it percolates downward and outward, eventually entering the shallow groundwater. A small portion of the effluent is used by plants through their roots or evaporates from the soil. Although the septic tank removes some pollutants from wastewater, further treatment is required after the effluent leaves the tank. Suspended solids, organic and inorganic materials, and bacteria and viruses must be reduced before the effluent is considered purified. These pollutants are reduced or completely removed from the wastewater by the soil into which the wastewater drains from the leaching chambers.

7.3 DESIGN

Preformed chambers must be constructed of a material that will not deteriorate over time. The chambers must meet the American Association of State Highway and Transportation Officials (AASHTO) load rating of H-10.

All piping used in or in conjunction with the system must be of a type that is acceptable to the local health region.

The size of a chamber system is based on the wastewater flow and soil properties. For a three bedroom home, the area needed for a chamber system could range from 18.6 m² (200 ft²) for a coarse-textured soil up to 185.8 m² (2,000 ft²) for a fine textured soil. It should be noted that even in coarse soil conditions the **minimum trench bottom size** for any subsurface sewage works is **37 m² (400 ft²)**.

Figure 7.1 Distribution of Effluent to Level Chamber Systems

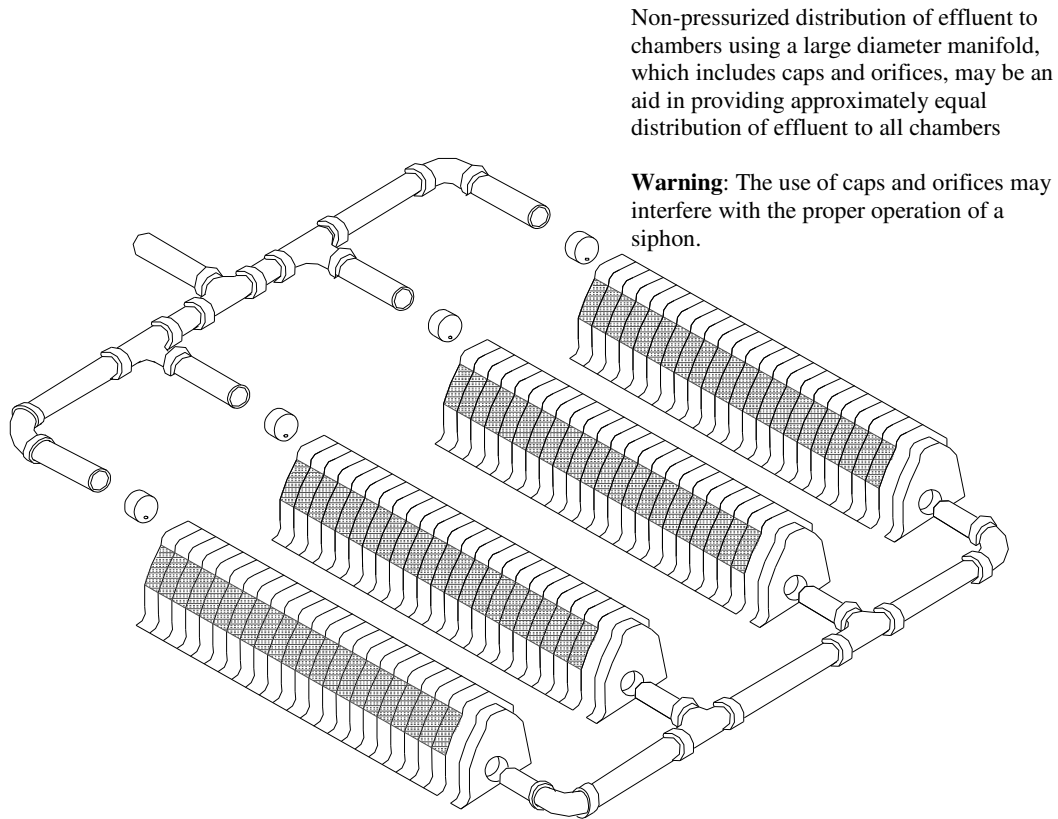

Pressurized distribution of effluent to chambers with a small diameter manifold which include properly sized orifices may be considered acceptable in providing approximately equal distribution of effluent to all chambers.

The installation of an equalization header is always recommended and must be installed in any level chamber type field where approximately equal distribution of effluent to laterals cannot be assured.

Where approved by the local authority and the chamber system is supplied with effluent from a packaged sewage treatment plant, there may be a 30% reduction in the area of lateral trench bottom, as indicated in 12.3.

Chambers are typically installed in 0.9 m (3 ft) wide trenches, separated by at least 1.8 m (6 ft), edge to edge. Soil backfill is placed along the chamber sidewall area to a minimum compacted (walked-in) height of eight inches above the trench bottom. Additional backfill is usually placed to a minimum compacted height of 30.5 cm (12 in) above the chamber. The typical maximum backfill height above the chamber is 61 cm (24 in). Chambers are usually made of sturdy plastic and do not require gravel fill. Typically, they consist of series of large, two to four foot wide modular plastic arch segments that snap together.

A solid-end plate is installed at the distal end of the chamber drainfield line. Individual chamber trenches should be leveled in all directions and follow the contour of the ground surface elevation without any dams or other water stops. Chamber systems installed on sloping sites may use distribution devices or step-downs when necessary to channel the level of the leaching chamber segments from upper to lower elevations. The manufacturer's installation instructions should be followed.

The trench bottom area for a treatment field using chambers may be calculated using 1.1 times (to a maximum of 900 mm (36 in)) the actual width of the chamber when effluent is distributed in the trench by gravity, or may be calculated using 1.3 times (to a maximum of 900 mm (36 in)) the actual width of the chamber when the effluent is distributed using pressure distribution lateral piping. The trench bottom area calculated for a system using septic tank effluent should not exceed the soil absorption system size that would be allowed if using secondary treated effluent and no chamber. When receiving secondary treated effluent, the calculation of the soil infiltration surface required may be based on 1.1 times the actual width of the chamber if pressure distribution is used. All reduction factors (eg. 1.1, 1.3, 30%) must be accepted by the local authority.

The following three sections provide information regarding different methods of distributing effluent to chamber fields.

7.3.1 Conventional Gravity Flow Chamber System

In these systems sewage effluent is pumped or gravity fed to a distribution point and then fed by gravity to a field. A conventional gravity flow chamber system should have at least two trenches. The length of individual trenches should not exceed 30 m (100 ft) and the trenches should all be about the same length. A distribution box is required to ensure that all trenches receive the same volume of effluent. The chambers are manifolded with conventional plastic pipe such as high-density polyethylene. The inlet invert is approximately 20.3 cm (8 in) above the trench bottom. Some suitable method to dissipate the hydraulic energy of the effluent is required to prevent soil erosion or disturbance of the trench bottom. This can be accomplished with splash pans supplied by the manufacturer or by placing 100 mm (4 in) of gravel in the most upstream 3 m (10 ft) of all weeping lateral trenches or other area that receives effluent. The *Trench Bottom Sizing Worksheet* (Appendix 3) can be used to aid in designing this type of system. The trench bottom area for a treatment field using chambers may be calculated using 1.1 times (to a maximum of 900 mm (36 in)) the actual width of the chamber when effluent is distributed in the trench by gravity. The trench bottom area calculated for a system using septic tank effluent should not exceed the soil adsorption system size that would be allowed if using secondary treated effluent.

7.3.2 Gravity Chamber System with Pressurized Delivery

These systems are gravity chamber systems with pressurized delivery to the chambers. In these systems a 1¼ in. or 1½ in. pipe from a sewage pump is buried below frost level. TEE fittings on this pressure pipe lead to risers that terminate just inside the end chamber of each lateral. The floor of the chamber must be protected from soil erosion at the point where the discharge pipe

enters. This can be accomplished by using several layers of geotextile (landscape cloth) or PVC window screen that is about 0.3 m^2 (3 ft^2) with a hole in the middle to accommodate the discharge pipe. The *Trench Bottom Sizing Worksheet* (Appendix 3) can be used to aid in designing this type of system. The trench bottom area for a treatment field using chambers may be calculated using 1.1 times (to a maximum of 900 mm (36 in)) the actual width of the chamber when effluent is distributed in the trench by gravity. The trench bottom area calculated for a system using septic tank effluent should not exceed the soil adsorption system size that would be allowed if using secondary treated effluent.

7.3.3 Pressure Chamber System

Pressure chamber systems function much like conventional chamber systems. The difference is that sewage is evenly distributed through all of the chambers simultaneously whereas in the conventional system the sewage flows from one chamber to the next. The trench bottom area for a treatment field using chambers may be calculated using 1.3 times (to a maximum of 900 mm (36 in)) the actual width of the chamber when the effluent is distributed using pressure distribution lateral piping. The trench bottom area calculated for a system using septic tank effluent should not exceed the soil adsorption system size that would be allowed if using secondary treated effluent. When receiving secondary treated effluent the effluent loading rate and calculation of the soil infiltration surface required may be based on 1.1 times the actual width of the chamber.

There is no maximum row length. Although these systems can be smaller, the overall cost will likely be higher than a gravity system because a more expensive pump will be necessary. The effluent must also be filtered to prevent blockage of discharge orifices. Pressure chamber systems are well suited to locations where soil is extremely sandy or on long narrow sites where there isn't room for more than one lateral. The design of a pressure chamber system is somewhat complex. The object is to have a sewage effluent pump, pressure distribution line and perforations in the line all properly sized and spaced to achieve a 1.5 m (5 ft) squirt height along the entire length of the system (see Appendix 12). It is extremely important that all variables are properly matched so that the end result is a practical system. For example, a system design requiring a pump capable of pumping 189 L (50 US gals) a minute at 9 m (30 ft) of head is not practical. Typical doses pumped from the second compartment of a septic tank rarely exceed 136 L (30 US gals) at a time. Even though it is possible to purchase high capacity pumps such a pump would run less than a minute to draw down the level in the second compartment. Most pump manufacturers stipulate that pumps must run for more than a minute each time they cycle. The *Pressure Chamber System Sizing Worksheet* (Appendix 3A) should be followed to properly design the system. The worksheet is used to determine the following criteria:

- ❑ Total length of the chamber system.
- ❑ The diameter of the lateral, the diameter of the orifices, the number and spacing of the orifices.
- ❑ The total flow from all of the orifices.
- ❑ The size of the effluent delivery pipe.
- ❑ The pressure loss due to pipe length and fittings.
- ❑ The pressure head loss due to friction.

- ❑ Total pressure head required at pump.
- ❑ Flow rate and pressure head required from pump.

In section 7.3.4, the installation of a 61 m (200 lineal ft) system is designed to serve a three-bedroom home in an area with good absorptive soil conditions. An equivalent pressure chamber system is described below. For the purposes of this example, it is assumed that there is a septic tank buried 3 m (10 ft) deep with sewage pumped a distance of 18 m (60 ft) to a single row of chambers that is 49 m (160 ft) long. The terrain is relatively level.

If a 5 cm (2 in) pressure distribution lateral is used then 39 orifices that are 0.5 cm (3/16 in) in diameter would be required. The orifices would be spaced at 124 cm (49 in) intervals. A pump capable of producing 113 L (30 US gals) per minute at 15 feet of pressure head is required. **Note: Any deviations in pipe length, pump lift, pipe fittings, pipe or orifice diameter will require the system to be redesigned and the pump specifications recalculated using the *Pressure Chamber System Sizing Worksheet* (Appendix 3A).**

7.3.4 Sizing The System

In areas where it has been established that the soil has good absorptive capacity a standard design of 61 m of chambers may be approved. It is important to remember that a 61 lineal metre (200 lineal ft) system must be approved by the local health region prior to installation because variances in occupancy, site location and soil types may require larger systems to be installed.

In those situations where a standard 61 m long chamber system is not acceptable, it is necessary to design a system based on the calculations described in the following sections.

7.3.5 Calculating System Size Using Soil Texture Classification Method (This section applies to all types of soil chamber systems)

The information in Appendix 15 '*Soil Tests*' is used to determine the total area of trench bottom or soil treatment area required, based on conventional absorption field systems.

Both the daily ability of the soil to absorb moisture (field loading rate) and the daily volume of effluent need to be calculated. There are two ways to determine the field loading rate. When a soil percolation test is conducted the percolation rate can be converted to a loading rate in liters per square meter or gallons per square foot using Appendix 1. The preferred way to determine a field loading rate is to use the soil texture classification method to arrive at a rate that is also expressed in volume per area. Appendix 1 or Appendix 2 can be used to estimate typical volumes for various occupancies. When the absorption rate and the volume are known Appendix 1 can be used to determine the total soil treatment area required.

Soils determined to be "not suitable without further testing" as outlined in Appendix 15, pg. A-41, will require further analysis. Additional information is required in order to determine if a narrower and longer system is an option for adequate treatment of wastewater.

- A soil structure analysis/grade analysis should be conducted as outlined in Appendix 15 or by a soils laboratory
- The resulting soil texture and structure (shape and grade) as well as the infiltration loading rate, slope of the site, and distance to a restrictive layer should be used to determine the width and area of a system according to the "Effluent Soil Loading Rates and Linear Loading Rates" table in Appendix 15.

Note: A soil percolation test or soil texture classification method may be the only acceptable method depending on the location of the system and the policy of the local municipality and/or health region.

The total soil treatment areas in Appendix 1 are based on areas required for conventional absorption field systems. Because chamber systems make more efficient use of the trench area they are considered to be 1.1 or 1.3 times wider than their actual size. There are several chamber designs and sizes available. The effective soil treatment area of any chamber design is determined by multiplying the actual chamber width by 1.1 (gravity) or 1.3 (pressure). For example, a chamber with actual width of 55.9 cm (22 in) is deemed to be equivalent to a width of 61.5 cm (24.2 in), if the effluent is distributed by gravity. A chamber with actual width of 55.9 cm (22 in) is deemed to be equivalent to a width of 72.7 cm (28.6 in), if the effluent is distributed by a pressure distribution system. This equivalent width cannot be greater than 90 cm (36 in). Therefore, a chamber system with actual measurements of 55.9 cm (22 in) by 122 cm (48 in) covers an area of 0.7 m² (7.5 ft²). However because the width is deemed to be equivalent to 72.7 cm (28.6 in), it is deemed to provide 0.89 m² (9.53 ft²) of soil treatment area. The required number of chambers is determined by dividing the total soil treatment area required by the effective soil treatment area provided by each chamber.

The *Pressure Chamber System Sizing Worksheet* (Appendix 3A) or *Trench Bottom Sizing Worksheet* (Appendix 3) can be used as an aid in calculations.

Examples of systems designed for three-bedroom homes in different soil conditions. The daily sewage volume in each case is estimated to be 1530 L (337.5 gals) Appendix 1 is used to determine size of system.

□ **Loamy Sand Soil** (It is assumed that the soil has a percolation rate of 7.2)

Treatment area provided by each 55.8 cm x 122 cm (22 in x 48 in) chamber is considered to be 0.89 m² (9.53 ft²) if served by a pressure distribution system.

3 bedroom house effluent volume: 1530 L (337.5 gals) per day
Soil loading rate: 30.82 L/m² (0.64 gals/ft²)

Area of trench bottom in m² (ft²) = $\frac{\text{daily effluent volume L (gals)}}{\text{Soil Loading Rate L/m}^2 \text{ (gals/ft}^2\text{)}}$

$$\text{Area required} = \frac{1530 \text{ L (337.5 gals)}}{30.82 \text{ L/m}^2 \text{ (0.64 gals/ft}^2\text{)}}$$

$$\text{Area required} = 49.32 \text{ m}^2 \text{ (531.51 ft}^2\text{)}$$

Number of chambers required = $\frac{\text{Area of trench bottom in m}^2 \text{ (ft}^2\text{)}}{\text{Equivalent treatment area of each chamber}}$

$$\text{Number of chambers required} = \frac{49.32 \text{ m}^2 \text{ (531.51 ft}^2\text{)}}{0.89 \text{ m}^2 \text{ (9.53 ft}^2\text{)}}$$

$$\text{Number of chambers required} = 56$$

□ **Silt Soil**

It is assumed that the soil has a percolation rate of 35 which equals a loading rate of 13.78 L/m² (0.28 gals/ft²). In these conditions a trench bottom area of 111.03 m² (1205.4 ft²) is required. 125 chambers that are 55.8 cm x 112 cm (22 in x 48 in) provide an equivalent of 111.25 m² (1191 ft²) of soil treatment area.

□ **Clay Loam Soil**

It is assumed that the soil has a percolation rate of 58 which equals a loading rate of 10.71 L/m² (0.22 gals/ft²). In these conditions, a trench bottom area of 142.9 m² (1534.1 ft²) is required. 161 chambers that are 55.8 cm x 112 cm (22 in x 48 in) provide 143.3 m² (1534.3 ft²) of soil treatment area.

7.4 INSTALLATION

7.4.1 Site Selection

Chamber systems are suitable for lots with tight sizing constraints or where water tables or bedrock limit the depth of the drain field. The chamber system should be located so as not to impact on the water table. If a contractor is in doubt as to what would be considered an appropriate separation, they are strongly urged to contact the local health region before installation.

Chamber systems should not be installed in flood plains, drainage ways or depressions unless flood protection is provided. In addition to the area needed for the absorption field, space should be reserved for possible expansion.

7.4.2 Setback Requirements

A chamber system, measured from any part of a lateral trench, shall not be located within:

<input type="checkbox"/> Building	9 m (30 ft)
<input type="checkbox"/> Recreation Areas	60 m (200 ft)
<input type="checkbox"/> Property Boundary	3 m (10 ft)
<input type="checkbox"/> Walk/Driveway	1.5 m (5 ft)
<input type="checkbox"/> Cut or embankment	3 m (10 ft)
<input type="checkbox"/> Ground water table	1.5 m (5 ft)
<input type="checkbox"/> Well*	15 m (50 ft)
<input type="checkbox"/> Water Course	15 m (50 ft)

* Unless otherwise approved by the local authority (through consultation with Saskatchewan Ministry of Environment officials), the setback distance from a well that is used as a water source for a municipal waterworks should be at least 75 m (250 ft) in the case of a small municipality (less than 1,000 population) and at least 225 m (750 ft) in the case of a large municipality (1,000 or more population).

7.4.3 Inspection

Before the system is covered the local health region shall be contacted to request an inspection. A Public Health Inspector with the local health region may inspect the installation or provide approval to proceed with the covering of the system.

7.5 CARE AND MAINTENANCE

In order to protect from freezing, the chamber site should be kept covered during the winter months with at least 0.5 m (2 ft) of snow or straw bales when snow cover is inadequate. Grass cover should be established over the entire site. Shrubs or trees should not be planted on the top of the chamber trenches.

8.1 DEFINITION

An Absorption Field System is a series of perforated pipes laid in trenches, which spread effluent from a septic tank over a medium of stone before entering the surrounding soil. (Figure 8.1)

Figure 8.1

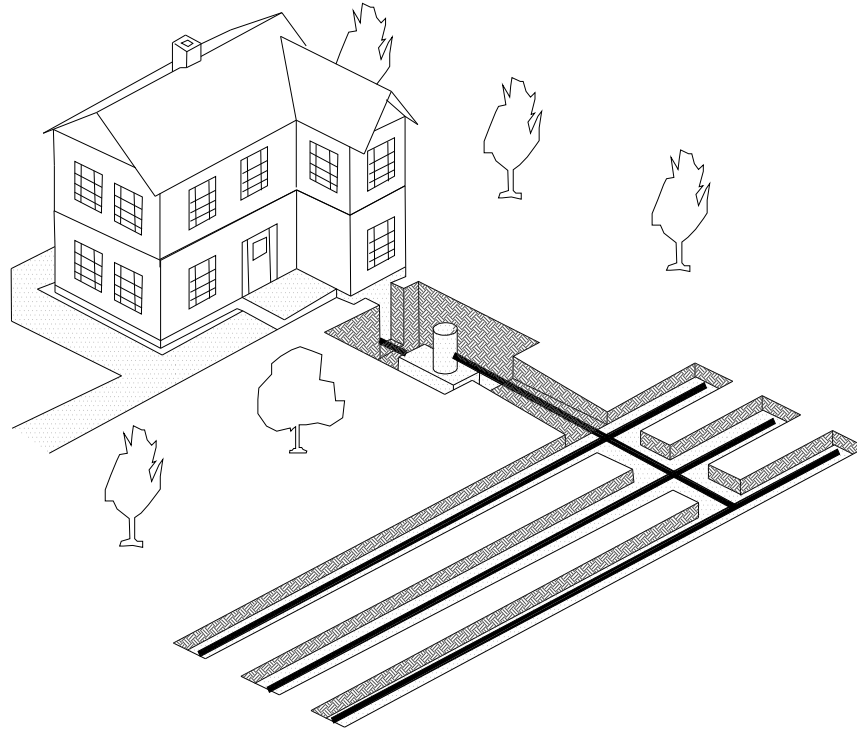

8.2 FUNCTION

The partially treated wastewater (primary effluent) leaving the septic tank is discharged below the ground surface into a drainage field. Here the water receives secondary treatment by natural processes in the soil.

8.3 DESIGN

Except as provided in 8.3.3, an absorption field should have not less than 37 m² (400 ft²) of weeping lateral trench area.

An absorption field should not use serial distribution (effluent passes through one trench to reach another trench) as a method to distribute effluent to weeping lateral trenches. Effluent should be distributed to each lateral evenly. All piping used or in conjunction with absorption field systems must be of a type that is acceptable to the local health region.

Where approved by the local authority and the absorption field is:

- ❑ supplied with effluent from a packaged sewage treatment plant, there may be a 30% reduction in the area of weeping lateral trench bottom, as indicated in 8.3.3.1, or
- ❑ supplied with effluent from a septic tank and pressure distribution, there may be a 20% reduction in the area of lateral trench bottom, as indicated in 8.3.3.1.

A weeping lateral trench should:

- ❑ not be greater than 900 mm (3 ft) in depth,
- ❑ not be less than 450 mm (18 in) or greater than 900 mm (3 ft) in width when using weeping lateral trench media,
- ❑ have a nominally level bottom,
- ❑ include a void space created by weeping lateral trench media at the bottom of the trench filling the entire width of the trench to a depth of 300 mm (1 ft),
- ❑ be provided with a minimum of 900 mm (3 ft) of earth between it and another lateral trench, and
- ❑ have a 75 mm to 100 mm (3 to 4 in) layer of straw or equivalent material covering the media gravel to prevent the migration of soil into the gravel.

Weeping Lateral Trench

Figure 8.2

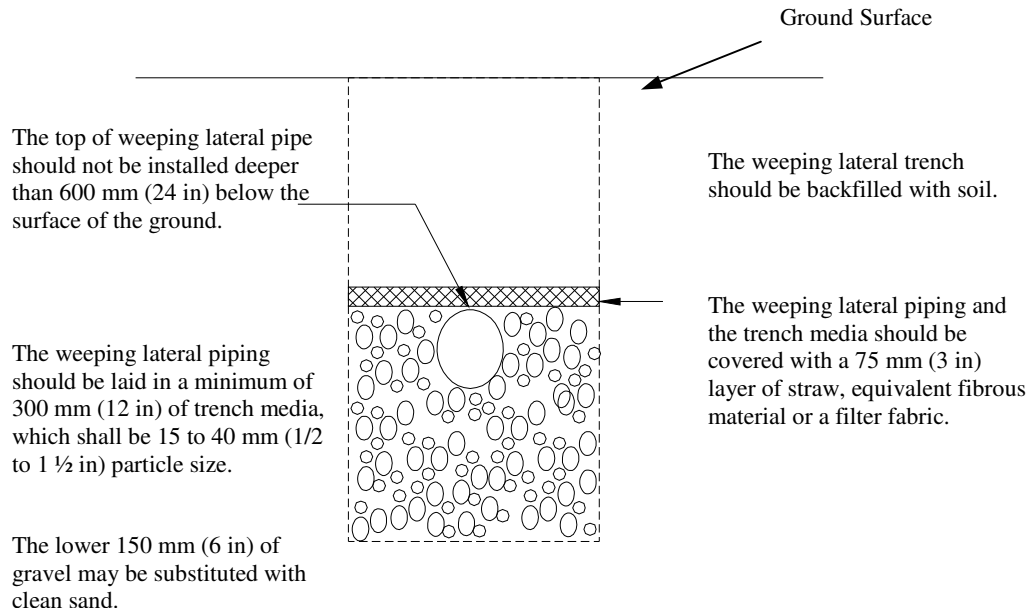

The weeping lateral trench should have a minimum width of 450 mm (18 in) and a maximum width of 900 mm (36 in) and shall have a nominally level bottom.

A weeping/pressure distribution lateral pipe should:

- ❑ be laid nominally level at a maximum depth of 600 mm (2 ft) measured from the top of the pipe to the ground surface,
- ❑ be installed with the top of the pipe at the top of the void space,
- ❑ be installed, when connected to a field header, at the same elevation as the other lateral pipes, and
- ❑ be installed at the same elevation as other lateral pipes when connected to a field header.

When used in a system, a distribution box should:

- ❑ have an internal dimension not exceeding 300 mm (12 in),
- ❑ provide relatively equal distribution to all outlets, and
- ❑ be readily accessible for inspection and service.

Figure 8.3

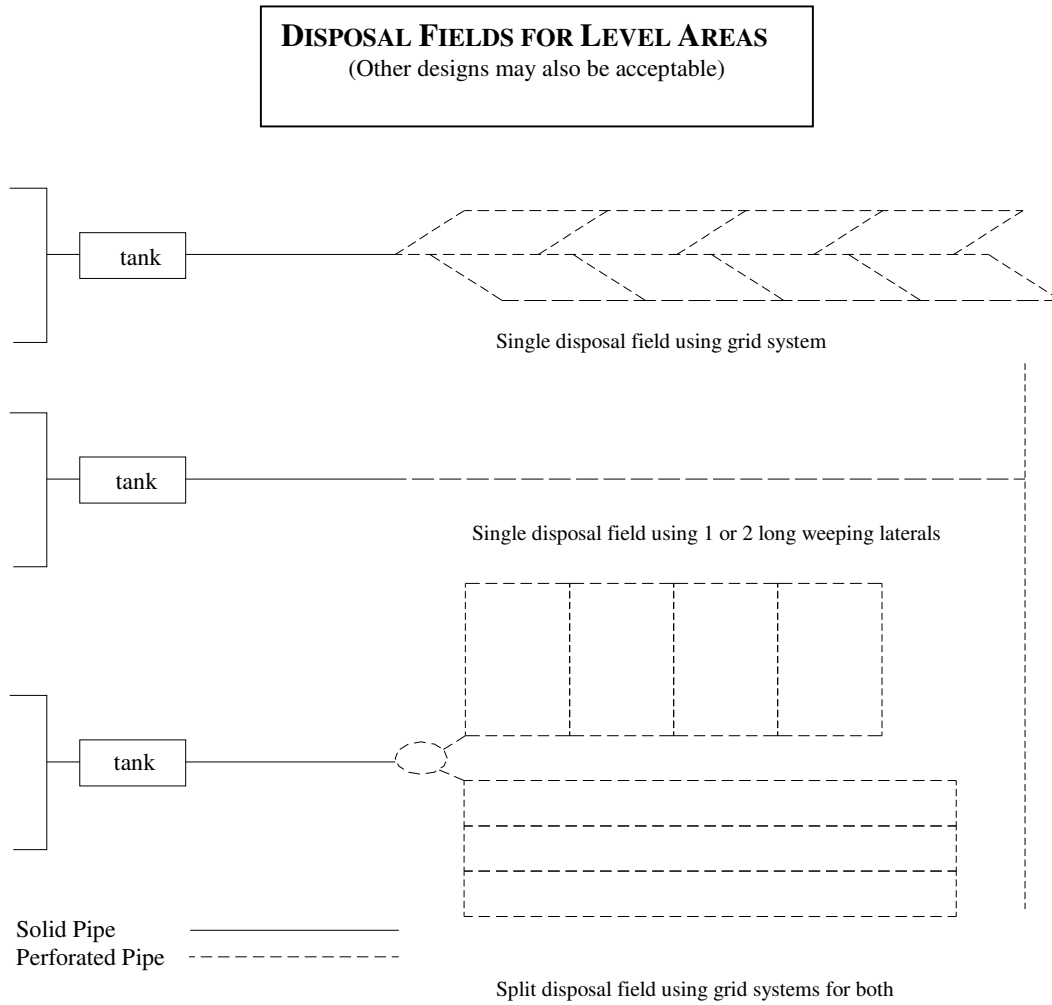
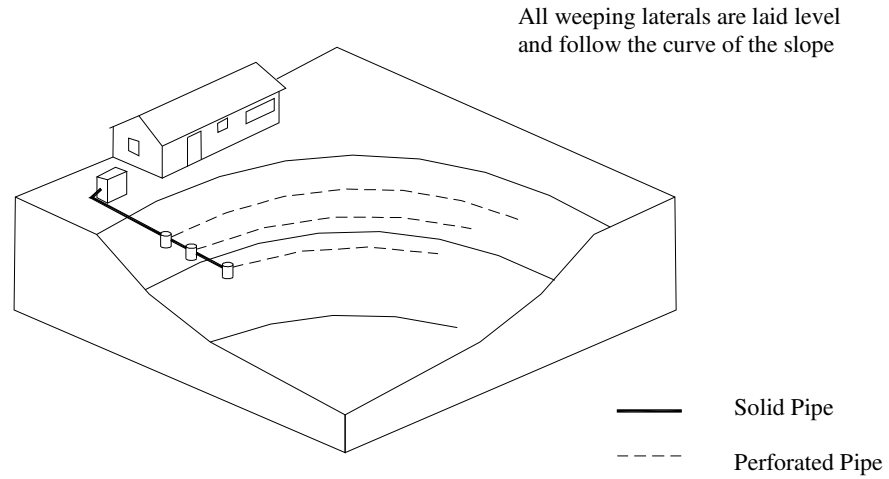

Figure 8.4

Disposal Fields for Sloping Areas Using Drop Box
 (Other designs may also be acceptable)



Drop Box

Plan View

Inlet from septic tank or previous drop box.

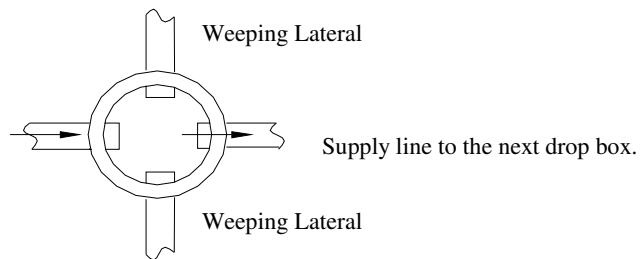

Section View

Inlet from septic tank or previous drop box should be:
 25 mm (1 in) above outlet.
 75 mm (3 in) above the weeping lateral(s).

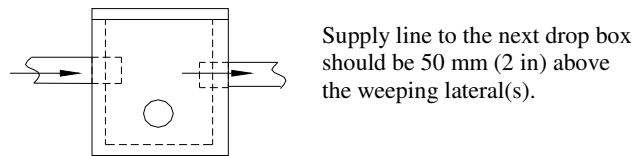

Piping materials used in the construction of pressure distribution laterals for a weeping lateral trench should:

- ❑ be smooth, rigid plastic piping, and
- ❑ be certified for a pressure application by a testing agency recognized by the Standards Council of Canada, or acceptable to the local health region.

Weeping lateral trench media should:

- ❑ be materials that maintain structural integrity and will not be degraded by the environment in the disposal field trench,
- ❑ consist of 12 mm (0.5 in) to 50 mm (2 in) particle size material,
- ❑ not contain more than 5% fines, silt or clay. Be covered to prevent migration of soil particles into the void space around the media by:
 - 75 mm (3 in) of non-oil seed straw, or other equivalent fibrous material, or
 - a filter fabric.

When clean/washed graded stone, or clean/washed graded stone and sand is used as a weeping lateral trench media it should be placed across the full width of the trench and be:

- ❑ a 300 mm (1 ft) layer of clean/washed graded stone having a particle size of 12 mm (0.5 in) to 40 mm (1.5 in), or
- ❑ a 150 mm (6 in) layer of clean sand covered by a 150 mm (6 in) layer of gravel having a particle size of 12 mm (0.5 in) to 40 mm (1.5 in) , and
- ❑ not more than 5% fines, silt or clay.

Construction should be done only when the soil is dry, as excavation equipment can “smear” the soil during digging. Smearing seals pores and greatly retards water movement from the trench into the surrounding soil.

Figure 8.5

**Disposal Fields Using Bi-Level Cross
(Other designs may also be acceptable)**

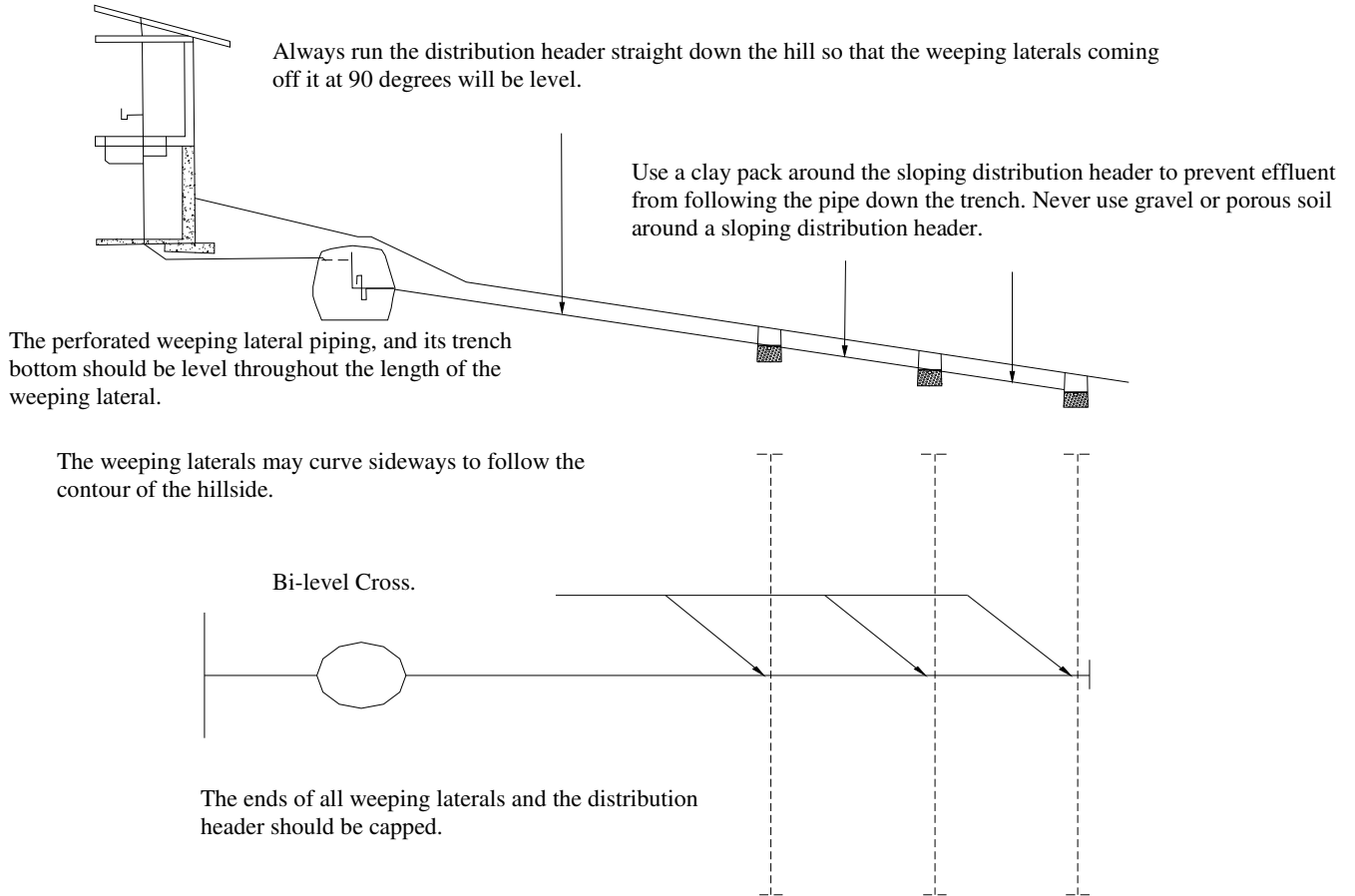
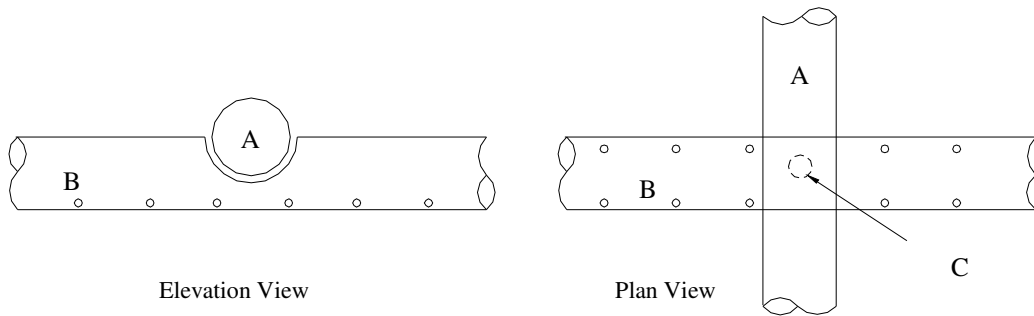

Figure 8.6**Bi-Level Cross**

- A. Watertight distribution header, surrounded by clay pack, not gravel.
- B. Weeping Lateral.
- C. Hole in the bottom of the distribution header feeds each weeping lateral pipe. The hole size will vary with the number of weeping lateral pipes to be “fed”, so that each weeping lateral pipe will get its share of each flush. For steeper slopes on the distribution header, increase the hole size. Bi-level crosses are not satisfactory for installation on slopes steeper than about 10%. Cross wrap the two pipes together with plastic tape.

Suggested Hole Sizes for Gravity Distribution of Effluent
(Hole sizes may vary under different conditions)

Number of Weeping Laterals	Size of Holes
2	75 mm (3 in)
3 - 4	50 mm (2 in)
5 - 6	38 mm (1 ½ in)
7 - 10	32 mm (1 ¼ in)
More than 10	25 mm (1 in)

8.3.1 Gravity Effluent Distribution Systems

Gravity systems (standard systems) are designed for serial distribution. Many of these systems are in fact "designed" to fail serially – as one weeping lateral trench clogs, the effluent will flow into the next lateral, etc., until the last line clogs and the entire field is due for replacement. Although these systems are designed in this manner, a well-maintained serial distribution system can last for many years. Gravity effluent distribution system should be designed to provide approximately equal distribution of effluent to each weeping lateral trench.

8.3.2 Pressure Effluent Distribution Systems

Pressure distribution systems utilize a pump and provide for even utilization of the entire system, in turn allowing for a dosing-resting cycle so that re-oxygenation and rejuvenation of the absorption field can occur. In other words, such systems are pressurized and designed to "dose" the absorption field, wetting the entire leaching area at one time. The field should then have time to dry out and aerate before the next dose is applied. For this reason, it is important to maintain the dosing volume specified in the system design.

A pressure distribution lateral pipe system should include:

- a design to distribute effluent uniformly throughout the entire length of weeping lateral trench in an absorption field.
- a minimum pressure head of 1500 mm (5 ft) at the most remote orifice with not more than 10% flow variance between any individual orifice.
- the number of orifices per distribution lateral piping sized as specified in Appendix 4.
- orifices in the distribution laterals designed to have:
 - a minimum diameter of 3.2 mm (1/8 in);
 - be evenly spaced at a distance of not greater than 1500 mm (60 in);
 - a volume per flush not exceeding 20% of the expected daily volume (Numerous light applications provide better effluent treatment conditions);
 - and,
 - a screen to prevent particles from greater than 3.2 mm (1/8 in) from being discharged into laterals.

8.3.3 Sizing The System

Both the daily ability of the soil to absorb moisture (field loading rate) and the daily volume of effluent need to be calculated. There are two ways to determine the field-loading rate: a percolation test or a soils analysis.

Soils determined to be "not suitable without further testing" as outlined in Appendix 15, pg. A-41, will require further analysis. Additional information is required in order to determine if a narrower and longer system is an option for adequate treatment of wastewater.

- A soil structure analysis/grade analysis should be conducted as outlined in Appendix 15 or by a soils laboratory
- The resulting soil texture and structure (shape and grade) as well as the infiltration loading rate, slope of the site, and distance to a restrictive layer should be used to determine the width and area of a system according to the "Effluent Soil Loading Rates and Linear Loading Rates" table in Appendix 15.

Note: A soil percolation test or soil texture classification method may be the only acceptable method depending on the location of the system and the policy of the local municipality and/or health region.

8.3.3.1 Calculating System Size Using Soil Percolation Test

When using the results of a percolation test to size a system, the total area of weeping tile trench bottom required shall be determined from one of the following formulas:

$$\square \text{ Square Metres} = \frac{\text{LitresPerDay}}{\left\{ \left\{ \frac{3}{\sqrt{\text{PercolationRate}}} \right\} \times 27.36 \right\}}$$

Where

Square metres = Trench bottom area (not including walls)

Litres per day = Expected sewage volume in litres/day

Percolation rate = Percolation rate in minutes/25 mm

$$\square \text{ Square Feet} = \frac{\text{GallonsPerDay}}{\left\{ \left\{ \frac{3}{\sqrt{\text{PercolationRate}}} \right\} \times 0.56 \right\}}$$

Where

Square Feet = Trench bottom area (not including trench walls)

Gallons per Day = Expected sewage volume in gallons/day

Percolation Rate = Percolation rate in minutes/inch

Note: A table of loading rates, square roots of percolation rates, and calculations using this formula is provided for convenience in Appendix 1.

When a soil percolation test is conducted (Appendix 8), the percolation rate can be converted to a loading rate in liters per square meter or gallons per square foot using Appendix 1. The other way to determine a field loading rate is to use the soil texture classification method (Appendix 15) to arrive at a rate that is also expressed in volume per area.

8.3.3.2 Calculating System Size Using Soil Texture Classification Method

Appendix 1 or Appendix 2 can be used to estimate typical volumes for various occupancies. When the absorption rate and the volume are known, Appendix 1 can be used to determine the total soil treatment area required.

Calculation Examples:

The following examples are based on a 3 bedroom house in clay loam, silt, and loamy sand soils.

House Effluent Volumes found in Appendix 1.

Sizing Using Soil Texture Loading Rates found in Appendix 15.

□ Loamy Sand Soils

3 bedroom house effluent volume:	1530 L (337.5 gals)
Soil loading rate:	30.87 L/m ² (0.63 gals/ft ²)
Trench area required	= $\frac{\text{Effluent Volume L(gals)}}{\text{Soil Loading Rate L/m}^2 \text{ (gals/ft}^2\text{)}}$
	= $\frac{1530 \text{ L (337.5 gals)}}{30.87 \text{ L/m}^2 \text{ (0.63 gals/ft}^2\text{)}}$
	= 49.56 m ² (535.7 ft ²)
If 0.6 m (2 ft) trenches are used:	= $\frac{49.56 \text{ m}^2 \text{ (535.7 ft}^2\text{)}}{0.6 \text{ m (2 ft)}}$
	= 83 m (272 ft) of trench is required

□ Silt Loam Soils

3 bedroom house effluent volume:	1530 L (337.5 gals)
Soil loading rate:	12.25 L/m ² (0.25 gals/ft ²)
Trench area required	= $\frac{\text{Effluent Volume L(gals)}}{\text{Soil Loading Rate L/m}^2 \text{ (gals/ft}^2\text{)}}$
	= $\frac{1530 \text{ L (337.5 gals)}}{12.25 \text{ L (0.25 gals/ft}^2\text{)}}$
	= 124.8 m ² (1350 ft ²)

$$\begin{aligned} \text{If 0.6 m (2 ft) trenches are used:} &= \frac{124.8 \text{ m}^2 (1350 \text{ ft}^2)}{0.6 \text{ m (2 ft)}} \\ &= \mathbf{208 \text{ m (682 ft) of trench is required}} \end{aligned}$$

□ Clay Loam Soils

$$\begin{aligned} \text{3 bedroom house effluent volume:} & 1530 \text{ L (337.5 gals)} \\ \text{Soil loading rate:} & 10.78 \text{ L/m}^2 (0.22 \text{ gals/ft}^2) \end{aligned}$$

$$\text{Trench area required} = \frac{\text{Effluent Volume L (gals)}}{\text{Soil Loading Rate L/m}^2 (\text{gals/ft}^2)}$$

$$= \frac{1530 (337.5 \text{ gals})}{10.78 \text{ L/m}^2 (0.22 \text{ gals/ft}^2)}$$

$$= 141.9 \text{ m}^2 (1534 \text{ ft}^2)$$

$$\text{If 0.6 m (2 ft) trenches are used:} = \frac{141.9 \text{ m}^2 (1534 \text{ ft}^2)}{0.6 \text{ m (2 ft)}}$$

$$= \mathbf{236 \text{ m (774 ft) of trench is required}}$$

□ Clay Soils

Clay soil is not suitable for absorption field systems.

8.4 INSTALLATION

8.4.1 Site Selection

Absorption fields should be located so as not to impact on the water table. As a general guide to local authorities and installers, all health regions in Saskatchewan view 1.5 metres (5 ft) as an appropriate minimum vertical separation. It is difficult to identify such a distance as water tables fluctuate in response to variable rainfall and run off conditions. If unsure, contact the local health region prior to installation.

Absorption fields should not be installed in flood plains, drainage ways, or depressions unless flood protection is provided.

8.4.2 Setback Requirements

An absorption field system, measured from any part of the lateral trench, shall have a minimum setback distance as follows:

- | | |
|---|---------------|
| <input type="checkbox"/> Building | 9 m (30 ft) |
| <input type="checkbox"/> Recreation Areas | 60 m (200 ft) |
| <input type="checkbox"/> Property Boundary | 3 m (10 ft) |
| <input type="checkbox"/> Walk/Driveway | 1.5 m (5 ft) |
| <input type="checkbox"/> Cut or embankment | 3 m (10 ft) |
| <input type="checkbox"/> Ground water table | 1.5 m (5 ft) |
| <input type="checkbox"/> Well* | 15 m (50 ft) |
| <input type="checkbox"/> Water Course | 15 m (50 ft) |

* Unless otherwise approved by the local authority (through consultation with Saskatchewan Ministry of Environment officials), the setback distance from a well that is used as a water source for a municipal waterworks should be at least 75 m (250 ft) in the case of a small municipality (less than 1,000 population) and at least 225 m (750 ft) in the case of a large municipality (1,000 or more population).

8.4.3 Inspection

Before the system is covered the local health region shall be contacted to request an inspection. A Public Health Inspector with the local health region may inspect the installation or provide approval to proceed with the covering of the system.

8.5 CARE AND MAINTENANCE

Care should be taken never to drive over the absorption field before, during, or after construction. To do so may compact soil and crack and/or tilt the pipes, which will seriously limit the effectiveness of the system.

In order to prevent freezing during the winter months, lateral trenches should be covered during the winter months with:

- at least 0.5 m (1.75 ft) of snow, or
- the use of straw bales when snow cover is inadequate.

Grass cover should be established over the entire site. Shrubs or trees should not be planted on the top of the trenches.

9.1 TYPE I MOUNDS

9.1.1 DEFINITION

Mounds are an excellent treatment and disposal choice, however, it cannot be overemphasized that careful planning and design, filter media selection, construction and maintenance of the mound is critical. Mound systems require an environment for microbial activity so care in the material selection and construction steps must be taken to provide such an environment.

A Type I Mound is a wastewater treatment system consisting of a series of perforated laterals on a graded stone bed above the natural soil surface. These perforated laterals receive wastewater effluent from a septic tank through a distribution box. The effluent is transmitted into the graded stone bed and natural soil for final treatment and disposal.

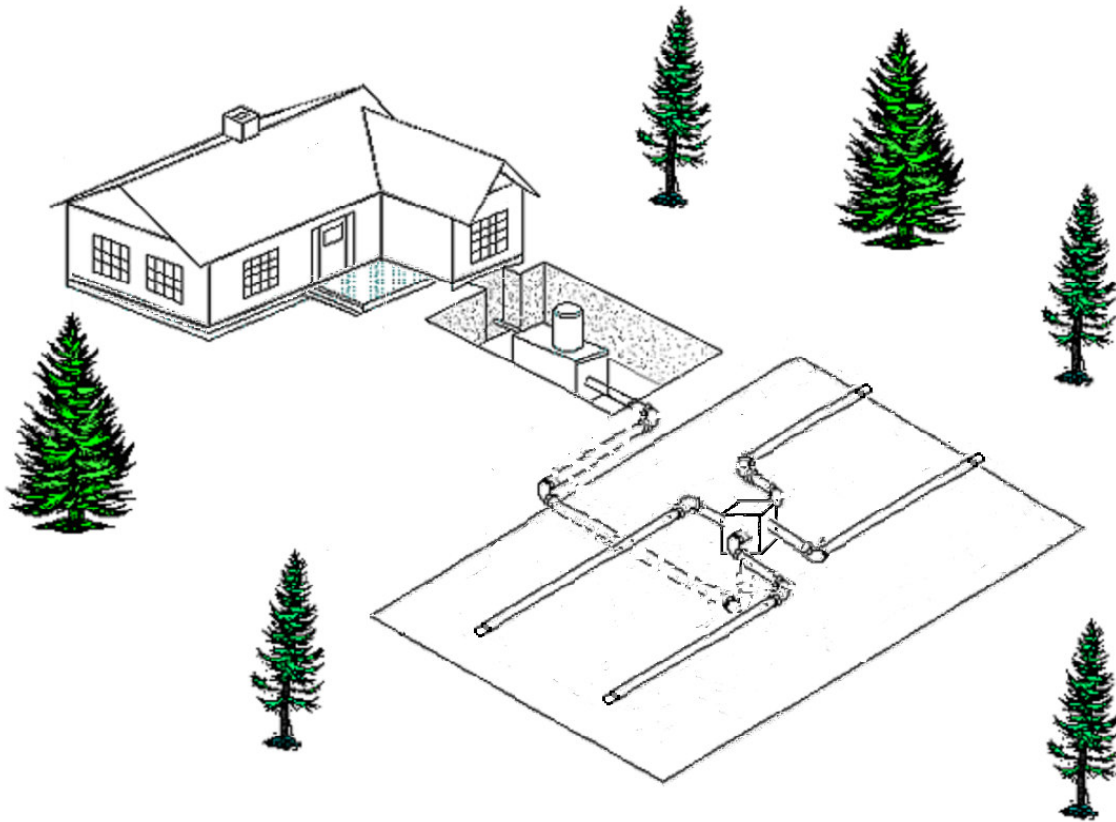

9.1.2 FUNCTION

Sewage mounds have two key functions: to dispose of effluent from the septic tanks and to distribute this effluent in a manner allowing adequate natural wastewater treatment in the stone bed and natural soil before the effluent reaches the underlying groundwater.

Sewage effluent is pumped from the septic tank to the distribution box and then allowed to flow by gravity out to the distribution laterals within the mound on to the prepared stone. Effluent is spread over the graded stone and allowed to percolate through this layer removing the organic load in the effluent. The effluent undergoes biological treatment in the underlying natural soil, which is considered the infiltrative surface.

9.1.3 DESIGN

Proper sizing is key to ensuring the mound system meets the landowner's needs, both current and future. How the mound is designed and constructed will determine the effectiveness of this type of system in handling the sewage volumes produced. Under-sizing a mound will result in certain failure of this type of system.

All piping used in or in conjunction with a mound system must be of a type that is acceptable to the local health region.

The following concepts should be included in the design and construction process of the mound to ensure proper performance:

- ❑ Plow topsoil before placement of the fill material.
- ❑ Uniformly distribute the effluent over the seepage area.

9.1.3.1 Sizing The System

The amount of graded stone in the stone layer is determined by the infiltration area needed (based on expected daily volume of sewage and underlying soils) and the minimum depth of 450 mm (18 in). For example, a 4 bedroom home, that has an estimated sewage flow of 2045 L (450 gals) per day and is located on a sandy loam (loading rate of 22.05 L/m² (0.45 g/ft²)), requires a base area of 93 m² (1000 ft²). The minimum volume of graded stone required in this case is calculated by multiplying the area of 93 m² (1000 ft²) by a depth of stone of 0.45 m (18 in), which equals 41.9 m³ (1500 ft³). Appendix 7A can be used to assist in system sizing.

The infiltration area of the mound is that area of soil covered by the mound and that receives effluent. The berms located at the ends of the mound are necessary for mound construction but the soil under these berms is not considered part of the total infiltrative area. Only the area beneath the graded stone is considered part of the infiltrative area. To prevent seepage at the toe of the berm, the area of the soil receiving the effluent must be sized to absorb the expected loads.

A Type I Mound is sized according to the type of underlying natural soil. The information in Appendix 15 'Soil Tests' is used to determine the type of underlying soil, which will determine the minimum volume of graded stone to be used.

Soils determined to be "not suitable without further testing" as outlined in Appendix 15, pg. A-41, will require further analysis. Additional information is required in order to determine if an alternative design in a type I mound is an option for adequate treatment of wastewater.

- A soil structure analysis/grade analysis should be conducted as outlined in Appendix 15 or by a soils laboratory
- The resulting soil texture and structure (shape and grade) as well as the infiltration loading rate, slope of the site, and distance to a restrictive layer should be used to determine the width and area of a system according to the "Effluent Soil Loading Rates and Linear Loading Rates" table in Appendix 15.

Note: A soil percolation test or soil texture classification method may be the only acceptable method depending on the location of the system and the policy of the local municipality and/or health region.

- The mound must be sized to accommodate loading placed on the system. Dwellings with high water usage should design their mounds larger to prevent overloading and mound failure/breakout.
- The graded stone should be clean/washed and of a size ranging from 10 mm – 70 mm (0.5 in– 3 in).
- The perforated distribution pipe should be 100 mm (4 in) in diameter, and made of a material approved by the local health region with ends capped.
- A plastic or concrete distribution box must be used.
- The layer of graded stone should be a minimum of:
 - 300 mm (12 in) below the perforated pipe;
 - 150 mm (6 in) to cover the perforated pipe.
- The native soil should be removed to a depth of between 150 mm (6 in) and 300 mm (12 in).
- A landscape fabric should be placed above the final layer of graded stone to stop soils from penetrating into the stone layer, which could plug the mound resulting in failure.
- The graded stone should be extended at least 1 m (3 ft) past the ends of the perforated pipe.
- The graded stone should be covered with straw to a depth of 150 mm – 500 mm (6 in – 20 in).

- ❑ The straw and slopes of the mound should be covered with 150 mm – 200 mm (6 in – 8 in) of topsoil.
- ❑ The slopes of the mound should be approximately 1 vertical to 3 horizontal. The toe lengths of greater than 1.35 m (4.5 ft) are based on beginning the stone layer 150 mm (6 in) below grade.
- ❑ The Type I mound shown in Figures 9.2 and 9.3 is the preferred option. The mound shown in 9.4 and 9.5 should only be used for special cases approved by the local authority.
- ❑ The Type I mound examples shown are level sites.
- ❑ The Effective Absorption Width (A) of the preferred Type I mound is recommended to be no wider than 3 m (10ft).

Figure 9.2 Type I Mound Plan View

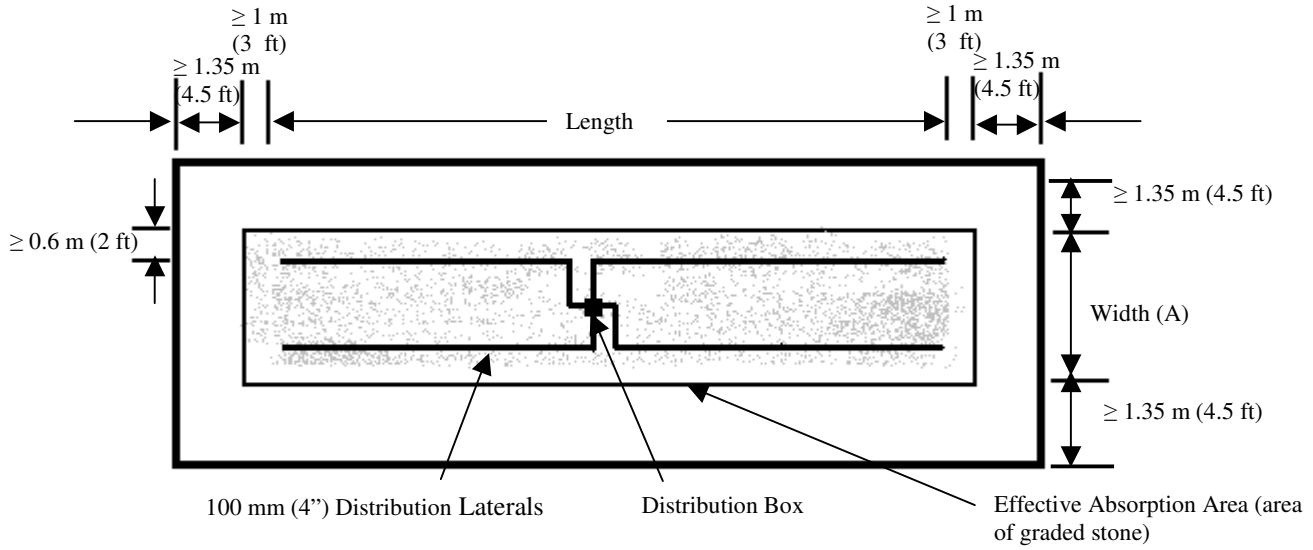
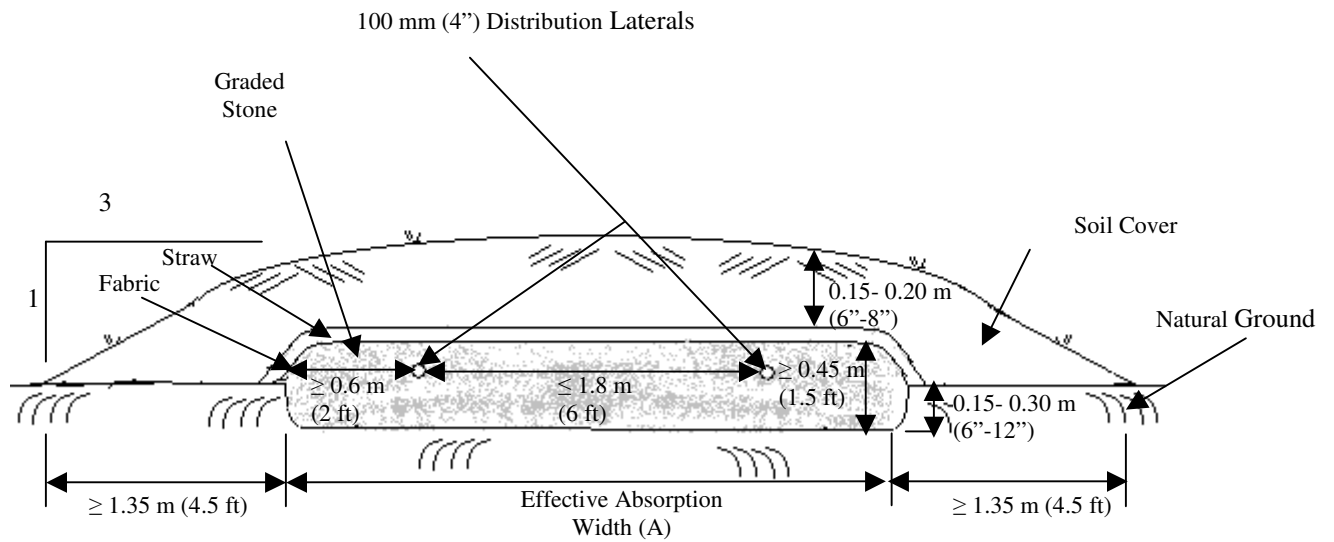

Figure 9.3 Type I Mound Side View



Special Case: Type I Mound for Small Systems

For special cases where the installer believes that this Type I mound will perform adequately and where approved by the local authority, the following design criteria can be used to make a circular type I mound.

The Type I Mound should be designed so that:

- For a three bedroom house, the dimensions of this Type I mound may be:
 - Where native soil is loamy sand:
 - Area: 50 m² (534ft²);
 - Total Diameter: 8.0 m (26 ft);
 - Length of each of the 10 laterals: 2.75 m (9 ft);
 - Minimum volume of graded stone: 23 m³ (800 ft³).
 - Where native soil is sandy loam:
 - Area: 69.7 m² (750 ft²);
 - Total Diameter: 9.4 m (30.9 ft);
 - Length of each of the 10 laterals: 3.5 m (11.45 ft);
 - Minimum volume of graded stone: 31.9 m³ (1125 ft³).
 - Where native soil is loam:
 - Area: 89.6 m² (964 ft²);
 - Total Diameter: 10.7 m (35 ft);
 - Length of each of the 10 laterals: 4.1 m (13.5 ft);
 - Minimum volume of graded stone: 41 m³ (1446 ft³).
 - Where native soil is silt loam or sandy clay loam:
 - Area: 112 m² (1205 ft²);
 - Total Diameter: 12 m (39.2 ft);
 - Length of each of the 10 laterals: 4.75 m (15.6 ft);
 - Minimum volume of graded stone: 51.2 m³ (1808 ft³).
 - Where native soil is silt:
 - Area: 125.4 m² (1350 ft²);
 - Total Diameter: 12.6 m (41.5 ft);
 - Length of each of the 10 laterals: 5.1 m (16.7 ft);
 - Minimum volume of graded stone: 57.3 m³ (2025 ft³).
 - Where native soil is clay loam:
 - Area: 142.5 m² (1534 ft²);
 - Total Diameter: 13.5 m (44.2 ft);
 - Length of each of the 10 laterals: 5.5 m (18.1 ft);
 - Minimum volume of graded stone: 65 m³ (2300 ft³).
- For systems serving buildings other than three bedroom residences, Appendix 7A can be used for assistance.

- ❑ The layer of graded stone should be a minimum of:
 - 300 mm (12 in) below the perforated pipe;
 - 150 mm (6 in) to cover the perforated pipe.
- ❑ The graded stone should be clean/washed and of a size ranging from 10 mm – 70 mm (0.5 in – 3 in).
- ❑ The perforated distribution pipe should be 100 mm (4 in) in diameter, made of a material approved by the local health region, with ends capped.
- ❑ The graded stone should be extended at least 1 m (3 ft) past the ends of the perforated pipe.
- ❑ A plastic or concrete distribution box must be used. A box 0.6 m by 0.6 m (2 ft by 2 ft) is used for the purposes of determining the lateral length. If a different size of distribution box is used, the lateral length should be adjusted.
- ❑ A landscape fabric should be placed above the final layer of graded stone to stop soils from penetrating into the stone layer, which could plug the mound resulting in failure.
- ❑ The graded stone should be covered with straw to a depth of 150 mm – 500 mm (6 in – 20 in).
- ❑ The straw and slopes of the mound should be covered with 150 mm – 200 mm (6 in – 8 in) of topsoil.
- ❑ The slopes of the mound should be approximately 1 vertical to 3 horizontal.

Figure 9.4 Alternative Type I Mound

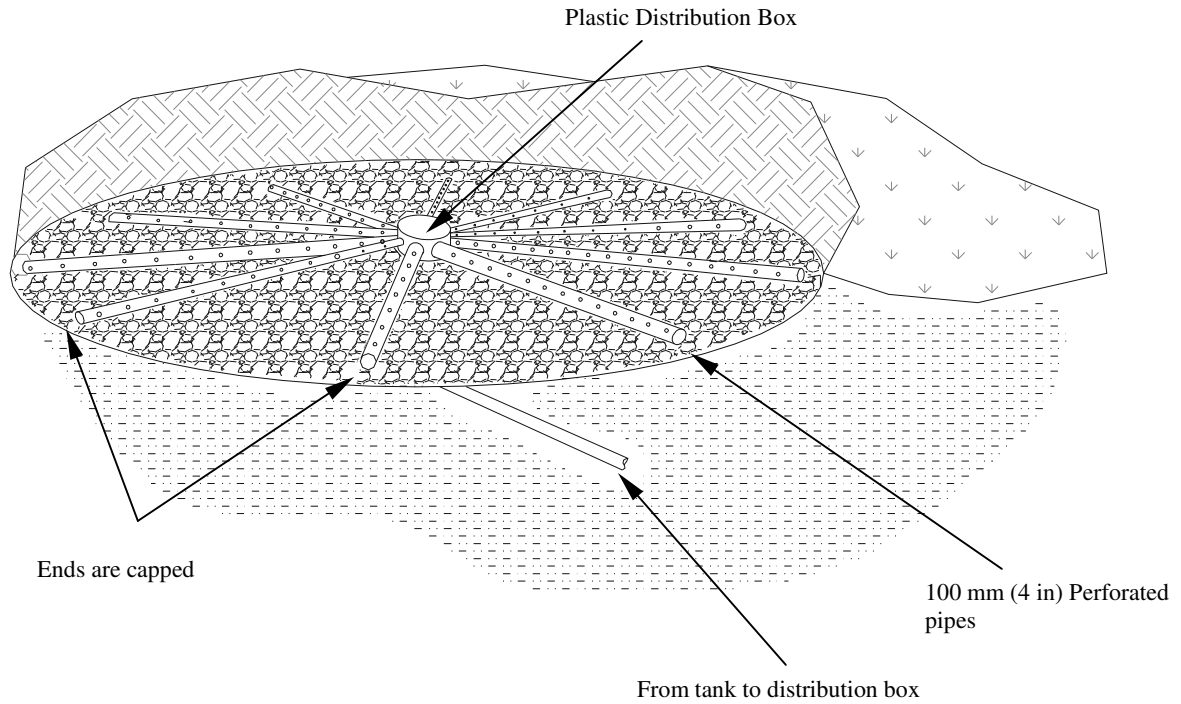
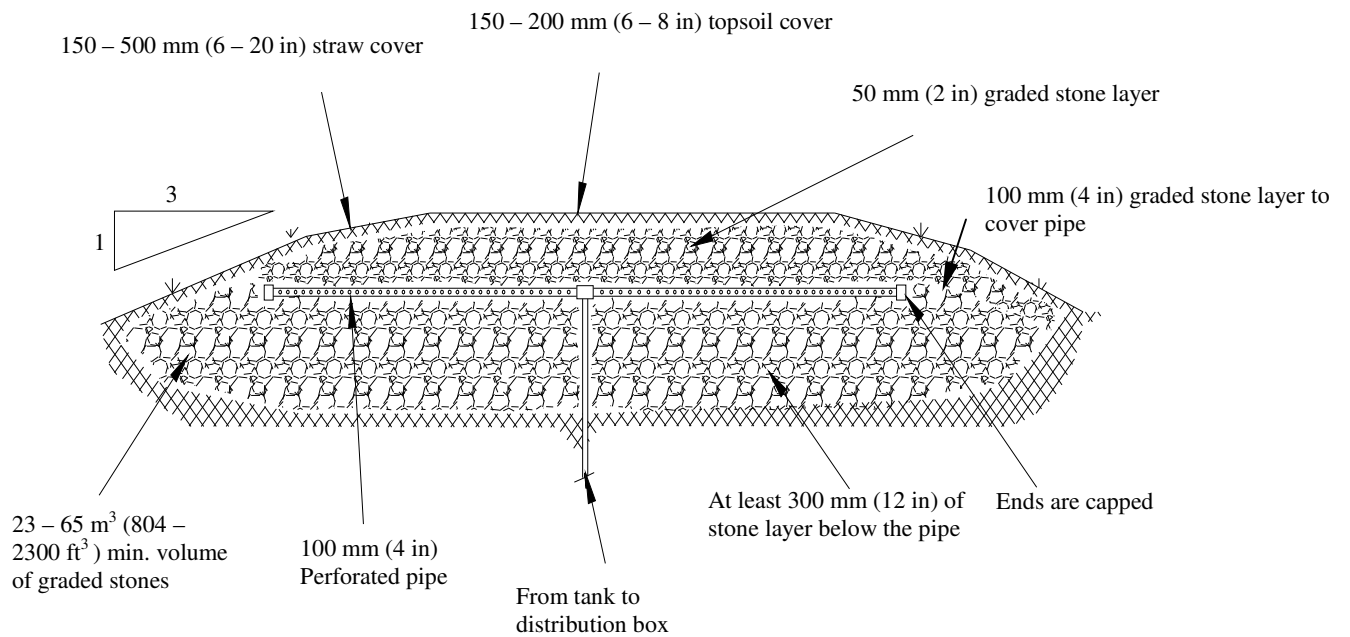

Figure 9.5 – Alternative Type I Mound Cross Section

(Note: This figure depicts a cross section of the alternative Type I Mound. Please refer to Figure 9.4 which illustrates the layout of the distribution box and laterals).



9.1.4 INSTALLATION

9.1.4.1 Site Solution

If considering a mound, it is important to maintain the horizontal separation distances from water supply wells, surface waters, springs, cuts, the boundary of the property, and the building foundation. Mounds should not be constructed in flood plains, drainage ways, or depressions unless flood protection is provided.

9.1.4.2 Soil Depth

The mound system should be located so as not to impact on the water table. As a general guide to local authorities and installers, all Health Regions in Saskatchewan view 1.5 m (5 ft) as an appropriate minimum vertical separation between the infiltration surface and the water table. As well, in the case of *The Shoreland Pollution Control Regulations, 1976* require a 1.5 m (5 ft) separation if the soil is clay and 7.6 m (25 ft) if sand. If a contractor is in doubt as to what would be considered an appropriate separation, they are strongly urged to contact the local health region before installation.

9.1.4.3 Setback Requirements

A mound system, measured from the point where the side slope of the mound intersects with the natural soil contour, shall have a minimum setback distance as follows:

<input type="checkbox"/> Building	9 m (30 ft)
<input type="checkbox"/> Recreation Areas	60 m (200 ft)
<input type="checkbox"/> Property Boundary	3 m (10 ft)
<input type="checkbox"/> Walk/Driveway	1.5 m (5 ft)
<input type="checkbox"/> Cut or embankment	3 m (10 ft)
<input type="checkbox"/> Ground water table	1.5 m (5 ft)
<input type="checkbox"/> Well*	15 m (50 ft)
<input type="checkbox"/> Water Course	15 m (50 ft)

* Unless otherwise approved by the local authority (through consultation with Saskatchewan Ministry of Environment officials), the setback distance from a well that is used as a water source for a municipal waterworks should be at least 75 m (250 ft) in the case of a small municipality (less than 1,000 population) and at least 225 m (750 ft) in the case of a large municipality (1,000 or more population).

A Type I Mound is to be installed only on a parcel/lot having an area greater than 465 m² (5000 ft²).

When mounds are located on slopes, a diversion shall be constructed immediately up slope from the base of the mound to intercept and direct run-off water away from the mound.

9.1.4.4 Inspection

Before the system is covered the local health region shall be contacted to request an inspection. A Public Health Inspector with the local health region may inspect the installation or provide approval to proceed with the covering of the system.

9.1.5 CARE AND MAINTENANCE

Like other systems, poor maintenance could lead to early system failure. If mounds are improperly designed or constructed, the following problems can occur:

- ❑ Clogging of part or all of the distribution system.
- ❑ Seepage out of the mound.
- ❑ Spongy areas on the side or top of the mound.
- ❑ Ponding of effluent in the mound, resulting in system overload and failure.

To minimize the risk of system failure:

- ❑ Divert all surface runoff away from the mound.
- ❑ Timed dosing regularly throughout the day.
- ❑ Install water-saving devices on fixtures to prevent system overload.
- ❑ Keep all traffic off the mound.
- ❑ Keep shrubs and trees off the mound.
- ❑ Plant grass on the mound surface to prevent erosion.

In order to protect from freezing the mound is kept covered during the winter months with:

- ❑ at least 0.5 m (1.7 ft) of snow; or
- ❑ when there is inadequate snow cover, the use of straw bales.

Grass cover should be established over the entire area and no shrubs should be planted on the top of the mound.

9.2 TYPE II MOUNDS

9.2.1 DEFINITION

Mounds are an excellent treatment and disposal choice, however, it cannot be overemphasized that careful planning and design, filter media selection, construction and maintenance of the mound is critical. Mound systems require an environment for microbial activity so care in the material selection and construction steps must be taken to provide such an environment.

This mound is a wastewater treatment system that is raised above the natural soil surface in a specific graded, clean sand media. Perforated laterals under pressure receive wastewater effluent from a septic tank. These laterals distribute the effluent over a gravel bed and sand media. The sand layer is overlain with a gravel layer or chambers to assist in the distribution of the effluent over the entire surface of the sand layer and provide a brief storage layer for the effluent as it is pumped onto the mound. The covering soil, loamy sand, must be porous to provide good aerobic conditions in the sand layer. Using a clay soil for covering material would limit air movement into the mound causing anaerobic conditions and greatly reduce the effectiveness of the sand layer.

Figure 9.4 Type II Mound

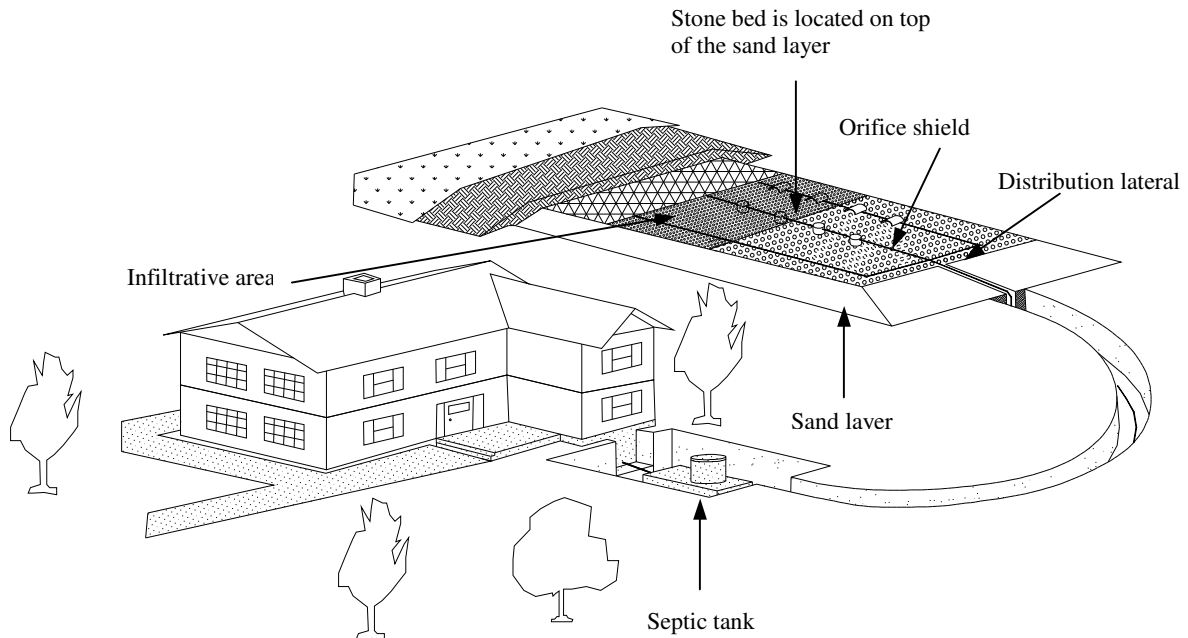

9.2.2 FUNCTION

Sewage mounds have two key functions: to dispose of effluent from the septic tanks and to distribute this effluent in a manner allowing adequate natural wastewater treatment in the sand bed and natural soil before the effluent reaches the underlying groundwater.

Sewage effluent is pumped from the septic tank to the distribution laterals under pressure. Effluent in the laterals is spread over the gravel and sand and allowed to percolate through this layer removing the organic load in the effluent. The effluent undergoes biological treatment as it passes through the different layers of gravel, sand and soil to the natural environment. The mound treatment produces an effluent that is equivalent or better than other conventional onsite disposal systems.

Type II Mounds offer a possible solution to difficult soil conditions or other site restrictions such as a high water table. If the soil percolation rate is either too fast or too slow or a seasonally saturated soil or water table exists closer than 900 mm (3 ft) from the surface, construction of a Type II mound may be an option.

9.2.3 DESIGN

To ensure proper performance of the mound system, the following concepts must be included in the design and construction process:

- ❑ Quality of clean sand fill
- ❑ Size and shape (infiltrative area)
- ❑ Soil surface preparation
- ❑ Construction procedures (leaving the topsoil in place but plowing it before placement of the fill)
- ❑ Distribution of effluent
- ❑ Dosing quantity
- ❑ Location

It is also recommended that track type machinery should be used to move the sand into place and at least 150 mm (6 in) of sand should be kept beneath the machinery to minimize compaction of the soil under the sand layer to prevent smearing or glazing of the soil under the mound area.

All piping used in or in conjunction with a mound system must be of a type that is acceptable to the local health region. A vertical separation of at least 900 mm (3 ft) is required between the sand layer and any restricting layer or seasonally saturated layer in order to maintain aerobic conditions in the natural fill soil under the gravel bed. However, 1.5 m (5 ft) may provide an additional treatment capacity and increase the probability of long term success.

The Type II Mound may be constructed on most soil types provided that the percolation rate in:

- ❑ The natural or fill soil is faster than 120 minutes per 25 mm (1 in) to a depth of at least 600 mm (2 ft) below the sand layer.

- ❑ Below the sand layer there is a layer of soil at least 300 mm (1 ft) thick, that has a percolation rate slower than five minutes per 25 mm (1 in).

The sand layer shall have a surface area designed on the basis of not more than 50 L of effluent per square meter (1 gal per sq ft) per day loading rate. **The sand layer shall be no less than 37 square metres (400 sq ft) and must be 3 m (10 ft) wide or less.** Making the sand layer narrower than 3 m (10 ft) and longer can provide a better working and more effective mound.

The top of the sand layer, upon which the stone bed is located, is on or above the existing soil and is level. Type II Mounds may be constructed with the contact area between the gravel or chambers and the sand layer less than 3 m (10 ft) wide. When a longer narrower mound is desired, the number of distribution laterals can be reduced from 3 to 2. A Type II Mound with only 2 distribution laterals would have a maximum width of the contact area between the gravel, or chambers, and the sand layer of 2 m (6.5 ft).

The sand layer below the stone bed has a minimum depth of:

- ❑ 1500 mm (5 ft) where the soil below the sand bed is **near** impervious;
- ❑ 900 mm (3 ft) where the sand overlays a seasonal saturated level; or
- ❑ 300 mm (1 ft) in any other case.

The area of the mound within the berm, excluding the end slopes, providing the infiltration area into the original soil should be constructed of a loamy sand or sandy loam fill material.

The distribution of effluent into the sand layer should be into:

- ❑ a layer of gravel over the sand layer, or
- ❑ chambers that provide an infiltrative area that is not less than 80% the designed area of the sand layer receiving the effluent.

When Chambers are used:

- ❑ the sand layer should be covered with a minimum of 50 mm (2 in) of gravel,
- ❑ a pressure effluent distribution lateral on top of the gravel should be provided for each row of chambers.

Materials used for Type II mounds:

- ❑ Sand used for the sand layer should be a soil texture composed by weight of at least 85% soil particles varying in size from 2.0 mm to 0.05 mm, and containing not more than 10% fines.
- ❑ Gravel for the stone bed should be of a size ranging from 12 mm (1/2 in) – 40 mm (1 1/2 in) particle size containing not more than 5% fines, silt or clay.

Additional recommendations include the following:

- ❑ The layer of graded stone placed over the sand layer:

- below the laterals is to be not less than 225 mm (9 in);
 - above the laterals is to be not less than 50 mm (2 in).
- ❑ There is a layer of straw placed over the stone bed material to a non-compacted depth of 75 – 100 mm (3 in – 4 in) to prevent migration of soil into the gravel; filter fabric may also be used in place of the straw. It should be noted that some chamber manufacturers require filter fabric to be installed over the chambers, while others do not (check manufacturer specs).
 - ❑ Sandy loam material should be placed over the gravel layer to a depth of 300 mm (12 in) in the center of the mound and to a depth of 150 mm (6 in) at the sides.
 - ❑ Topsoil should be placed to a minimum depth of 75 mm (3 in) over the entire area of the mound.
 - ❑ The side slopes on the mound should not be steeper than 1:4 (one vertical to four horizontal).

Figure 9.5 – Chamber Mound

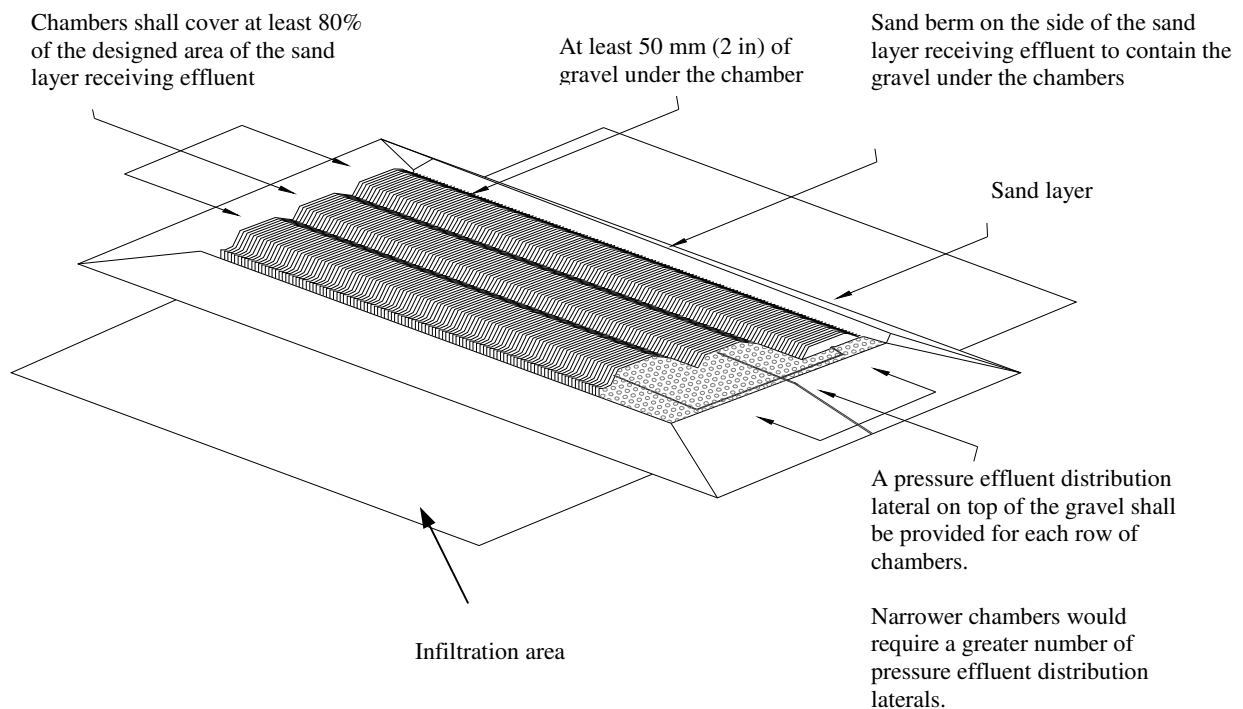

The quantity of effluent delivered to the mound per pump cycle should not exceed 25% of the estimated or measured daily sewage flow. Smaller doses provide better treatment conditions. The amount of effluent to be delivered per dose should be set with the pump on/off floats or controls to match the system design.

To illustrate this, an example would be the maximum dose delivered to a mound is 25% of the daily volume (See Appendix 2). For a 3-bedroom house, the single dose is calculated as $337.5 \div 4 = 84$ gals. The maximum amount delivered to the mound in each dose would be 84 gals. To achieve the maximum dose, the pump controls need to be set in the effluent chamber to deliver $84 \div 6.25$ (gals per cubic foot) = 13.4 ft³ of effluent + the amount needed to fill the distribution line and laterals.

The following table provides information on liquid volume of various sizes of plastic pipes:

Nominal Pipe Diameter	Inside Diameter		Volume (per 100 feet of pipe)	
	mm	inches	Litres	Imp Gallons
1	26.65	1.049	17	3.74
1 ¼	31.10	1.380	30	6.48
1 ½	40.89	1.61	40	8.82
2	52.5	2.067	66	14.66
3	77.93	3.068	145	30
4	102.26	4.026	250	55.1

If the effluent chamber is 2 ft by 4 ft = 8 ft² the calculation is 13.4 ft³ total \div 8 per foot of drop = a draw down of 1.675 ft to provide the 84 gals of effluent, not including the amount for the piping.

In large systems where the effluent volume available is not sufficient to dose the entire system, it may be desirable to split the system into sections and dose these sections sequentially. This also reduces pumping requirements and pipe sizes.

Distribution of effluent shall be by distribution laterals under pressure. Gravity distribution of effluent in a Type II Mound is not permitted. Distribution of effluent should be by perforated pipe, under pressure from a manifold. Pipe perforations should be drilled straight into the pipe and not at an angle; the maximum number of orifices in distribution laterals should be in accordance with Appendix 4.

Pipe orifices are located in the distribution laterals:

- ❑ to direct the spray in a direction that will not cause erosion of the soil or sand layer, and
- ❑ be provided with a device that will deflect the spray to prevent erosion of the soil above and the entry of foreign material into the orifice if the orifice is pointed upwards.

The effluent pump rate of discharge should be designed to evenly deliver effluent to the mound while maintaining head pressure in accordance with Appendix 5. The minimum head pressure is measured at the farthest point of the distribution manifold. Head pressure required in the distribution laterals is a minimum 600 mm (2 ft) head for mounds. Remember to consider pressure loss in effluent line to the treatment line. See Appendix 6 for friction loss in the effluent line between the septic tank and the mound.

The rate of discharge per orifice diameter and pressure head should be calculated as specified in Appendix 5.

Pipe orifices need to be sized to provide relatively even distribution of effluent over the sand layer, as per Appendix 12.

When distribution laterals are installed in gravel, pointing the orifices down will not erode the sand layer. However, there is a greater possibility of orifice clogging and slightly uneven distribution of effluent. If the orifices are pointed up, orifice shields must be provided to prevent gravel from lying on the orifice and restricting the flow or erosion of the soil above. Also, greater care must be taken to ensure the distribution lateral is graded to allow drainage. A few orifices can be drilled to point down to allow for drainage of the pipe. If the distribution laterals are installed inside a chamber, the orifices should be pointed up to prevent erosion of the surface of the sand layer under the chamber.

9.2.3.1 Sizing The System

Proper sizing is key to ensuring the mound system meet's the landowner's needs, both current and future. How the mound is designed and constructed will determine the effectiveness of this type of system in handling the sewage volumes produced. Under-sizing a mound will result in certain failure of this type of system.

The size of the actual sand layer is determined by the expected daily volume of sewage. The sand layer that receives the effluent is sized at 1 gals/ft². For example, a 4 bedroom home at 2045 L (450 gals) per day load requires a sand layer area of 42 m² (450 ft²). The total area of the sand layer is sized on the basis of not receiving more than 50 L (11 gals) of effluent per m²/day. By determining the existence of any impermeable layer or saturated soil, one can determine the elevation of the sand layer. (See Figure 9.5)

The infiltration area of the mound is that area of soil covered by the mound and that receives effluent. The berms located at the ends of the mound are necessary for mound construction but the soil under these berms is not considered part of the total infiltrative area. To prevent seepage at the toe of the berm, the area of the soil receiving the effluent must be sized to absorb the expected loads.

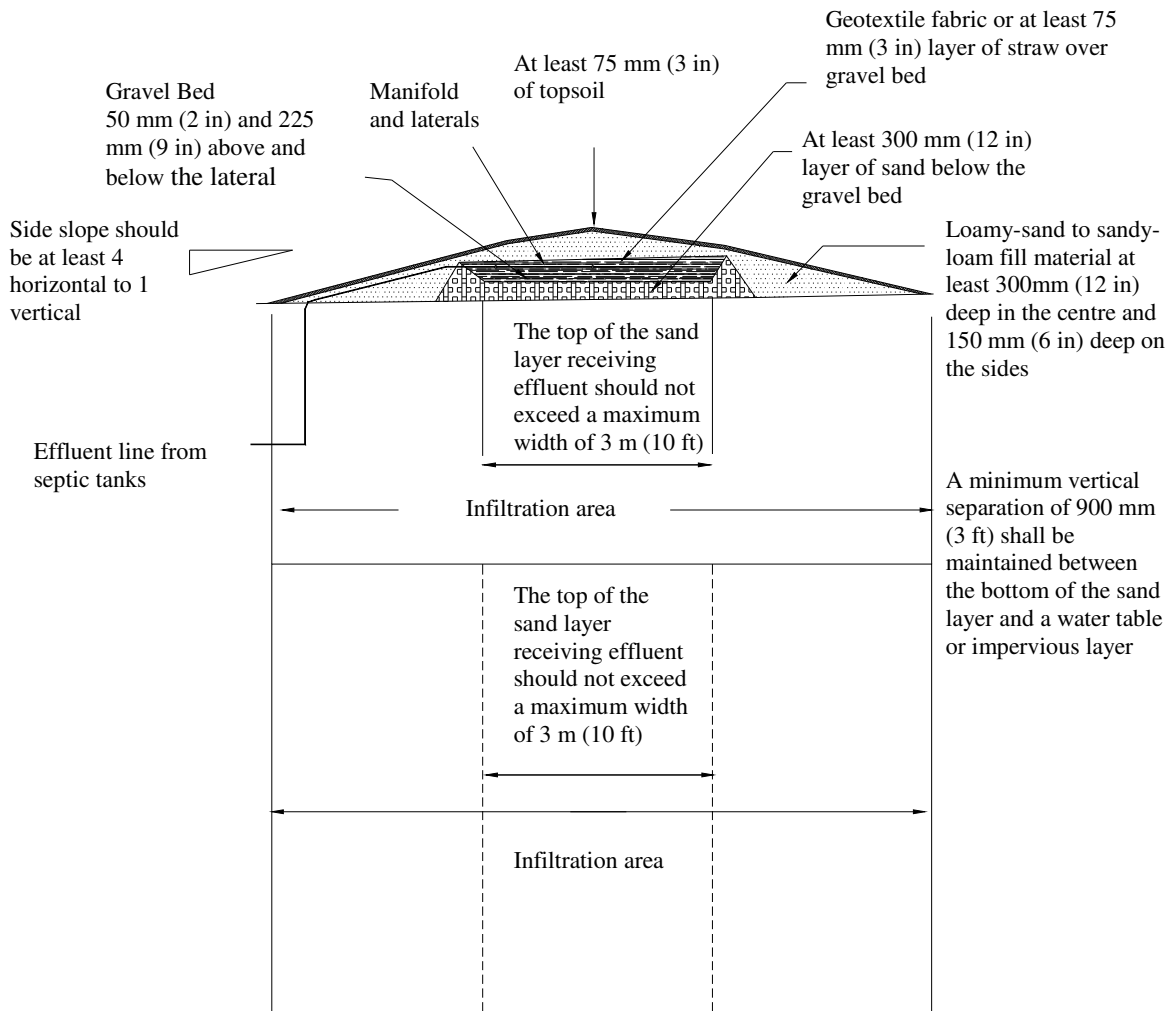
Figure 9.6 - Mound

The Type II Mound may be constructed on a natural slope provided that:

- ❑ The slope is less than 3% and the percolation rate is not slower than 60 minutes per 25 mm (1 in) to a depth of at least 600 mm (2 ft) below the sand layer;
- ❑ The slope is less than 6% and the percolation rate is not slower than 30 minutes per 25 mm (1 in) to a depth of at least 600 mm (2 ft) below the sand layer; and
- ❑ The slope does not exceed 12% regardless of percolation rate.

When mounds are located on slopes, a diversion shall be constructed immediately up slope from the base of the mound to intercept and direct run-off water away from the mound.

Figure 9.7 – Mound on slope

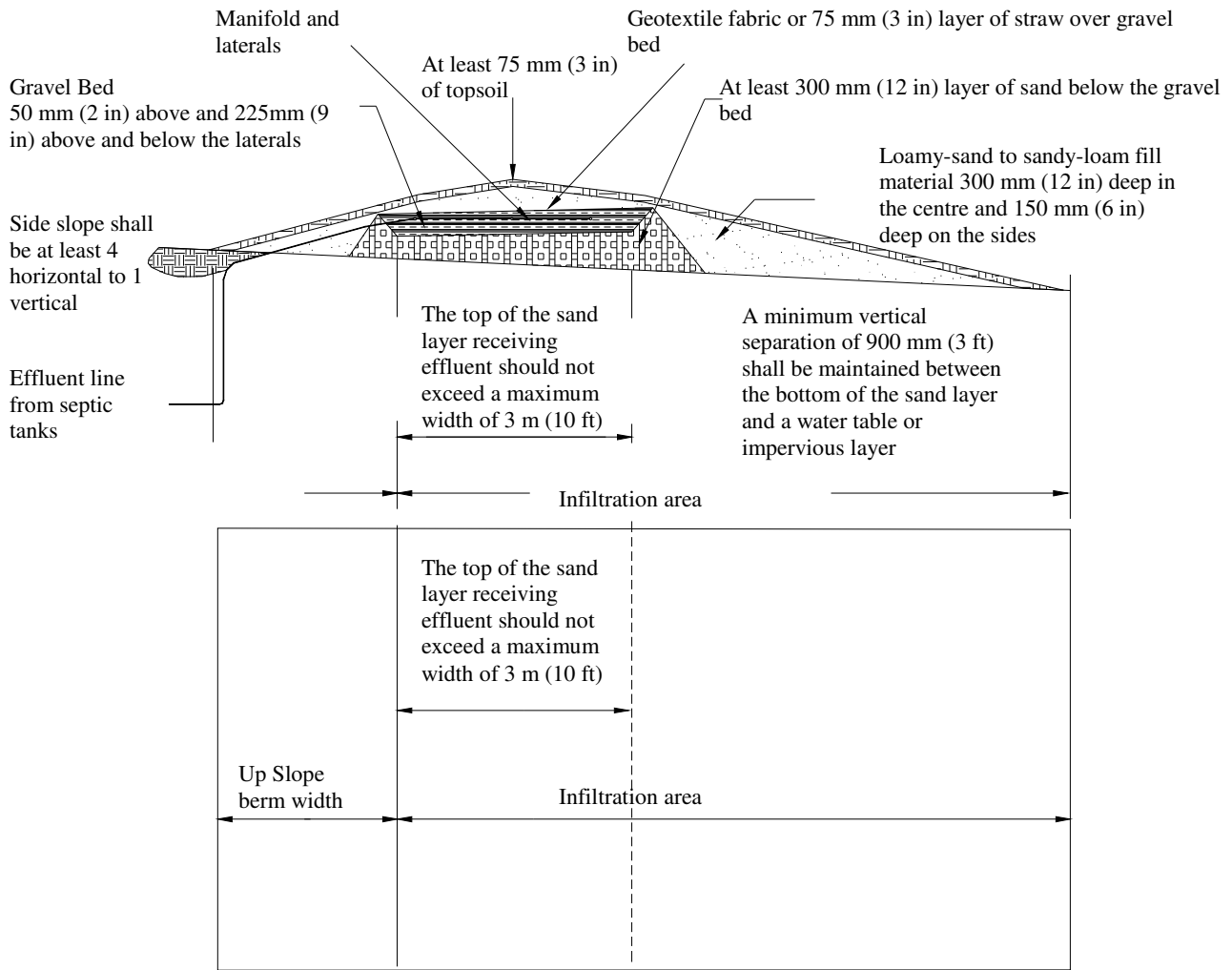

9.2.3.2 Calculating System Size Using Soil Percolation Test or Soil Texture Classification Method

In order to size a system, the daily ability of the soil to absorb moisture (field loading rate) and the daily volume of effluent need to be calculated. There are two ways to determine the field-loading rate: a percolation test or a soils analysis.

When a soil percolation test is conducted the percolation rate can be converted to a loading rate in liters per square meter or gallons per square foot using Appendix 1. The preferred way to determine a field-loading rate is to use the soil texture classification method to arrive at a rate that is also expressed in volume per area.

Soils determined to be "not suitable without further testing" as outlined in Appendix 15, pg. A-41, will require further analysis. Additional information is required in order to determine if a narrower, longer sand layer in a type II mound is an option for adequate treatment of wastewater.

- A soil structure analysis/grade analysis should be conducted as outlined in Appendix 15 or by a soils laboratory
- The resulting soil texture and structure (shape and grade) as well as the infiltration loading rate, slope of the site, and distance to a restrictive layer should be used to determine the width and area of a system according to the "Effluent Soil Loading Rates and Linear Loading Rates" table in Appendix 15.

Note: A soil percolation test or soil texture classification method may be the only acceptable method depending on the location of the system and the policy of the local municipality and/or health region.

Appendix 1 or Appendix 2 can be used to estimate typical volumes for various occupancies.

When the absorption rate and the volume are known, Appendix 1 can be used to determine the total soil treatment area required. The total soil treatment areas in Appendix 1 are based on areas required for conventional tile field systems. The infiltrative area for mounds is sized at 70% of the size of the trench bottom area required for a disposal field calculated by using percolation tests or soil texture classification to establish a loading rate per square meter or square foot. No additional field size reductions for using secondary treated effluent or pressure distribution apply to Type II mounds. Loading rates according to soil texture classification can be found in Appendix 15 'Soil Tests'.

$$\frac{\text{Expected Volume of Sewage per Day}}{\text{Loading Rate of the Soil}} \times 0.7 = \text{Infiltrative Area}$$

Loading Rate of the Soil

The Type II Mound Worksheet (Appendix 7) can be used as an aid in calculations to determine the required infiltrative area under the mound.

Examples of Systems Designed for Three-Bedroom Homes in Different Soil Conditions:

The daily sewage volume in each case is estimated to be 1530 L (337.5 gals). Appendix 1 is used to determine size of system.

- **Loamy Sand Soil** (It is assumed that the soil has a percolation rate of 7)

3 bedroom house effluent volume: 1530 L (337.5 gals) per day

Soil loading rate: 30.82 L/m² (0.64 gals/ft²)

$$\begin{aligned}
 \text{Infiltrative Area} &= \frac{\text{Expected Volume of Sewage per Day L (gals)}}{\text{Loading Rate of the Soil L/m}^2 \text{ (gals/ft}^2\text{)}} \times 0.7 \\
 &= \frac{1530 \text{ L (337.5 gals)}}{30.82 \text{ L/m}^2 \text{ (0.64 gals/ft}^2\text{)}} \times 0.7 \\
 &= 49.6 \text{ m}^2 \text{ (527.3 ft}^2\text{)} \times 0.7 \\
 &= \mathbf{34.7 \text{ m}^2 \text{ (370 ft}^2\text{)}}
 \end{aligned}$$

Remember the sand layer shall be no less than 37 square metres (400 ft²), so this system would be sized at 400 ft².

- **Silt Soil**

It is assumed that the soil has a percolation rate of 35 which equals a loading rate of 13.78 L/m² (0.28 gals/ft²). In these conditions, the infiltrative area of 77.7 m² (843.7 ft²) is required.

- **Clay Loam Soil**

It is assumed that the soil has a percolation rate of 58 which equals a loading rate of 10.71 L/m² (0.22 gals/ft²). In these conditions, an infiltrative area of 100 m² (1073.8 ft²) is required.

9.2.3.3 Pressure Distribution Lateral Design

Pressure distribution laterals are essentially rigid plastic pipe having evenly spaced holes drilled in the pipe out of which the effluent will spray. Pressure distribution laterals must be custom made for each individual installation. The intent of a pressure distribution lateral system is to provide for the even distribution of effluent over the entire surface of the treatment area. This assures the entire design is used equally and prevents localized overloading.

The distribution laterals should be:

- Connected to a manifold pipe with all ends capped. The manifold pipe shall be connected to the pump discharge pipe and shall slope back towards the pump.
- Spaced not less than 900 mm (36 in) and not more than 1000 mm (40 in) on center.
- Located not less than 400 mm (16 in) or more than 500 mm (20 in) from the edge of the gravel layer.
- Sized in accordance with Appendix 4.

Pressure distribution laterals for a mound are usually constructed of PVC plastic piping not smaller than 19 mm (3/4 in) or larger than 50 mm (2 in). The orifices to be drilled into each lateral are not smaller than 3.2 mm (1/8 in). The size and spacing of the perforations is dependant upon the length of the lateral (as determined in Appendix 4), and the amount of effluent to be discharged in a specific period of time, depending on pump head pressure (as determined in Appendix 5). Maximum orifice spacing for mounds is 1.5 m (5 ft), however a good target is one orifice for every 0.5 m² (6 ft²). The effluent pump must be provided with a suitable screen to prevent smaller particles from being discharged into the system and causing plugging or the orifices.

Appendix 17, Pressure Distribution: Orifice, Pipe and Pump Sizing Worksheet should be followed to size the piping and pump requirements for a pressure distribution lateral system. The following information should be determined and available:

- ❑ The spacing, size, total number of orifices and design pressure head proposed for the install.
- ❑ The vertical head from the elevation of the pump to the distribution system, identify differences in elevation between laterals, if any.
- ❑ The length of the effluent line and number of fittings from the pump to the distribution header to determine the friction loss in the piping.
- ❑ The required length of the distribution laterals.
- ❑ The volume of pump discharge at various head pressures (pump curve chart) for the model of pumps available (a siphon cannot be used). Volumes may have to be converted to imperial measures.
- ❑ Volume of effluent available in effluent chamber and desired duration of pumping or dosing cycle.

9.2.4 INSTALLATION

9.2.4.1 Site Selection

If considering a mound, it is important to maintain the horizontal separation distances from water supply wells, surface waters, springs, cuts, the boundary of the property, and the building foundation. Mounds should not be constructed in flood plains, drainage ways, or depressions unless flood protection is provided.

9.2.4.2 Soil Depth

The mound system should be located so as not to impact on the water table. As a general guide to local authorities and installers, all health regions in Saskatchewan view 1.5 m (5 ft) as an appropriate minimum vertical separation. As well, in the case of mounds, *The Shoreland Pollution Control Regulations, 1976* require a 1.5 m (5 ft) separation if the soil is clay and 7.6 m (25 ft) if sand. If a contractor is in doubt as to what would be considered an appropriate separation, they are strongly urged to contact the local health region before installation.

Mound construction begins by establishing the presence of an impermeable layer or soil mottling. This is accomplished by excavating test holes. By determining the depth to any impermeable layer or saturated soil determines the required elevation of the sand layer. The size of the sand layer is determined by the expected daily volume of sewage (Appendix 2). The sand layer for a mound is sized at 4.5 L (1 gal) of effluent per day per square foot.

9.2.4.3 Setback Requirements

A mound system, measured from the point where the side slope of the mound intersects with the natural soil contour, shall have a minimum setback distance as follows:

<input type="checkbox"/> Building	9 m (30 ft)
<input type="checkbox"/> Recreation Areas	60 m (200 ft)
<input type="checkbox"/> Property Boundary	3 m (10 ft)
<input type="checkbox"/> Walk/Driveway	1.5 m (5 ft)
<input type="checkbox"/> Cut or embankment	3 m (10 ft)
<input type="checkbox"/> Ground water table	1.5 m (5 ft)
<input type="checkbox"/> Well*	15 m (50 ft)
<input type="checkbox"/> Water Course	15 m (50 ft)

Mounds that are permitted within a shoreland development area, as defined by The Shoreland Pollution Regulations, 1976, shall also meet the setback distances that are outlined within such regulations.

* Unless otherwise approved by the local authority (through consultation with Saskatchewan Ministry of Environment officials), the setback distance from a well that is used as a water source for a municipal waterworks should be at least 75 m (250 ft) in the case of a small municipality (less than 1,000 population) and at least 225 m (750 ft) in the case of a large municipality (1,000 or more population).

9.2.4.4 Inspection

Before the system is covered the local health region shall be contacted to request an inspection. A Public Health Inspector with the local health region may inspect the installation or provide approval to proceed with the covering of the system.

9.2.5 CARE AND MAINTENANCE

Like other systems, poor maintenance could lead to early system failure. If mounds are improperly designed or constructed, the following problems can occur:

- ❑ Clogging of part or all of the distribution system.
- ❑ Seepage out of the side of the mound.
- ❑ Spongy areas on the side or top of the mound.
- ❑ Ponding of effluent in the mound, resulting in system overload and failure.

To minimize the risk of system failure:

- ❑ Divert all surface runoff away from the mound.
- ❑ Time dose regularly throughout the day.
- ❑ Install water-saving devices on fixtures to prevent system overload.
- ❑ Keep all traffic off the mound.
- ❑ Keep shrubs and trees off the mound.
- ❑ Plant grass on the mound surface to prevent erosion.

In order to protect from freezing the mound is kept covered during the winter months with:

- ❑ at least 0.5 m (1.7 ft) of snow; or
- ❑ when there is inadequate snow cover, the use of straw bales.

Ensure there is grass cover over the entire area and **no** shrubs are planted on the top of the mound.

10.1 DEFINITION

A jet type disposal system is an open discharge method of sewage disposal. Effluent from a septic tank is pumped by a sewage pump through a pipe to a location where the effluent is discharged into the air and onto the ground surface. (See Figure 10.1 or 10.2)

10.2 FUNCTION

The wastewater in jet spray systems is applied at relatively low rates to grassy or wooded areas. Vegetation and soil microorganisms metabolize most nutrients and organic compounds in the wastewater during percolation through the first several inches of soil. The cleaned water is then absorbed by deep-rooted vegetation, or it passes through the soil to the ground water.

10.3 DESIGN

There are 2 basic versions of jet disposal systems utilized in Saskatchewan. The first system is the Jet Ejector System (see figure 10.1) and the second is the Surface Discharge System (see figure 10.2). A piping used in or in conjunction with a jet type disposal system must be of a type that is acceptable to the local health region.

10.3.1 Ejector System

This system is the more recommended method of open discharge disposal. In this method, effluent from the septic tank is pumped through a pipe to a location where the effluent is discharged into the air and onto the ground surface.

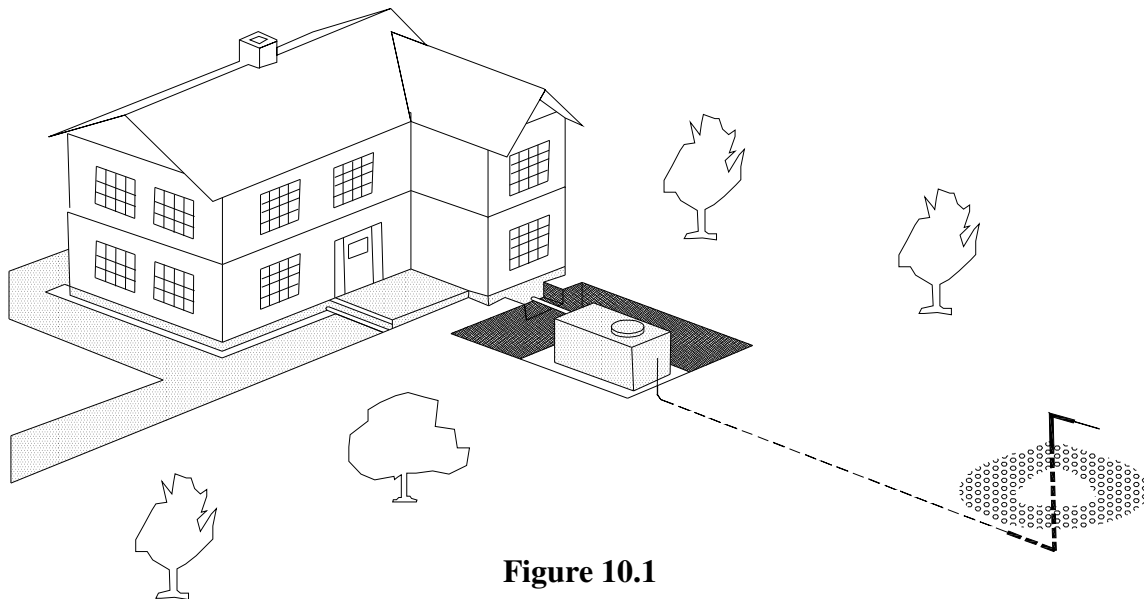

Figure 10.1

The overall efficiency of a jet spray system will be a function of the pollutant removal efficiencies of the entire treatment process especially the percolation rate of the soil and vegetation uptake. A number of items should be considered in the design including:

- ❑ The jet outlet should be higher, 1.8 m (6 ft) minimum, above piping at the septic tank. This will cause the effluent to drain back to the septic tank from the riser and prevent freezing of the effluent in the riser.
- ❑ A screening mechanism may be necessary, before the pump uptake, to prevent pump damage and plugging of the effluent line.
- ❑ A 1.2 m (4 ft) high (minimum) mound around the jet outlet to prevent erosion and provide some frost protection is recommended.
- ❑ A 1.5 m (5 ft) fence around the perimeter of the effluent outfall area is highly recommended. This will restrict access of pests, pets, farm animals, and children.
- ❑ Covering the mound of soil with fieldstone to prevent erosion from falling effluent is recommended.
- ❑ Pipe of sufficient size to prevent excessive head pressure at the pump should be used.
- ❑ The volume of the effluent line should not exceed the volume of the effluent chamber.
- ❑ Because the sewage effluent line is always full, it must be installed below the frost level [i.e., minimum 1.8 m (6 ft)].
- ❑ It is recommended that jet type disposal systems be designed in soils within a minimum percolation rate of 5 L/min. and a maximum of 24 L/min.
- ❑ Revolve elbow 90° every 3 months to prevent soil saturation.

10.3.2 Surface Discharge System

This system is the least recommended method of open discharge disposal. Some jurisdictions may not allow this method, please check with your local health inspector prior to construction. In this method, effluent from the septic tank is pumped through a pipe to a location where the effluent is discharged directly onto the ground surface.

The overall efficiency of this system is similar to the jet ejector system; it will depend on the pollutant removal efficiencies of the entire treatment process especially the percolation rate. A number of items should be considered in the design including:

- ❑ The outlet pipe should be carefully graded so the pipe can drain back into the septic tank between pump cycles to prevent freezing.
- ❑ The effluent line is generally 32 mm (1½ in) to 50 mm (2 in) pipe.
- ❑ Fieldstone may be placed over and under the outlet pipe for physical protection of the pipe and to prevent erosion.
- ❑ Pipe of sufficient size to prevent excessive head pressure at the pump should be used.
- ❑ The volume of the effluent line should not exceed the volume of the effluent chamber.
- ❑ It is recommended that jet type disposal systems be designed in soils within a minimum percolation rate of 5 L/min. and a maximum of 24 L/min.
- ❑ A screening mechanism may be necessary, before the pump uptake, to prevent pump damage and plugging of the effluent line.

- ❑ A 1.5 m (5 ft) fence around the perimeter of the effluent out fall area is highly recommended. This will restrict access of pests, pets, farm animals, and children.

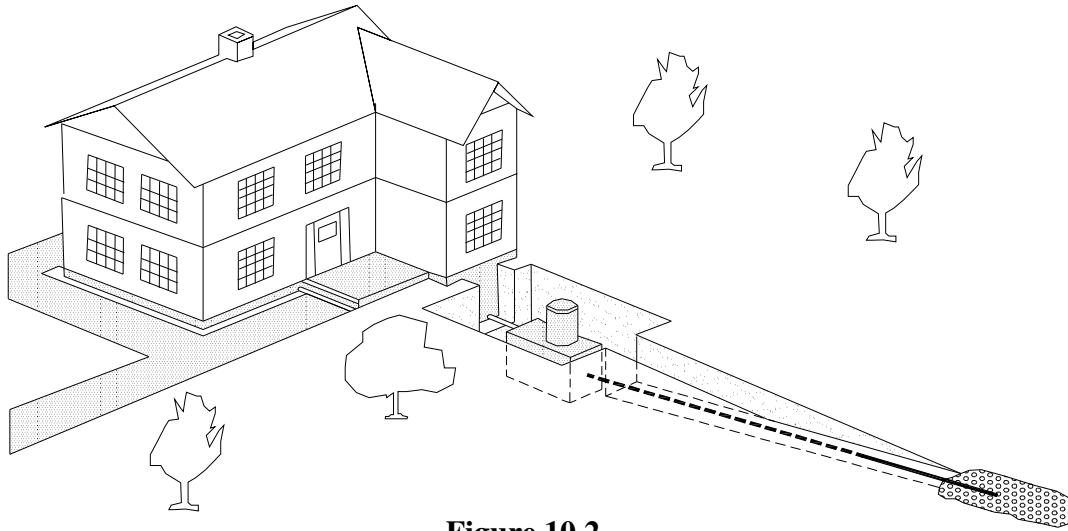

Figure 10.2

10.4 INSTALLATION

10.4.1 Site Selection

Drifting aerosols can be a nuisance and may impact on nearby land use and human contact. Unless otherwise approved by the local health region, jet type disposal systems should:

- ❑ serve not more than one dwelling unit located on a parcel/lot of land containing at least 4 ha;
- ❑ not be used for any commercial business such as a restaurant or any other which will generate volumes of effluent greater than that of a single family dwelling;
- ❑ not be installed in area that, in the opinion of the local health region, is considered to be a high density acreage area.

Jet type disposal systems should not be installed in flood plains, drainage ways or depressions unless flood protection is provided.

10.4.2 Setback Requirements

To minimize human exposure, large buffer areas are required. A jet type disposal system, measured from the point of discharge, shall have a minimum setback distance as follows:

- | | |
|--------------------------|-----------------|
| ❑ Building | 60 m (200 ft) |
| ❑ City, Town, or Village | 1 km (0.6 mile) |
| ❑ Recreation Areas | 60 m (200 ft) |

<input type="checkbox"/> Property Boundary	60 m (200 ft)
<input type="checkbox"/> Walk/Driveway	30 m (100 ft)
<input type="checkbox"/> Cut or embankment	30 m (100 ft)
<input type="checkbox"/> Ground water table	1.5 m (5 ft)
<input type="checkbox"/> Well*	45 m (150 ft)
<input type="checkbox"/> Water Course	45 m (150 ft)

* Unless otherwise approved by the local authority (through consultation with Saskatchewan Ministry of Environment officials), the setback distance from a well that is used as a water source for a municipal waterworks should be at least 75 m (250 ft) in the case of a small municipality (less than 1,000 population) and at least 225 m (750 ft) in the case of a large municipality (1,000 or more population).

NOTE: Point of discharge should not be onto:

- any ground surface that slopes towards a water source;
- any ground growing garden vegetables or animal forage crops or any area that is accessible to animals.

The jet type surface discharge system should be located so as not to impact on the water table. If a contractor is in doubt as to what would be considered an appropriate separation, they are strongly urged to contact the local health region before installation.

10.4.3 Inspection

Before the system is covered the local health region shall be contacted to request an inspection. A Public Health Inspector with the local health region may inspect the installation or provide approval to proceed with the covering of the system.

10.5 CARE AND MAINTENANCE

Construction factors include site preparation and installation of runoff controls, piping return systems, pumps, septic tank maintenance (see septic tanks) and storage facilities. Where storm water runoff can be significant, measures must be taken to prevent excessive erosion, including terracing of steep slopes, contour plowing, no-till farming, and establishment of grass border strips.

The soil profile must also be managed to maintain infiltration rates by avoiding soil compaction and maintaining soil chemical balance. Compaction and surface sealing (caused by motorized vehicles, heavy equipment and development of fine layers from multiple wastewater applications) can reduce soil infiltration and increase runoff.

11.1 DEFINITION

A lagoon is a shallow man-made artificial pond for the receiving, holding and treatment of sewage or effluent. The lagoon may be referred to as a “cell” or “lagoon cell”. Lagoons may be a single cell, operated in series or in parallel as a closed system, or form part of a disposal system where the treated effluent is eventually released or discharged.

Figure 11.1 Sewage Lagoon Installation
(Other designs may also be acceptable)

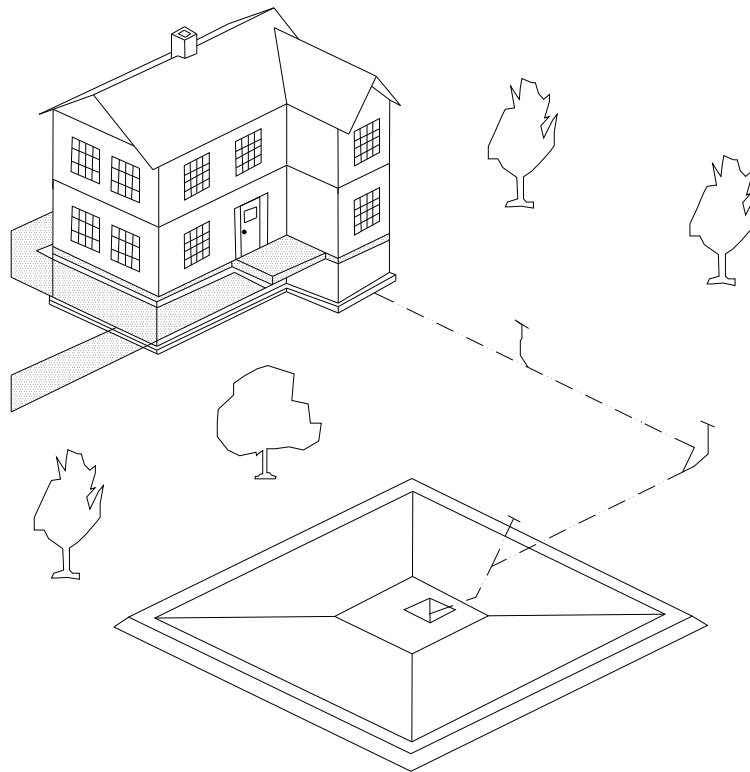

11.2 FUNCTION

The purpose of the lagoon cell is to provide the right environmental conditions for a combination of natural, physical, biological, and chemical processes to treat wastewater. It is among the simplest and least expensive sewage disposal systems that may utilize either raw sewage or septic tank effluent.

11.2.1 Anaerobic Lagoons

Anaerobic lagoons are most often used to treat animal wastes from dairies and pig farms, commercial or industrial wastes, or as the first treatment step in systems using two or more lagoons in a series. These lagoons are fairly deep 2.5 to 4.5 m (8 to 15 ft), have limited oxygen content, have a top layer consisting of grease and scum, and function similar to a septic tank. Odour is often a problem with these lagoons, requiring additional efforts to properly locate and maintain these lagoons.

11.2.2 Aerobic Lagoons

Aerobic lagoons are shallow lagoons that allow sunlight and oxygen from air and wind to completely penetrate the wastewater. The shallow depths of these lagoons make them better suited for warm, sunny climates, where freezing is less likely to occur.

11.2.3 Facultative Lagoons

Facultative lagoons combine the attributes of anaerobic and aerobic lagoons, forming three active layers. These lagoons are better suited for varied weather conditions and changes to incoming effluent volumes. Facultative lagoons are the type of lagoon best suited for the Saskatchewan and Canadian climate.

Facultative lagoons develop three layers or zones – each zone possessing different conditions under which different wastewater treatment occurs. Although each zone has processes specific to it, the processes are interdependent – each zone depends on the others for the processes within each zone to be successful.

The top layer, or aerobic zone, has the largest concentration of oxygen and the greatest sunlight exposure. The depth of this layer is dependent on the loading rate, climate, amount of sunlight and wind, and the amount of algae. This zone also provides an odour barrier for the gases produced in the lower layers.

The mid depth region of this lagoon is the zone where facultative bacteria live. They live and grow with or without dissolved oxygen.

The bottom layer, or anaerobic zone, has no oxygen present and contains the layer of sludge that forms as solids settle out of the wastewater. Anaerobic bacteria, microscopic organisms, and sludge worms, work together to treat the wastewater in this zone.

Several environmental processes are necessary for facultative lagoons to effectively treat the wastewater.

Wind contributes oxygen but it also affects the movement of the entire depth of wastewater in the lagoon – both are important for wastewater treatment. The lagoon must be placed so that it is able to make the best use of the wind in the area.

Time is necessary to allow for adequate settling and for the other environmental processes (biological, chemical, and physical) to reduce the overall organic load in the wastewater. As most facultative lagoons in Saskatchewan are similar to holding ponds, adequate time is also required for evaporation to maintain the working level of the lagoon.

Sunlight contributes to the growth of algae at the water surface which in turn contributes oxygen to the aerobic, top, zone. When designing a lagoon it is important to place it in an area where it will receive the greatest amount of sunlight. It is also important to ensure that trees are not allowed to grow around it and that water plants are not allowed to grow on the surface – both reduce the level of sunlight reaching the water.

Oxygen is necessary in the aerobic zone to ensure aerobic bacteria receive adequate oxygen levels.

Bacteria, both aerobic and anaerobic, are equally important in the treatment of wastewater – both converting wastewater into other substances. Anaerobic bacteria break down substances in wastewater to hydrogen sulfide, ammonia, and methane gases that are used by aerobic bacteria and algae. Aerobic bacteria break down wastes into carbon dioxide, ammonia, and phosphates that are used by algae as food.

11.2.4 Aerated Lagoons

Aerated lagoons utilize aeration systems to either add oxygen to the wastewater, or to mix the wastewater with air from the surface thus increasing the oxygen content in the wastewater. This type of lagoon requires less land area, but it is more energy and labour demanding.

11.2.5 Advantages

- ❑ Lagoon systems can be cost-effective to design and construct in areas where land is inexpensive.
- ❑ They use less energy than most wastewater treatment methods.
- ❑ They are simple to operate and maintain.
- ❑ They can handle intermittent use and shock loadings better than many systems, making them a good option for seasonal properties.
- ❑ They are very effective at removing disease-causing organisms (pathogens) from wastewater.
- ❑ The effluent from lagoon systems can be suitable for irrigation (where appropriate), because of its high-nutrient and low pathogen content.

11.2.6 Disadvantages

- ❑ Lagoon systems require more land than other treatment methods.
- ❑ They are less efficient in cold climates and may require additional land or longer detention times in these areas.
- ❑ Odour can become a nuisance during algae blooms, spring thaw in cold climates, or with anaerobic lagoons and lagoons that are inadequately maintained.
- ❑ Unless they are properly maintained, lagoons can provide a breeding area for mosquitoes and other insects.
- ❑ They are not very effective at removing heavy metals from wastewater.
- ❑ Effluent from some types of lagoons contains algae and often requires additional treatment or “polishing” to meet local discharge standards.

11.2.7 In Series Versus In Parallel Lagoon Systems

Multiple lagoons are more common in community or commercial settings than for individual households, where lagoons may be in series, in parallel, or a combination of the two. Two or more smaller lagoons generally provide better quality wastewater treatment than one large lagoon, making a multiple lagoon system effective in the treatment of more hazardous wastewater.

- ❑ **IN SERIES:**
Lagoons operating in series allow the movement of wastewater from one lagoon to the next. Each lagoon allows for more of the solid material in the wastewater to settle out.
- ❑ **IN PARALLEL:**
Lagoons operating in parallel are all receiving wastewater at the same stage of treatment. This type of system is useful in cold climates where wastewater treatment slows down in cold temperatures.

11.3 DESIGN

If properly designed, installed and maintained, a lagoon system can effectively treat household wastewater for many years. Lagoons are designed to handle all household wastes. Lagoon size is determined by the amount of sewage entering it. All piping used in or in conjunctions with a lagoon must be of a type that is acceptable to the local health region.

11.3.1 Capacity

Lagoons should have a minimum retention time of one year while maintaining a working (liquid) depth of not greater than 1.8 m (6 ft).

The dimensions of the lagoon are based on whether or not the lagoon will be discharged and the expected sewage flow. When considering the expected sewage flow, include a reasonable future growth that will occur within five years of the original completion of the project. This will allow for an adequately sized lagoon, but will not oversize the lagoon during its initial operation.

Evaporation is the main instrument for effluent management as evaporation rates exceed rainfall rates in most regions of Saskatchewan. However, in certain situations lagoons may be permitted to have controlled discharges.

11.3.2 Sizing For Lagoons That Are Intended To Be Discharged

These type of lagoons may, subject to the approval of the local health region, be discharged in controlled amounts, usually once per year. The discharge typically occurs after spring thaw and, if necessary, again in the fall after freeze up. Refer to Table 11.1 for the dimensions of a lagoon that discharges once per year .

Table 11.1
Examples For Lagoon Sizes

Approximate Sewage Flows		Size At Base/ "A" Length	Size at Liquid Depth/ "B" Length	Size at Centre Line of Berm/ "C" Length
m ³ /year	Litres/year (gals/year)	M (ft)	M (ft)	M (ft)
196	196,490 (43,810)	4.57 x 4.57 (15 x 15)	15.37 x 15.37 (50 x 50)	20.37 x 20.37 (67x 67)
255	255,380 (56,176)	6.10 x 6.10 (20 x 20)	16.90 x 16.90 (55 x 55)	21.9 x 21.9 (72 x 72)
323	322,630 (70,969)	7.62 x 7.62 (25 x 25)	18.42 x 18.42 (60 x 60)	23.42 x 23.42 (77 x 77)
398	398,250 (87,602)	9.14 x 9.14 (30 x 30)	19.94 x 19.94 (65 x 65)	24.94 x 24.94 (82 x 82)
482	482,220 (106,074)	10.67 x 10.67 (35 x 35)	21.47 x 21.47 (70 x 70)	26.47 x 26.47 (87 x 87)
575	574,560 (126,385)	12.19 x 12.19 (40 x 40)	22.99 x 22.99 (75 x 75)	27.99 x 27.99 (92 x 92)
784	784,310 (172,525)	15.24 x 15.24 (50 x 50)	26.04 x 26.04 (85 x 85)	31.04 x 31.04 (102 x 102)
1,028	1,027,510 (226,022)	18.29 x 18.29 (60 x 60)	29.09 x 29.09 (95 x 95)	34.09 x 34.09 (112 x112)
1,304	1,304,160 (286,875)	21.34 x 21.34 (70 x70)	32.14 x 32.14 (105 x 105)	37.14 x 37.14 (122 x 122)
2,335	2,334,770 (513,578)	30.48 x 30.48 (100 x 100)	41.28 x 41.28 (135 x 135)	46.28 x 46.28 (152 x 152)
3,189	3,189,070 (701,497)	36.58 x 36.58 (120 x 120)	47.38 x 47.38 (155 x 155)	52.38 x 52.38 (172 x 172)
4,721	4,721,350 (1,038,553)	45.72 x 45.72 (150 x 150)	56.52 x 56.52 (185 x 185)	61.52 x 61.52 (202 x 202)
6,228	6,228,190 (1,370,012)	53.34 x 53.34 (175 x 175)	64.14 x 64.14 (210 x 210)	69.14 x 69.14 (227 x 227)

11.3.3 Sizing For Lagoons That Are NOT Intended To Be Discharged

Sizing of this type of sewage lagoon must allow for evaporation of the sewage to remove the need to pump out the lagoon. For this reason, it is important to consider annual precipitation and evaporation rates in the overall design. See Appendix 18. A lagoon should be designed to provide sufficient surface area to evaporate 125% of the expected annual volume of sewage discharged into it. The design surface area should provide adequate storage to hold expected volumes of sewage during winter months or other periods of low net evaporation.

The following formulas are used to determine the required dimensions of a lagoon to accomplish the evaporation of 125% of the expected sewage per year based on average precipitation and evaporation rates.

Step 1 Rate of Evaporation (Revap)
per year = (mm of Evaporation per Year – mm of Precipitation per Year)

Step 2 Volume of Evaporation (Vevap)
From each m²/year
= $\frac{\text{Revap} \times 1,000,000 \text{ mm/m}^2}{1,000,000 \text{ cubic mm/L}}$
= _____ L/m²/yr

Step 3 The Area of Lagoon Required:
= $\frac{\text{Volume of Sewage Produced per year (m}^3) \times 1.25}{\text{Volume of Evaporation (L/m}^2\text{/yr)}}$

Step 4 Size at center line of berm "C" length.
= B + H:Vslope x Freeboard x 2 + 2 x ½ (berm width)

Step 5 Select an operating depth (eg. 1.2 m)

Step 6 Size at base "A" length
= B - H:Vslope x Depth x 2

See Appendix 19 for example.

11.3.4 Lagoon Construction

Lagoon specifications should also include the following:

- The submerged inlet should be placed not more than 450 mm (18 in) and not less than 300 mm (12 in) above the bottom of the lagoon. It is important to provide frost protection for the inlet pipe. This can be achieved by ensuring that there is always a minimum depth of 600 mm over the inlet pipe by using straw bales to create a small containment area or by ensuring that the lagoon is designed for a higher operating level.

- ❑ The berm should have a minimum slope of one vertical to three horizontal.
- ❑ The lagoon should have an interior surface layer of compacted clay of not less than 300 mm (12 in) thickness.
- ❑ The lagoon should have a berm with a top width of 2 m (6 ft).
- ❑ The lagoon should have a free board of 0.5 m (1.6 ft).
- ❑ The lagoon should have an emergency overflow pipe of 100 mm (4 in) diameter located at least 150 mm (6 in) above the full storage (working level) level of the wastewater.
- ❑ A workable landscape and maintenance schedule should be provided that will ensure the berm is adequately maintained.
- ❑ The lagoon should be located downwind from the premises it is serving.
- ❑ The site of the lagoon must be away from water supplies.
- ❑ The dykes on the lagoon should be sloped and grassed and the grass maintained.
- ❑ The lagoon must be adequately fenced in with a locking gate of a size that will allow a vehicle through it. It is also recommended that appropriate signage be placed at intervals along the fence perimeter.
- ❑ Sewage moved by gravity should be via a drainpipe that is laid at a minimum slope of one percent (1 m per 100 m). The pumping equipment to “lift” sewage from a septic tank to the lagoon needs to be properly sized with regard to pump head loss and must have an adequate number of accessible valves to permit servicing.
- ❑ The isolation distance between the base of the lagoon and the high water table must be 1.5 m (5 ft) where the soil is clay or similar material, or 7.6 m (25 ft) where the soil is sand or similar. The local health region may allow a lesser distance between the base of the lagoon and the water table if the lagoon is adequately lined with clay, plastic or other impermeable material.
- ❑ Where plastic is used as a liner, the bottom of the lagoon should be leveled and free of any roots or sharp stones; the walls should be smooth and packed. Black plastic, a minimum thickness of 6 mm, should be used as it does not deteriorate in the sunlight. Laying of the plastic should begin from the centre of the lagoon with all seams overlapped and sealed with waterproof plastic tape. Particular attention should be given to sealing any pipe entries. The ends of the liner material may be anchored in a trench in the top of the berms around the perimeter of the lagoon.

Figure 11.2 – Sewage Lagoon Sizing

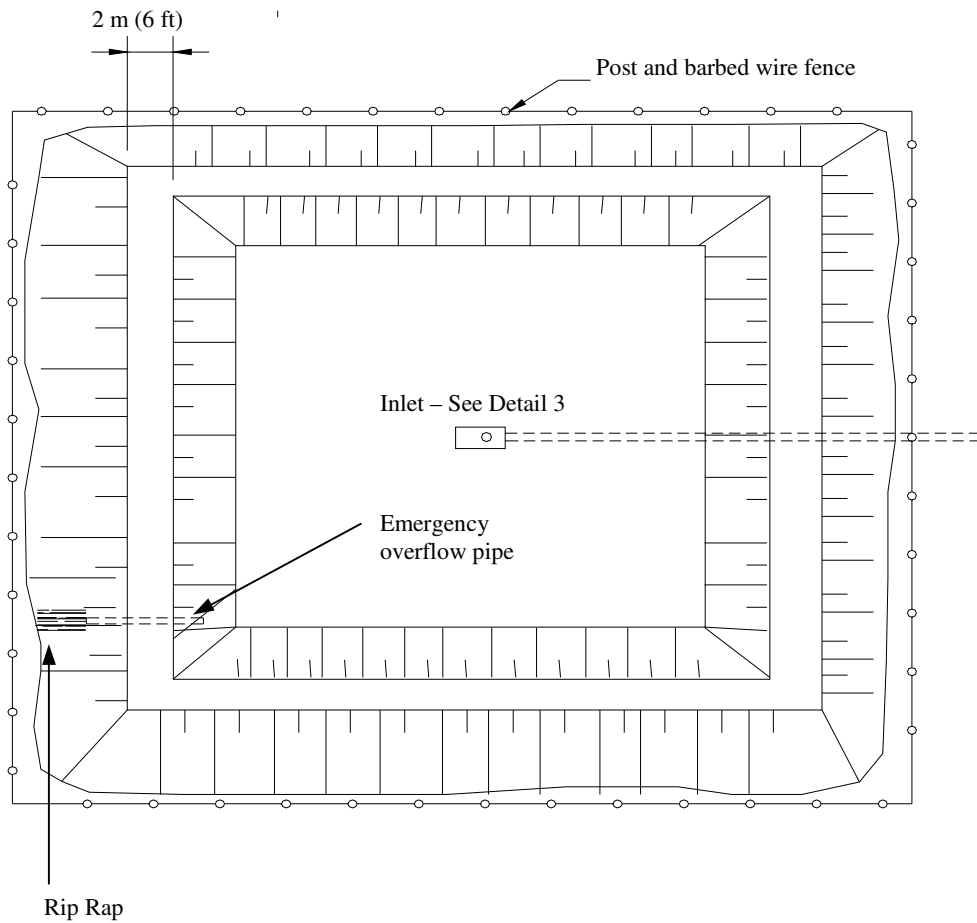
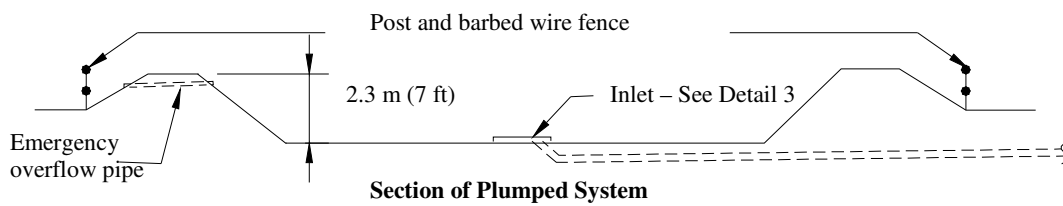
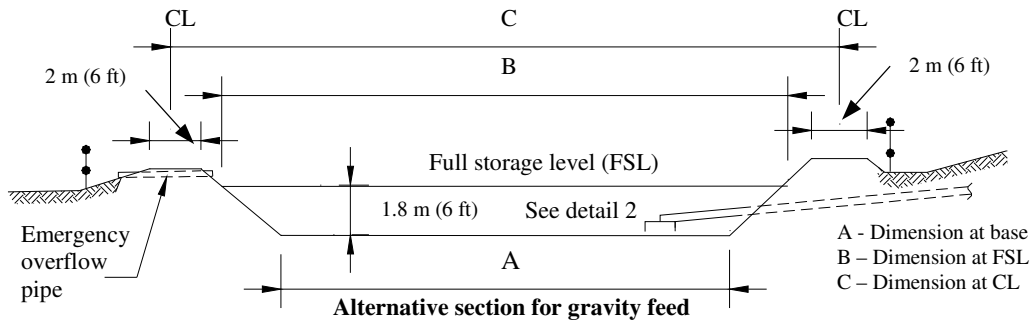
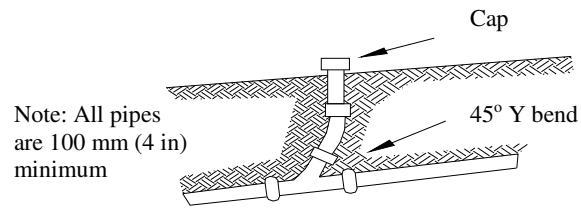
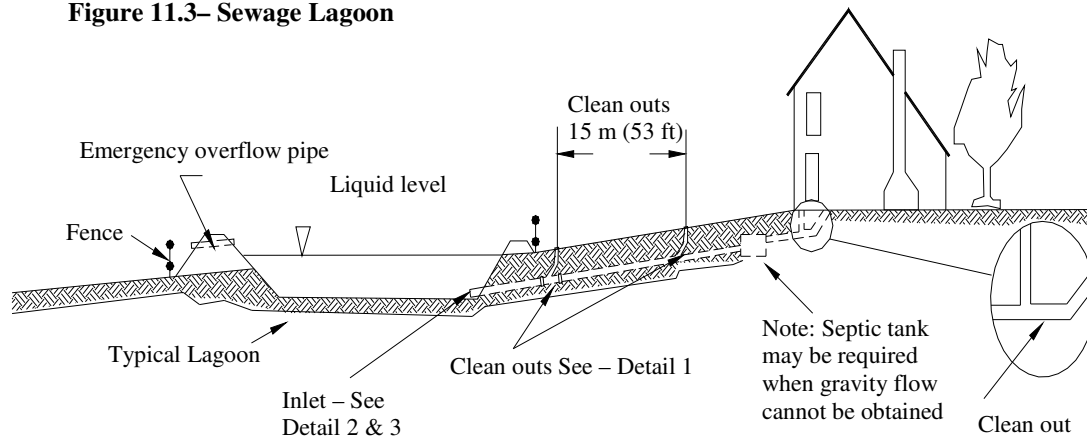
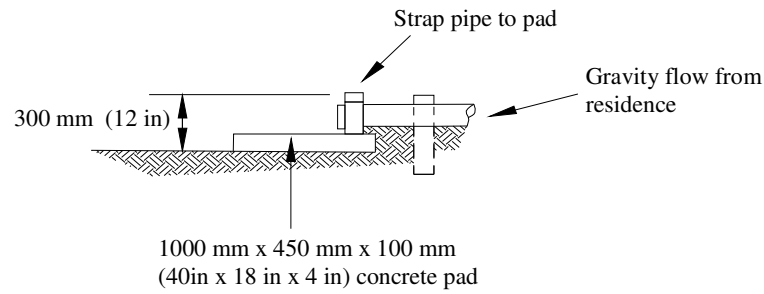

Figure 11.3– Sewage Lagoon



Detail 1



Detail 2

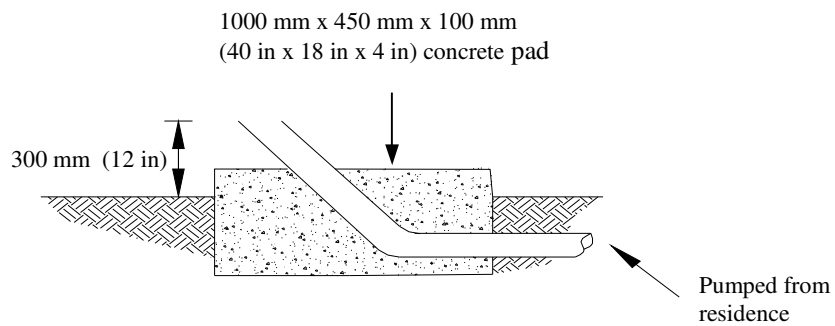

Detail 3

11.4 INSTALLATION

Lagoon installation is generally site and situation specific, but there are general construction practices that all lagoons should adhere to.

11.4.1 Site Selection

A lagoon may treat either raw sewage or septic tank effluent, via either gravity flow or with the assistance of a “lift”. If the slope of the land places the ground level of the lagoon 2.4 m lower than the premises it serves, gravity should effectively move the sewage into the lagoon.

Should the lagoon be at a higher elevation than the premises it serves, the sewage must be “lifted” to the lagoon.

11.4.2 Setback Requirements

The following setback distances must be met to ensure the lagoon does not interfere with persons, communities, or property:

<input type="checkbox"/> Building	60 m (200 ft)
<input type="checkbox"/> Recreation Areas	60 m (200 ft)
<input type="checkbox"/> Property Boundary	30 m (100 ft)
<input type="checkbox"/> Roadway	90 m (300 ft)
<input type="checkbox"/> Cut or embankment	30 m (100 ft)
<input type="checkbox"/> Ground water table	1.5 m (5 ft)
<input type="checkbox"/> Well*	90 m (300 ft)
<input type="checkbox"/> Water Course	90 m (300 ft)

* Unless otherwise approved by the local authority (through consultation with Saskatchewan Ministry of Environment officials), the setback distance from a well that is used as a water source for a municipal waterworks should be at least 75 m (250 ft) in the case of a small municipality (less than 1,000 population) and at least 225 m (750 ft) in the case of a large municipality (1,000 or more population).

A parcel/lot of land may not be less than 4 hectares (10 acres) in size for a lagoon to be placed on it, and any discharge from the lagoon must be contained on the property.

11.4.3 Inspection

Before the lagoon piping is covered the local health region shall be contacted to request an inspection. A Public Health Inspector with the local health region may inspect the installation or provide approval to proceed with covering.

11.5 CARE AND MAINTENANCE

Properly built lagoon systems experience few problems. It is normal for a properly sized lagoon to have a musky odour during warmer weather, after prolonged periods of cloudy weather, ice cover or temporary overloading.

Although lagoons generally require minimal maintenance, it is important that the lagoon is properly maintained to ensure efficient wastewater treatment. Routine inspections must be performed to assess the condition of the banks, dykes, grounds around the lagoon, inlet and outlet pipes, and the appearance, level, and odour (if any) of the water. Records should also be kept of each inspection that includes observations of influencing factors, such as the weather. A well operated and maintained lagoon will have stored wastewater that is green in colour with no unpleasant odour.

The following are routine maintenance practices to ensure trouble free operation:

- ❑ The reduction in sunlight availability to the water surface, and the associated reduction in oxygen production by algae, may be the result of plants with floating leaves and scum formation on the water surface. Floating debris may be removed from a boat with a rake or skimmer.
- ❑ Sludge accumulation around the inlet and in the bottom of the lagoon may result in objectionable odour or block the inlet pipe. It is recommended to measure the sludge depth at the bottom of the lagoon at least once per year and removing sludge as needed. A sludge mound may be dispersed by high pressure hosing, or by dragging a car bumper in a crisscross fashion, with a boat. It is important to flag the inlet pipe prior to any maintenance to ensure it is not damaged.
- ❑ Vegetation on the dyke must be controlled/maintained, as well as any vegetation growing along the water's edge. Vegetative growth should be regularly mowed and weeded, or burned. It is important that a sterilant is **not** used to control weeds in and around sewage lagoons.
- ❑ Algae blooms may result when algae multiply quickly and then die-off after periods of cloudy weather or abrupt temperature changes. These mats of algae may block sunlight and cause foul odours, and should be broken up and dispersed.

11.5.1 Common Problems

The following are problems that may occur in a lagoon and solutions to correct the problem:

- ❑ Lagoons may develop odours from algae blooms, anaerobic conditions, scum and turnover of the lagoon contents after thawing. The key to preventing odours from developing is proper operation and maintenance. Odour problems due to anaerobic conditions may be controlled by: aerating the cell with oxygen via a surface aerator or subsurface tubing; or adding sodium nitrate as an oxygen source. The treatment rate for sodium nitrate is 112 kg/ha (247 lbs/acre) of water surface area on the first day, and 56 kg/ha (123 lbs/acre) per day for each day thereafter that the odour persists. Sodium nitrate may be applied at a lift station, at a service hole prior to the lagoon, or broadcast from a boat.
- ❑ Should a lagoon begin to leak, bentonite may be used to temporarily seal (this treatment will only seal for a maximum of three years) the lagoon. A rate of 45 kg (100 lbs) of bentonite (available from well drilling supply companies) is required for every 93 m² (1,000 ft²) of surface to be sealed. The bentonite requires thorough mixing with the lagoon liquid and should be agitated to keep it in suspension for several hours before it is allowed to settle and form a seal.
- ❑ Burrowing animals, such as muskrats, may damage and weaken the dyke. Burrowing animals may be discouraged by weeding and mowing lagoon banks, as well as raising and lowering water levels which will interfere with water levels at the tunnel openings. If the rodents do become a problem, they should be eliminated and the damage to the dyke repaired.
- ❑ Seepage around the toe of the dyke should be frequently assessed as seepage may weaken the dyke and lead to structural damage. Damage of this type requires structural repair – consult the local health region.
- ❑ Erosion of the inner slope of the lagoon may be caused by wave action, surface run-off, improper grading, and burrowing animals. Installation of rip-rap, a stone or rock surface, both above and below the water surface may help to reduce erosion. Properly grading the dyke will prevent surface run-off around the perimeter of the dyke.

11.5.2 Safety

The design of a lagoon must include adequate fencing provisions. The fence should be designed to preclude the entrance of children and to discourage trespassing. Livestock should also be prevented from entering. Fences should be located away from the outside toe of the berm to facilitate mowing and maintenance operations.

Where a lagoon is located near developed areas a chain link fence may be required to prevent children from gaining entrance. In addition, an access gate should be provided to allow entry of maintenance equipment. The gate should be equipped with a lock to prevent unauthorized entry. Signs should also be posted to identify the lagoon and advise against trespassing.

12.1 DEFINITION

A package sewage treatment plant is a unit which complies with the National Sanitation Foundation International Standard for Wastewater Technology, NSF-40 Standard, Residential Wastewater Treatment Systems, Class 1 or other Standard(s) recognized by the local health region.

12.2 FUNCTION

Package sewage treatment plants are often aerobic treatment plants that use various methods, depending on their design, to expose sewage to oxygen. Increased levels of oxygen in the sewage provides for the establishment of large aerobic bacteria populations. These aerobic bacteria populations accelerate the decomposition of the suspended solids in sewage. Resulting effluent can then be pumped or drained into a system that is approved by the local health region.

12.3 DESIGN

Package sewage treatment plants perform best when they are subjected to a constant and consistent volume and quality of sewage. It takes some time to initially establish a bacteria population as there is a balance between the size of bacteria population, the amount of solids discharged to the package sewage treatment plant that the bacteria can use as food, and the amount of oxygen available to the bacteria. If there is a sudden increase in the amount of solids, there may be a decrease in the quality of effluent discharged from the package treatment plant until the bacteria population increases in size to accommodate the new volume of solids.

Sewage that exceeds the maximum limits for residential strength sewage should not be discharged to a package sewage treatment plant. If the sewage discharged from the facility served is in excess of residential strength sewage, the sewage must be pre-treated. Residential Strength Sewage means sewage which has a Biological Oxygen Demand (BOD₅) of less than 300 mg/L, Total Suspended Solids (TSS) of less than 350 mg/L, and an oil and grease content of less than 25 mg/L.

The minimum treatment capacity of a package sewage treatment plant should be not less than 1800 L (400 gals) per day, and not less than the expected volume of sewage per day.

Output effluent from a package sewage treatment plant must be treated in an approved private sewage works.

An subsurface wastewater infiltration system supplied with effluent from a package sewage treatment plant may, when approved by the Public Health Inspector, have a 30% reduction in the area of lateral trench bottom as mentioned in Sections 7 and 8.

Access openings and manhole extensions should prevent water from entering the package sewage treatment plant.

12.4 INSTALLATION

12.4.1 Setback Requirements

When installing a package sewage treatment plant, it shall have a minimum setback distance as follows:

<input type="checkbox"/> Building	1 m (3 ft)
<input type="checkbox"/> Property Boundary	3 m (10 ft)
<input type="checkbox"/> Walk/Driveway	1.5 m (5 ft)
<input type="checkbox"/> Cut or embankment	3 m (10 ft)
<input type="checkbox"/> Ground water table	1.5 m (5 ft)
<input type="checkbox"/> Well	9 m (30 ft)
<input type="checkbox"/> Water Course	9 m (30 ft)

A package treatment plant that includes a disposal component must meet appropriate set-back distances for that disposal option.

The package sewage treatment plant should be located so as not to impact on the water table. If a contractor is in doubt as to what would be considered an appropriate separation, they should contact their local health region before installation.

A package sewage treatment plant should be provided with an access opening at or above the ground surface to permit entry for routine maintenance. Access openings that are not protected by their location must be equipped with a secure lid or cover to prevent unauthorized or accidental entry into the tank. An access opening extension shall be water tight at the connection to the packaged sewage treatment plant and at the joints between all sections.

The bottom of an excavation for a package sewage treatment plant should provide a uniform base to support the tank in a level position. The tank must have a stable base to prevent damage due to settling, shifting or cracking after installation.

Piping connected to the packaged sewage treatment plant should be supported to within 300 mm (1 ft) from the tank on a solid base, or equivalent.

12.4.2 Inspection

Before the system is covered the local health region shall be contacted to request an inspection. A Public Health Inspector with the local health region may inspect the installation or provide approval to proceed with the covering of the system.

12.5 CARE & MAINTENANCE

Routine maintenance of a package treatment plant is required to ensure quality of effluent. Refer to the manufacturer's recommendations for specific maintenance protocol. The quality of the effluent should meet the objectives specified by the standard to which the package treatment plant is certified.

APPENDIX 1 – DISPOSAL FIELD DESIGN DATA

				2 Bedrooms		3 Bedrooms		4 Bedrooms		5 Bedrooms		6 Bedrooms	
Perc Rate	SQRT of Perc Rate	Loading rate L/sq m	Loading rate Gal/sq ft	Square Metres 2 BR = 340x2x2 1360 L	Sq ft Reqd 2 BR= 75x2x2 300 gal	Sq Metre 3 BR = 340 x1.5x3 1530 L	Sq ft Reqd 3 BR = 75x1.5x3 337.5 gal	Sq Metre 4 BR = 340 x1.5x4 2040 L	Sq ft Reqd 4 BR = 75x1.5x4 450 gal	Sq Metre 5 BR = 340 x1.5x5 2550 L	Sq ft Reqd 5 BR = 75x1.5x5 562.5 gal	Sq Metre 6 BR = 340 x1.5x6 3060 L	Sq ft Reqd 6 BR = 75x1.5x6 675 gal
PER DAY													
5	2.236	36.46	0.75	37.05	399.3	41.68	449.21	55.57	598.95	69.47	748.68	83.36	898.42
6	2.449	33.28	0.69	40.59	437.41	45.66	492.09	60.88	656.11	76.1	820.14	91.32	984.17
7	2.646	30.82	0.64	43.84	472.46	49.32	531.51	65.76	708.68	82.2	885.85	98.64	1063.03
8	2.828	28.83	0.59	46.86	505.08	52.72	568.21	70.3	757.61	87.87	947.02	105.45	1136.42
9	3	27.18	0.56	49.71	535.71	55.92	602.68	74.56	803.57	93.2	1004.46	111.84	1205.36
10	3.162	25.78	0.53	52.4	564.69	58.95	635.28	78.59	847.04	98.24	1058.8	117.89	1270.56
11	3.317	24.58	0.51	54.95	592.25	61.82	666.29	82.43	888.38	103.04	1110.48	123.65	1332.57
12	3.464	23.54	0.49	57.4	618.59	64.57	695.91	86.1	927.88	107.62	1159.86	129.14	1391.83
13	3.606	22.61	0.47	59.74	643.85	67.21	724.33	89.61	965.77	112.01	1207.22	134.42	1448.66
14	3.742	21.79	0.45	62	668.15	69.75	751.67	92.99	1002.23	116.24	1252.79	139.49	1503.34
15	3.873	21.05	0.43	64.17	691.6	72.19	778.05	96.26	1037.41	120.32	1296.76	144.39	1556.11
16	4	20.38	0.42	66.28	714.29	74.56	803.57	99.42	1071.43	124.27	1339.29	149.12	1607.14
17	4.123	19.77	0.41	68.32	736.27	76.86	828.3	102.47	1104.4	128.09	1380.5	153.71	1656.6
18	4.243	19.22	0.4	70.3	757.61	79.08	852.32	105.45	1136.42	131.81	1420.53	158.17	1704.63
19	4.359	18.7	0.39	72.22	778.37	81.25	875.67	108.34	1167.56	135.42	1459.45	162.5	1751.34
20	4.472	18.23	0.38	74.1	798.6	83.36	898.42	111.15	1197.89	138.94	1497.37	166.72	1796.84
21	4.583	17.79	0.37	75.93	818.32	85.42	920.61	113.89	1227.48	142.37	1534.34	170.84	1841.21
22	4.69	17.38	0.36	77.72	837.57	87.43	942.27	116.57	1256.36	145.72	1570.45	174.86	1884.54
23	4.796	17	0.35	79.46	856.4	89.4	963.45	119.19	1284.6	148.99	1605.75	178.79	1926.9
24	4.899	16.64	0.34	81.17	874.82	91.32	984.17	121.76	1312.23	152.2	1640.28	182.64	1968.34
25	5	16.31	0.34	82.85	892.86	93.2	1004.46	124.27	1339.29	155.34	1674.11	186.4	2008.93
26	5.099	15.99	0.33	84.49	910.54	95.05	1024.36	126.73	1365.81	158.41	1707.26	190.1	2048.71
27	5.196	15.69	0.32	86.1	927.88	96.86	1043.87	129.14	1391.83	161.43	1739.78	193.72	2087.74
28	5.292	15.41	0.32	87.68	944.91	98.64	1063.03	131.51	1417.37	164.39	1771.71	197.27	2126.05
29	5.385	15.14	0.31	89.23	961.64	100.38	1081.84	133.84	1442.45	167.3	1803.07	200.76	2163.68
30	5.477	14.89	0.31	90.75	978.08	102.1	1100.34	136.13	1467.11	170.16	1833.89	204.19	2200.67
31	5.568	14.64	0.3	92.25	994.24	103.79	1118.52	138.38	1491.37	172.98	1864.21	207.57	2237.05
32	5.657	14.41	0.3	93.73	1010.4	105.45	1136.42	140.59	1515.23	175.74	1894.04	210.89	2272.84
33	5.745	14.19	0.29	95.18	1025.81	107.08	1154.04	142.77	1538.72	178.47	1923.4	214.16	2308.08
34	5.831	13.98	0.29	96.61	1041.24	108.69	1171.4	144.92	1561.86	181.15	1952.33	217.38	2342.79
35	5.916	13.78	0.28	98.02	1056.44	110.28	1188.5	147.04	1584.66	183.8	1980.83	220.56	2377
36	6	13.59	0.28	99.42	1071.43	111.84	1205.36	149.12	1607.14	186.4	2008.93	223.68	2410.71
37	6.083	13.4	0.28	100.79	1086.21	113.38	1221.98	151.18	1629.31	188.97	2036.64	226.77	2443.97
38	6.164	13.23	0.27	102.14	1100.79	114.91	1238.39	153.21	1651.18	191.51	2063.98	229.81	2476.77
39	6.245	13.06	0.27	103.47	1115.18	116.41	1254.58	155.21	1672.77	194.01	2090.96	232.82	2509.15
40	6.325	12.89	0.27	104.79	1129.38	117.89	1270.56	157.19	1694.08	196.49	2117.6	235.78	2541.12
41	6.403	12.73	0.26	106.09	1143.42	119.36	1286.34	159.14	1715.12	198.93	2143.9	238.71	2572.68
42	6.481	12.58	0.26	107.38	1157.28	120.8	1301.93	161.07	1735.91	201.34	2169.89	241.61	2603.87
43	6.557	12.43	0.26	108.65	1170.97	122.23	1317.34	162.98	1756.46	203.72	2195.57	244.47	2634.69
44	6.633	12.29	0.25	109.91	1184.51	123.65	1332.57	164.86	1776.76	206.08	2220.95	247.29	2665.14
45	6.708	12.15	0.25	111.15	1197.89	125.04	1347.63	166.72	1796.84	208.41	2246.05	250.09	2695.26
46	6.782	12.02	0.25	112.38	1211.13	126.43	1362.52	168.57	1816.7	210.71	2270.87	252.85	2725.04
47	6.856	11.89	0.25	113.59	1224.22	127.79	1377.25	170.39	1836.34	212.99	2295.42	255.58	2754.5
48	6.928	11.77	0.24	114.79	1237.18	129.14	1391.83	172.19	1855.77	215.24	2319.71	258.29	2783.65
49	7	11.65	0.24	115.98	1250	130.48	1406.25	173.98	1875	217.47	2343.75	260.96	2812.5
50	7.071	11.53	0.24	117.16	1262.69	131.81	1420.53	175.74	1894.04	219.68	2367.55	263.61	2841.05
51	7.141	11.42	0.24	118.33	1275.26	133.12	1434.66	177.49	1912.88	221.86	2391.1	266.24	2869.32
52	7.211	11.31	0.23	119.48	1287.7	134.42	1448.66	179.22	1931.55	224.03	2414.43	268.84	2897.32
53	7.28	11.2	0.23	120.63	1300.02	135.7	1462.52	180.94	1950.03	226.17	2437.54	271.41	2925.04
54	7.348	11.09	0.23	121.76	1312.23	136.98	1476.26	182.64	1968.34	228.3	2460.43	273.96	2952.51
55	7.416	10.99	0.23	122.88	1324.32	138.24	1489.86	184.32	1986.48	230.4	2483.1	276.48	2979.72
56	7.483	10.9	0.22	123.99	1336.31	139.49	1503.34	185.99	2004.46	232.49	2505.57	278.98	3006.69
57	7.55	10.8	0.22	125.09	1348.18	140.73	1516.71	187.64	2022.28	234.55	2527.85	281.46	3033.42
58	7.616	10.71	0.22	126.19	1359.96	141.96	1529.95	189.28	2039.94	236.6	2549.92	283.92	3059.91
59	7.681	10.61	0.22	127.27	1371.63	143.18	1543.09	190.91	2057.45	238.63	2571.81	286.36	3086.17
60	7.746	10.53	0.22	128.34	1383.21	144.39	1556.11	192.52	2074.81	240.65	2593.52	288.78	3112.22

APPENDIX 1 – DISPOSAL FIELD DESIGN DATA

Perc Rate	SQRT of Perc Rate	Loading rate L/sq m	Loading rate Gal/sq ft	2 Bedrooms		3 Bedrooms		4 Bedrooms		5 Bedrooms		6 Bedrooms	
				Square Metres 2 BR = 340x2x2 1360 L	Sq ft Reqd 2 BR= 75x2x2 300 gal	Sq Metre 3 BR = 340 x1.5x3 1530 L	Sq ft Reqd 3 BR = 75x1.5x3 337.5 gal	Sq Metre 4 BR = 340 x1.5x4 2040 L	Sq ft Reqd 4 BR = 75x1.5x4 450 gal	Sq Metre 5 BR = 340 x1.5x5 2550 L	Sq ft Reqd 5 BR = 75x1.5x5 562.5 gal	Sq Metre 6 BR = 340 x1.5x6 3060 L	Sq ft Reqd 6 BR = 75x1.5x6 675 gal
PER DAY													
61	7.81	10.44	0.22	129.41	1394.69	145.59	1569.02	194.11	2092.03	242.64	2615.04	291.17	3138.05
62	7.874	10.35	0.21	130.47	1406.07	146.77	1581.83	195.7	2109.11	244.62	2636.39	293.55	3163.66
63	7.937	10.27	0.21	131.51	1417.37	147.95	1594.54	197.27	2126.05	246.59	2657.56	295.91	3189.08
64	8	10.19	0.21	132.55	1428.57	149.12	1607.14	198.83	2142.86	248.54	2678.57	298.25	3214.29
65	8.062	10.11	0.21	133.59	1439.69	150.28	1619.65	200.38	2159.53	250.47	2699.42	300.57	3239.3
66	8.124	10.04	0.21	134.61	1450.72	151.43	1632.06	201.91	2176.08	252.39	2720.1	302.87	3264.12
67	8.185	9.96	0.21	135.62	1461.67	152.58	1644.38	203.44	2192.51	254.3	2740.63	305.16	3288.76
68	8.246	9.89	0.2	136.63	1472.54	153.71	1656.6	204.95	2208.81	256.19	2761.01	307.42	3313.21
69	8.307	9.82	0.2	137.63	1483.33	154.84	1668.74	206.45	2224.99	258.06	2781.24	309.68	3337.48
70	8.367	9.74	0.2	138.63	1494.04	155.96	1680.79	207.94	2241.05	259.93	2801.32	311.91	3361.58
71	8.426	9.68	0.2	139.61	1504.67	157.07	1692.75	209.42	2257	261.78	2821.26	314.13	3385.51
72	8.485	9.61	0.2	140.59	1515.23	158.17	1704.63	210.89	2272.84	263.61	2841.05	316.34	3409.26
73	8.544	9.54	0.2	141.57	1525.72	159.26	1716.43	212.35	2288.57	265.44	2860.72	318.53	3432.86
74	8.602	9.48	0.2	142.53	1536.13	160.35	1728.15	213.8	2304.19	267.25	2880.24	320.7	3456.29
75	8.66	9.41	0.19	143.49	1546.47	161.43	1739.78	215.24	2319.71	269.05	2899.64	322.86	3479.57
76	8.718	9.35	0.19	144.45	1556.75	162.5	1751.34	216.67	2335.12	270.84	2918.91	325.01	3502.69
77	8.775	9.29	0.19	145.39	1566.96	163.57	1762.83	218.09	2350.44	272.61	2938.05	327.14	3525.66
78	8.832	9.23	0.19	146.34	1577.1	164.63	1774.24	219.5	2365.65	274.38	2957.06	329.25	3548.48
79	8.888	9.17	0.19	147.27	1587.18	165.68	1785.57	220.91	2380.77	276.13	2975.96	331.36	3571.15
80	8.944	9.12	0.19	148.2	1597.19	166.72	1796.84	222.3	2395.79	277.87	2994.73	333.45	3593.68
81	9	9.06	0.19	149.12	1607.14	167.76	1808.04	223.68	2410.71	279.61	3013.39	335.53	3616.07
82	9.055	9	0.19	150.04	1617.03	168.8	1819.16	225.06	2425.55	281.33	3031.94	337.59	3638.32
83	9.11	8.95	0.18	150.95	1626.86	169.82	1830.22	226.43	2440.29	283.04	3050.37	339.64	3660.44
84	9.165	8.89	0.18	151.85	1636.6	170.84	1841.18	227.78	2454.9	284.73	3068.63	341.67	3682.36
85	9.22	8.84	0.18	152.76	1646.35	171.86	1852.14	229.14	2469.52	286.43	3086.9	343.71	3704.28
86	9.274	8.79	0.18	153.66	1656	172.86	1863	230.48	2484.01	288.11	3105.01	345.73	3726.01
87	9.327	8.74	0.18	154.55	1665.6	173.87	1873.8	231.82	2498.41	289.78	3123.01	347.73	3747.61
88	9.381	8.69	0.18	155.43	1675.15	174.86	1884.54	233.15	2512.72	291.44	3140.9	349.72	3769.08
89	9.434	8.64	0.18	156.31	1684.64	175.85	1895.22	234.47	2526.96	293.09	3158.7	351.71	3790.44
90	9.487	8.59	0.18	157.19	1694.08	176.84	1905.84	235.78	2541.12	294.73	3176.4	353.68	3811.67
91	9.539	8.55	0.18	158.06	1703.46	177.82	1916.4	237.09	2555.19	296.36	3193.99	355.64	3832.79
92	9.592	8.5	0.18	158.93	1712.8	178.79	1926.9	238.39	2569.2	297.99	3211.49	357.58	3853.79
93	9.644	8.45	0.17	159.79	1722.08	179.76	1937.34	239.68	2583.12	299.6	3228.9	359.52	3874.68
94	9.695	8.41	0.17	160.64	1731.31	180.72	1947.73	240.97	2596.97	301.21	3246.21	361.45	3895.46
95	9.747	8.36	0.17	161.5	1740.5	181.68	1958.06	242.24	2610.75	302.81	3263.44	363.37	3916.12
96	9.798	8.32	0.17	162.34	1749.64	182.64	1968.34	243.52	2624.45	304.4	3280.57	365.27	3936.68
97	9.849	8.28	0.17	163.19	1758.72	183.59	1978.57	244.78	2638.09	305.98	3297.61	367.17	3957.13
98	9.899	8.24	0.17	164.03	1767.77	184.53	1988.74	246.04	2651.65	307.55	3314.56	369.06	3977.48
99	9.95	8.19	0.17	164.86	1776.76	185.47	1998.86	247.29	2665.14	309.12	3331.43	370.94	3997.72
100	10	8.15	0.17	165.69	1785.71	186.4	2008.93	248.54	2678.57	310.67	3348.21	372.81	4017.86
101	10.05	8.11	0.17	166.52	1794.62	187.33	2018.95	249.78	2691.93	312.22	3364.91	374.67	4037.9
102	10.1	8.07	0.17	167.34	1803.48	188.26	2028.92	251.01	2705.22	313.76	3381.53	376.52	4057.84
103	10.149	8.03	0.17	168.16	1812.3	189.18	2038.84	252.24	2718.45	315.3	3398.07	378.36	4077.68
104	10.198	7.99	0.16	168.97	1821.08	190.1	2048.71	253.46	2731.62	316.83	3414.52	380.19	4097.43
105	10.247	7.96	0.16	169.78	1829.81	191.01	2058.54	254.68	2744.72	318.34	3430.9	382.01	4117.08
106	10.296	7.92	0.16	170.59	1838.51	191.91	2068.32	255.89	2757.76	319.86	3447.2	383.83	4136.64
107	10.344	7.88	0.16	171.39	1847.16	192.82	2078.05	257.09	2770.74	321.36	3463.42	385.63	4156.1
108	10.392	7.85	0.16	172.19	1855.77	193.72	2087.74	258.29	2783.65	322.86	3479.57	387.43	4175.48
109	10.44	7.81	0.16	172.99	1864.34	194.61	2097.38	259.48	2796.51	324.35	3495.64	389.22	4194.77
110	10.488	7.77	0.16	173.78	1872.87	195.5	2106.98	260.67	2809.31	325.84	3511.64	391	4213.96
111	10.536	7.74	0.16	174.57	1881.37	196.39	2116.54	261.85	2822.05	327.31	3527.56	392.78	4233.08
112	10.583	7.7	0.16	175.35	1889.82	197.27	2126.05	263.03	2834.73	328.78	3543.42	394.54	4252.1
113	10.63	7.67	0.16	176.13	1898.24	198.15	2135.52	264.2	2847.36	330.25	3559.2	396.3	4271.04
114	10.677	7.64	0.16	176.91	1906.62	199.02	2144.95	265.37	2859.93	331.71	3574.91	398.05	4289.9
115	10.724	7.6	0.16	177.68	1914.97	199.9	2154.34	266.53	2872.45	333.16	3590.56	399.79	4308.67
116	10.77	7.57	0.16	178.46	1923.27	200.76	2163.68	267.68	2884.91	334.6	3606.14	401.53	4327.36

APPENDIX 1 – DISPOSAL FIELD DESIGN DATA

				2 Bedrooms		3 Bedrooms		4 Bedrooms		5 Bedrooms		6 Bedrooms	
Perc Rate	SQRT of Perc Rate	Loading rate L/sq m	Loading rate Gal/sq ft	Square Metres 2 BR = 340x2x2 1360 L	Sq ft Reqd 2 BR= 75x2x2 300 gal	Sq Metre 3 BR = 340 x1.5x3 1530 L	Sq ft Reqd 3 BR = 75x1.5x3 337.5 gal	Sq Metre 4 BR = 340 x1.5x4 2040 L	Sq ft Reqd 4 BR = 75x1.5x4 450 gal	Sq Metre 5 BR = 340 x1.5x5 2550 L	Sq ft Reqd 5 BR = 75x1.5x5 562.5 gal	Sq Metre 6 BR = 340 x1.5x6 3060 L	Sq ft Reqd 6 BR = 75x1.5x6 675 gal
PER DAY													
117	10.817	7.54	0.16	179.22	1931.55	201.63	2172.99	268.84	2897.32	336.04	3621.65	403.25	4345.98
118	10.863	7.51	0.15	179.99	1939.78	202.49	2182.26	269.98	2909.67	337.48	3637.09	404.97	4364.51
119	10.909	7.47	0.15	180.75	1947.98	203.34	2191.48	271.12	2921.98	338.9	3652.47	406.68	4382.96
120	10.954	7.44	0.15	181.51	1956.15	204.19	2200.67	272.26	2934.23	340.32	3667.79	408.39	4401.34

Caution: Disposal fields may only be installed on soils with a percolation rate faster than 60 min/inch. Loading rates & required areas from 61 to 120 minutes per inch is provided for the design of treatment mounds only.

APPENDIX 2 – EXPECTED VOLUME OF SEWAGE PER DAY

Facility	Expected sewage volume in litres (gallons) per day
Airport	10 (2.2) per passenger
Apartment	190 (42) per person
Assembly Hall/Town Hall/Churches	10 (2.2) per seat
Automotive Service Station/Garage/Gas Station	45 (10) per vehicle served 50 (11) per employee 550 (121) per double pump unit
Bar/Tavern/Cocktail Lounge	Customer 75 (16.5) Employee 50 (11)
Bowling Alley	400 (88) per lane
Cabin, Resort	150 (33) per person
Cafeteria (workplace – no food service)	10 (2.2) per customer 40 (9) per employee
Camps: Campgrounds with flush toilets, showers Day camps (No Meals Served) Also see Picnic Parks, Youth Camp	130 (28.6) per person 50 (11) per person
Construction Camp (semi-permanent)	190 (42) per person
Cottages and Small Dwellings with Seasonal Occup.	150 (33) per person
Country Club	400 (88) member present 50 (11) per employee
Dance Halls	45 (10) per person
Dining Hall	30 (6.6) per meal served
Dormitory, Bunkhouse	150 (33) per person
<i>Dwelling</i> single family and duplex	340 (75) per person at 2 persons per bedroom 2 bedrooms and less, or at 1.5 persons per bedroom 3 bedrooms and more
<i>Dwelling</i> (includes Mobile Home Trailers) - other than single family or duplex	675 (150) per bedroom
Golf Club	45 (10) per member
Hospital	630 (139) per bed
Hotel/Motel – Resort	200 (44) per person 40 (9) per employee
Industrial and Commercial <i>Building</i> (does not include process water, showers or a cafeteria)	50 (11) per employee
Industrial and Commercial <i>Building</i> (with showers)	90 (18) per employee
Laundry, Self Service	2100 (462) per machine
Mobile Home/Trailer Park	675 (150) per bedroom
Motel/Hotel	200 (44) per single bed
Nursing and Rest Homes	350 (77) per person
Office <i>Building</i>	50 (11) per employee
Picnic Parks:	toilets only bathhouses, showers, flush toilets
	20 (4.5) per picnicker 40 (9) per picnicker

APPENDIX 2 – EXPECTED VOLUME OF SEWAGE PER DAY

Facility		Expected sewage volume in litres (gallons) per day
Prison		450 (99) per inmate 40 (9) per employee
Restaurant	(including coffee shops) Licensed	40 (9) per customer 50 (11) per customer
Rooming House		150 (33) per seat
School, Day:	Cafeteria, gym, showers	80 (17.5) per student
	Cafeteria only	60 (13.2) per student
School, Boarding:	No cafeteria, gym, showers	40 (9) per student
		280 (62) per student
Shopping Center		5 (1) parking space 40 (9) per employee
Store, Department		2000 (440) per toilet room 40 (9) per employee
Swimming Pool (public)		40 (9) per person/employee
Theatres	Movie	10 (2) auditorium seat
	Drive-In	20 (4.5) car space
Visitor Centre		20 (4.5) per visitor
Youth Camp		190 (42) per person

Note:

- ❑ Volume in Brackets () is based on approximate conversion of volume from litres to gallons. Always use volume in litres per day/unit numbers to calculate the typical sewage volume.
- ❑ Should garburators be installed, the daily sewage flow calculation is to be increased by a factor of 25%.
- ❑ The provided volumes are provided only for the purpose of designing onsite sewage treatment systems.

Figures for the above table have been taken from:

Alberta Private Sewage Systems Standard of Practice 1999 – Handbook. Safety Codes Council .
Edmonton, Alberta.

The American Society of Plumbing Engineers: Data Book, 1981-82, Volume II- Special Plumbing
Systems Design.

The United States Environmental Protection Agency: Design Manual - Onsite Wastewater
Treatment and Disposal Systems. 1980.

The United States Environmental Protection Agency: Design Manual - Onsite Wastewater
Treatment Systems Manual. 2002.

APPENDIX 3 – TRENCH BOTTOM SYSTEM SIZING WORKSHEET

Step 1) You need to know:

- The daily sewage volume (size of dwelling served).
- The absorptive capacity of the soil where the system will be located.

Expected Volume of Sewage per Day

L/day (gals/day)

M1

Step 2) Determine the total soil treatment area required.

The soil loading rate can be determined from the soil texture classification (Appendix 15) or from percolation test results. If using the percolation test, Appendix 1, which provides the effluent loading rates for soils between 5 and 120 minutes per inch, shows the perc. rate in the left column with the appropriate dwelling size in the top row. Ex. Perc. rate 7 (loamy sand) matched with a 3 bedroom house indicates a soil treatment area of 49.32 m² or 531.51 ft² is required.

Expected Volume of Sewage per Day

L/day (gals/day)

From M1 this worksheet.

÷

Soil Loading Rate

From calculation, Appendix 15 or Appendix 1.

=

Total Soil Treatment Area Required

m² (ft²)

M2

Step 3) Calculate the minimum required “trench bottom area”:

Total Soil Treatment Area Required

m² (ft²)

From M2 above

X

Pretreatment or Pressure Distribution Reduction Factor

(1-_____)

=

Required Trench Bottom Area

m² (ft²)

M3

*A reduction of 30% can be applied where pretreatment is used (insert 0.30 in the blank space); or
 A reduction of 20% can be applied where non-chamber pressure distribution is used (insert 0.20 in the blank space).
 Where no reduction is available, insert 0.
 The above reductions cannot be added together. Select the maximum applicable.
The local authority must approve all field size reductions.*

APPENDIX 3 – TRENCH BOTTOM SYSTEM SIZING WORKSHEET

Step 4) Calculate the minimum allowable infiltration area

<p>Minimum Trench Bottom Size Allowed</p> <div style="border: 1px solid black; padding: 5px; width: fit-content; margin: 0 auto;">37 m² (400 ft²)</div> <p><i>37 m² (400 ft²) is the smallest trench bottom area allowable</i></p>	OR	<p>Required Trench Bottom Area</p> <div style="border: 1px solid black; padding: 5px; width: fit-content; margin: 0 auto;">m² (ft²)</div> <p><i>From M3 above</i></p>	<p>Trench Bottom Area</p> <div style="border: 1px solid black; padding: 5px; width: fit-content; margin: 0 auto;">m² (ft²)</div> <p><i>Maximum of the two previous boxes</i></p>	M4
---	----	--	---	-----------

Step 5) Determine the Lateral Trench Bottom Credited Width:

<p>Width of Trench bottom</p> <div style="border: 1px solid black; padding: 5px; width: fit-content; margin: 0 auto;">m (ft)</div> <p><i>The actual constructed width of the trench(es)</i></p>	X	<p>Conversion factor</p> <div style="border: 1px solid black; padding: 5px; width: fit-content; margin: 0 auto;"></div> <p><i>Use 1.1 for a gravity chamber system Use 1.3 for a pressure chamber system Use 1.1 for a pressure chamber system where pre-treatment is used Use 1.0 for all other field systems</i></p>	X	=	<p>Credited Width of Trench Bottom</p> <div style="border: 1px solid black; padding: 5px; width: fit-content; margin: 0 auto;">m (ft)</div> <p><i>To a maximum of 900 mm (3 ft)</i></p>	M5
--	----------	---	----------	----------	--	-----------

Step 6) Calculate the Required Length of lateral trench:

<p>Trench Bottom Area</p> <div style="border: 1px solid black; padding: 5px; width: fit-content; margin: 0 auto;">m² (ft²)</div> <p><i>From M4 above</i></p>	÷	<p>Credited Width of Trench Bottom</p> <div style="border: 1px solid black; padding: 5px; width: fit-content; margin: 0 auto;">m (ft)</div> <p><i>From M5 above</i></p>	÷	=	<p>Length of Lateral Trench Required</p> <div style="border: 1px solid black; padding: 5px; width: fit-content; margin: 0 auto;">m (ft)</div>	M6
---	----------	--	----------	----------	--	-----------

Step 7) Summarize the Information

Trench Bottom Area	<div style="border: 1px solid black; width: 50px; height: 20px;"></div>	From M4 in this worksheet
Actual Width of Lateral Trench or Chamber	<div style="border: 1px solid black; width: 50px; height: 20px;"></div>	From the first box of Step 5 in this worksheet
Credited Width of Lateral Trench Bottom	<div style="border: 1px solid black; width: 50px; height: 20px;"></div>	From M5 in this worksheet
Total Length of System	<div style="border: 1px solid black; width: 50px; height: 20px;"></div>	From M6 in this worksheet

*Appendix 17 should be used to size the pressure distribution system for a pressure absorption field. For a pressure chamber system, Appendix 3A can be used instead of utilizing Appendix 3 and 17.
Note: Additional requirements are present within the Guide that are not considered during the completion of this spreadsheet. The designer should ensure that all other sections are met.*

APPENDIX 3A – PRESSURE CHAMBER SYSTEM WORKSHEET

(Note: For Pressure Chamber Systems Appendix 3A can be completed in place of Appendix 3 and Appendix 17)

Step 1) You need to know:

- The daily sewage volume (size of dwelling served).
- The absorptive capacity of the soil where the chamber system will be located.

Expected Volume of Sewage per Day

L/day (gals/day)

M1

Step 2) Determine the total soil treatment area required.

First determine the soil loading rate using either a percolation test or the soil classification methods described in Section 14. The total treatment area can be calculated using either the formula on page XIV – 4 or by using Appendix 1. If using Appendix 1 match the perc. rate in the left column with the appropriate dwelling size in the top row. Ex. Perc. rate 7 (loamy sand) matched with a 3 bedroom house indicates a soil treatment area of 49.32 m² or 531.51 ft² is required.

Expected Volume of Sewage per Day

L/day (gals/day)

From M1 this worksheet.

÷

Soil Loading Rate

From calculation or Appendix 1.

=

Total Soil Treatment Area Required

m² (ft²)

M2

Step 3) Calculate the minimum required “trench bottom area”:

Total Soil Treatment Area Required

m² (ft²)

From M2 above

X

Pretreatment or Pressure Distribution Reduction Factor

(1-_____)

*A reduction of 30% can be applied where pretreatment is used (insert 0.30 in the blank space); or In all other cases, insert zero.
The local authority must approve all field size reductions.*

=

Required Trench Bottom Area

m² (ft²)

M3

Step 4) Calculate the minimum allowable infiltration area

Minimum Trench Bottom Size Allowed

37 m² (400 ft²)

37 m² (400 ft²) is the smallest trench bottom area allowable

OR

Required Trench Bottom Area

m² (ft²)

From M3 above

Trench Bottom Area

m² (ft²)

Maximum of the two previous boxes

M4

APPENDIX 3A – PRESSURE CHAMBER SYSTEM WORKSHEET

Step 5) Determine the Lateral Trench Bottom Credited Width:

<p>Width of Trench bottom</p> <div style="border: 1px solid black; width: 100%; height: 30px; display: flex; justify-content: flex-end; align-items: center; padding-right: 5px;">m (ft)</div> <p><i>The actual constructed width of the trench(es)</i></p>	X	<p>Conversion factor</p> <div style="border: 1px solid black; width: 100%; height: 30px;"></div> <p><i>Use 1.3 for a pressure chamber system where no pre-treatment is used Use 1.1 for a pressure chamber system where pre-treatment is used</i></p>	=	<p>Credited Width of Trench Bottom</p> <div style="border: 1px solid black; width: 100%; height: 30px; display: flex; justify-content: flex-end; align-items: center; padding-right: 5px;">m (ft)</div> <p><i>To a maximum of 900 mm (3 ft)</i></p>	M5
--	----------	--	----------	--	-----------

Step 6) Calculate the Required Length of lateral trench:

<p>Trench Bottom Area</p> <div style="border: 1px solid black; width: 100%; height: 30px; display: flex; justify-content: flex-end; align-items: center; padding-right: 5px;">m² (ft²)</div> <p><i>From M4 above</i></p>	÷	<p>Credited Width of Trench Bottom</p> <div style="border: 1px solid black; width: 100%; height: 30px; display: flex; justify-content: flex-end; align-items: center; padding-right: 5px;">m (ft)</div> <p><i>From M5 above</i></p>	=	<p>Total Length of Lateral Trench Required</p> <div style="border: 1px solid black; width: 100%; height: 30px; display: flex; justify-content: flex-end; align-items: center; padding-right: 5px;">m (ft)</div>	M6
---	----------	--	----------	--	-----------

Step 7) Determine the number of chambers required:

<p>Total Length of Lateral Trench Required</p> <div style="border: 1px solid black; width: 100%; height: 30px; display: flex; justify-content: flex-end; align-items: center; padding-right: 5px;">m (ft)</div> <p><i>From M6 this worksheet.</i></p>	÷	<p>Length of an Individual Chamber</p> <div style="border: 1px solid black; width: 100%; height: 30px; display: flex; justify-content: flex-end; align-items: center; padding-right: 5px;">m (ft)</div> <p><i>From manufacturer's information</i></p>	=	<p>Number of Chambers Required</p> <div style="border: 1px solid black; width: 100%; height: 30px;"></div>	M7
<p>Total Length of Lateral Trench Required</p> <div style="border: 1px solid black; width: 100%; height: 30px; display: flex; justify-content: flex-end; align-items: center; padding-right: 5px;"></div> <p><i>From M6 this worksheet.</i></p>	÷	<p>Number of Laterals Selected</p> <div style="border: 1px solid black; width: 100%; height: 30px;"></div> <p><i>Note: Total length of system could be divided into two or more laterals.</i></p>	=	<p>Length of a Single Lateral</p> <div style="border: 1px solid black; width: 100%; height: 30px; display: flex; justify-content: flex-end; align-items: center; padding-right: 5px;"></div> <p><i>Note: this result is only valid where each lateral is the same length.</i></p>	M8

Note: The chambers should be placed in at least two rows (laterals) and all laterals should be about the same length. The individual laterals should be no more than 30 metres (100 feet) long.

Step 8) Determine the Diameter of the Pressure Distribution Pipe, the Number of Orifices and the Diameter of the Orifices using Appendix 4. Match the length of pipe (of each lateral) required with a length in the left column and determine the most practical combination of orifices and orifice diameter for the each lateral in the system.

<p>Diameter of Pressure Distribution Pipe</p> <div style="border: 1px solid black; width: 100%; height: 30px; display: flex; justify-content: flex-end; align-items: center; padding-right: 5px;">cm (in)</div> <p>M9</p>	<p>Number of Orifices</p> <div style="border: 1px solid black; width: 100%; height: 30px;"></div> <p>M10</p>	<p>Diameter of Orifices</p> <div style="border: 1px solid black; width: 100%; height: 30px; display: flex; justify-content: flex-end; align-items: center; padding-right: 5px;">cm (in)</div> <p>M11</p>
---	--	--

APPENDIX 3A – PRESSURE CHAMBER SYSTEM WORKSHEET

Step 9) Determine the spacing of the orifices:

Length of a Single Pressure Distribution Lateral

m (ft)

M8 this worksheet

Number of Orifices

+ 1)

From M10 this worksheet.

Spacing of Orifices

= m (ft) **M12**

If laterals are of a different length, this step will have to be repeated for each lateral to obtain a total number of orifices.

Note: Close spacing of orifices provides effective, even distribution. 1 extra orifice should be included in the calculations because of the orifice at the start of the lateral. If laterals are of differing lengths, calculate each separately and add the number of orifices together.

Total Number of Orifices

M13

Total number of orifices (M13) equals M12 from this worksheet times the number of laterals.

Step 10) Use Appendix 5 to determine the total flow from all orifices. When working with this table use the row of numbers corresponding to Pressure Head Feet of 1.5 m (5.0 ft.)

Total Number of Orifices

x

From M13 this worksheet.

L/Min (gal/min) for each orifice

=

From Appendix 5.

Total Litres (gallons) per minute (Required from pump)

L/Min (gal/min) **M14**

Step 11) Use Appendix 6 to determine the type and size of effluent delivery pipe. This is the pipe from the pump to the farthest end of the header for the distribution laterals. A larger pipe will reduce pressure loss. A minimum flow rate as follows will help scour the pipe: 49 Lpm for 0.38 cm (13 gpm for 1 1/2"), 64 Lpm for 0.50 cm (17 gpm for 2"), 140 Lpm 0.76 cm (37 gpm for 3")

Pipe Type and Size Selected

cm (in) **M15**

APPENDIX 3A – PRESSURE CHAMBER SYSTEM WORKSHEET

Step 12) Calculate pressure loss due to pipe fittings. The pressure loss created by a fitting is equivalent to the pressure loss in a given length of straight pipe. Appendix 13 converts specific fittings to their corresponding pressure loss in terms of straight pipe.

Type of Fitting	Number of Fittings	Equivalent Length (ft) (for each fitting)	Total
Iron Pipe adapters			
Couplings and Tee fittings on the Run			
Elbows and Tee fittings Run to Branch			
Screen or filter if placed <u>after pump</u> – use manufacturer’s estimated pressure loss factor			
		Equivalent length of all fittings (for pressure loss)	<input type="text"/> M16

Step 13) Determine total length to be used to calculate Pressure Loss.

Length of Pressure Delivery Pipe

Equivalent Length of Fittings

Total Equivalent Length

+

=

 m (ft)

M17

Length of piping from pump to far end of header for the distribution laterals

From M16 this worksheet.

Step 14) Calculate pressure head loss in delivery pipe including fittings. Use Appendix 6 to determine the friction loss. Match the flow M13 (Step 10) in the left column with the appropriate type and size of pipe to determine the number to insert in box M18 below.

Total Equivalent Length

 m (ft)

From M17 this worksheet.

÷

100 =

 m (ft)

M18

 m (ft)

From M18 this worksheet.

x

Friction loss in m pressure head per 30.5 m (100 ft)

 M19

From Appendix 6

Delivery piping head loss

 m (ft) M20

M20

APPENDIX 3A – PRESSURE CHAMBER SYSTEM WORKSHEET

Step 15) Calculate the total pressure head required at pump.

Delivery piping pressure loss
m (ft)

M20

+

Lift distance of effluent from
low level in tank to orifices
m (ft)

Measured from lowest
effluent level in tank to
elevation of orifices

+

1.5 m (5 ft) squirt height
design pressure at orifices

+

Add 0.30 m (1 ft) to allow for
pressure loss along the
distribution lateral

Total pressure head
required at pump m (ft)

=

M21

Step 16) Detail the pump specifications required:

Required Flow Rate
(gal/min) **M14**

Required Pressure Head (ft) **M21**

@

If the flow rate through the orifices is too high: reduce the orifice diameter in Step 8, increase the orifice spacing or include a distributing valve to sequentially dose small portions of the system.

If the pressure head required is too high: select a lower design pressure, reduce the flow rate as above or increase the effluent delivery pipe size.

Don't forget that the effluent to a pressure distribution system should be screened.

Most pumps are rated in US gallons per minute. Be sure to select the pump in Imperial gallons per minute.

Conversion: US gallons X 0.83 = Imperial gallons or Imperial gallons X 1.2 = US gallons.

Note: Additional requirements are present within the Guide that are not considered during the completion of this spreadsheet. The designer should ensure that all other sections are met.

APPENDIX 4 - NUMBER OF ORIFICES IN A PRESSURE DISTRIBUTION LATERAL PIPE

Suitable for 600 mm (2 ft) to 1800 mm (6 ft) Pressure Head

Orifice Diameter NPS Pipe Size of Distribution Lateral Pipe			3.2mm (1/8")					4mm (5/32")				
			3/4"	1"	1-1/4"	1-1/2"	2"	3/4"	1"	1-1/4"	1-1/2"	2"
			19 mm	25 mm	32 mm	38 mm	51 mm	19 mm	25 mm	32 mm	38 mm	51 mm
Distribution Lateral Pipe Length		Minimum Number of Orifices	Maximum Number of Orifices					Maximum Number of Orifices				
10 ft	3 m	3	21	21	21	21	21	18	21	21	21	21
15 ft	4.6 m	4	23	31	31	31	31	15	31	31	31	31
20 ft	6.1 m	5	20	41	41	41	41	13	27	41	41	41
25 ft	7.6 m	6	17	37	51	51	51	11	24	43	51	51
30 ft	9.1 m	7	16	34	61	61	61	10	22	39	61	61
35 ft	10.7 m	8	15	31	56	71	71	9	20	36	58	71
40 ft	12.2 m	9	14	29	52	81	81	-	18	33	54	81
45 ft	13.7 m	10	13	27	49	79	91	-	17	31	50	91
50 ft	15.2 m	11	12	26	46	74	101	-	16	29	48	101
55 ft	16.8 m	12	-	24	44	71	111	-	16	28	45	96
60 ft	18.3 m	13	-	23	42	67	121	-	15	27	43	92
65 ft	19.8 m	14	-	22	40	64	131	-	-	26	41	88
70 ft	21.3 m	15	-	21	38	62	132	-	-	25	40	84
75 ft	22.9 m	16	-	21	37	60	127	-	-	24	38	81
80 ft	24.4 m	17	-	20	36	58	123	-	-	23	37	79
85 ft	25.9 m	18	-	19	35	56	119	-	-	22	36	76
90 ft	27.4 m	19	-	-	33	54	115	-	-	21	35	74
95 ft	29 m	20	-	-	32	52	112	-	-	21	34	72
100 ft	30.5	21	-	-	32	51	109	-	-	-	33	70
105 ft	32 m	22	-	-	31	50	106	-	-	-	32	68
110 ft	33.5 m	23	-	-	30	48	103	-	-	-	31	66
115 ft	35.1 m	24	-	-	29	47	101	-	-	-	30	65
120 ft	36.6 m	25	-	-	29	46	99	-	-	-	30	63
125 ft	38.1 m	26	-	-	28	45	96	-	-	-	29	62
130 ft	39.6 m	27	-	-	-	44	94	-	-	-	28	60
135 ft	41.1 m	28	-	-	-	43	92	-	-	-	-	59
140 ft	42.7 m	29	-	-	-	43	91	-	-	-	-	58
145 ft	44.2 m	30	-	-	-	42	89	-	-	-	-	57
150 ft	45.7 m	31	-	-	-	41	87	-	-	-	-	56
160 ft	48.8 m	33	-	-	-	40	84	-	-	-	-	54
170 ft	51.8 m	35	-	-	-	38	82	-	-	-	-	52
180 ft	54.9 m	37	-	-	-	-	79	-	-	-	-	51
190 ft	57.9 m	39	-	-	-	-	77	-	-	-	-	49
200 ft	61 m	41	-	-	-	-	75	-	-	-	-	48
225 ft	68.6 m	46	-	-	-	-	70	-	-	-	-	-
250 ft	76.2 m	51	-	-	-	-	66	-	-	-	-	-

APPENDIX 4 - NUMBER OF ORIFICES IN A PRESSURE DISTRIBUTION LATERAL PIPE

Suitable for 600 mm (2 ft) to 1800 mm (6 ft) Pressure Head

Orifice Diameter NPS Pipe Size of Distribution Lateral Pipe			4.8mm (3/16")					5.6mm (7/32")				
			3/4"	1"	1-1/4"	1-1/2"	2"	3/4"	1"	1-1/4"	1-1/2"	2"
			19	25	32	38	51	19	25	32	38	51
			mm	mm	mm	mm	mm	mm	mm	mm	mm	mm
Distribution Lateral Pipe Length		Minimum Number of Orifices	Maximum Number of Orifices					Maximum Number of Orifices				
10 ft	3 m	3	13	21	21	21	21	9	20	21	21	21
15 ft	4.6 m	4	10	22	31	31	31	8	16	29	31	31
20 ft	6.1 m	5	9	19	34	41	41	6	14	25	40	41
25 ft	7.6 m	6	8	17	30	48	51	-	12	22	35	51
30 ft	9.1 m	7	-	15	27	43	61	-	11	20	32	61
35 ft	10.7 m	8	-	14	25	40	71	-	10	18	29	63
40 ft	12.2 m	9	-	13	23	37	79	-	-	17	27	58
45 ft	13.7 m	10	-	12	22	35	74	-	-	16	26	55
50 ft	15.2 m	11	-	-	20	33	70	-	-	15	24	52
55 ft	16.8 m	12	-	-	19	31	67	-	-	14	23	49
60 ft	18.3 m	13	-	-	19	30	64	-	-	14	22	47
65 ft	19.8 m	14	-	-	18	29	61	-	-	-	21	45
70 ft	21.3 m	15	-	-	17	28	59	-	-	-	20	43
75 ft	22.9 m	16	-	-	-	27	56	-	-	-	19	42
80 ft	24.4 m	17	-	-	-	26	55	-	-	-	19	40
85 ft	25.9 m	18	-	-	-	25	53	-	-	-	-	39
90 ft	27.4 m	19	-	-	-	24	51	-	-	-	-	38
95 ft	29 m	20	-	-	-	23	50	-	-	-	-	37
100 ft	30.5	21	-	-	-	23	48	-	-	-	-	36
105 ft	32 m	22	-	-	-	-	47	-	-	-	-	35
110 ft	33.5 m	23	-	-	-	-	46	-	-	-	-	34
115 ft	35.1 m	24	-	-	-	-	45	-	-	-	-	33
120 ft	36.6 m	25	-	-	-	-	44	-	-	-	-	32
125 ft	38.1 m	26	-	-	-	-	43	-	-	-	-	31
130 ft	39.6 m	27	-	-	-	-	42	-	-	-	-	31
135 ft	41.1 m	28	-	-	-	-	41	-	-	-	-	30
140 ft	42.7 m	29	-	-	-	-	40	-	-	-	-	30
145 ft	44.2 m	30	-	-	-	-	40	-	-	-	-	-
150 ft	45.7 m	31	-	-	-	-	39	-	-	-	-	-
160 ft	48.8 m	33	-	-	-	-	38	-	-	-	-	-
170 ft	51.8 m	35	-	-	-	-	36	-	-	-	-	-
180 ft	54.9 m	37	-	-	-	-	-	-	-	-	-	-
190 ft	57.9 m	39	-	-	-	-	-	-	-	-	-	-
200 ft	61 m	41	-	-	-	-	-	-	-	-	-	-
225 ft	68.6 m	46	-	-	-	-	-	-	-	-	-	-
250 ft	76.2 m	51	-	-	-	-	-	-	-	-	-	-

APPENDIX 4 - NUMBER OF ORIFICES IN A PRESSURE DISTRIBUTION LATERAL PIPE

Suitable for 600 mm (2 ft) to 1800 mm (6 ft) Pressure Head

Orifice Diameter			6.4mm (1/4")					7.1mm (9/32")				
NPS Pipe Size of Distribution Lateral Pipe			3/4"	1"	1-1/4"	1-1/2"	2"	3/4"	1"	1-1/4"	1-1/2"	2"
			19	25	32	38	51	19	25	32	38	51
			mm	mm	mm	mm	mm	mm	mm	mm	mm	mm
Distribution Lateral Pipe Length	Minimum Number of Orifices		Maximum Number of Orifices					Maximum Number of Orifices				
10 ft	3 m	3	7	15	21	21	21	6	12	21	21	21
15 ft	4.6 m	4	6	12	22	31	31	5	10	17	28	31
20 ft	6.1 m	5	-	11	19	30	41	-	8	15	24	41
25 ft	7.6 m	6	-	9	17	27	51	-	7	13	21	45
30 ft	9.1 m	7	-	8	15	24	52	-	-	12	19	41
35 ft	10.7 m	8	-	-	14	23	48	-	-	11	18	38
40 ft	12.2 m	9	-	-	13	21	45	-	-	10	17	35
45 ft	13.7 m	10	-	-	12	20	42	-	-	-	16	33
50 ft	15.2 m	11	-	-	12	19	40	-	-	-	15	31
55 ft	16.8 m	12	-	-	-	18	38	-	-	-	14	30
60 ft	18.3 m	13	-	-	-	17	36	-	-	-	-	28
65 ft	19.8 m	14	-	-	-	16	34	-	-	-	-	27
70 ft	21.3 m	15	-	-	-	-	33	-	-	-	-	26
75 ft	22.9 m	16	-	-	-	-	32	-	-	-	-	25
80 ft	24.4 m	17	-	-	-	-	31	-	-	-	-	24
85 ft	25.9 m	18	-	-	-	-	30	-	-	-	-	23
90 ft	27.4 m	19	-	-	-	-	29	-	-	-	-	23
95 ft	29 m	20	-	-	-	-	28	-	-	-	-	22
100 ft	30.5	21	-	-	-	-	27	-	-	-	-	-
105 ft	32 m	22	-	-	-	-	26	-	-	-	-	-
110 ft	33.5 m	23	-	-	-	-	26	-	-	-	-	-
115 ft	35.1 m	24	-	-	-	-	25	-	-	-	-	-
120 ft	36.6 m	25	-	-	-	-	-	-	-	-	-	-
125 ft	38.1 m	26	-	-	-	-	-	-	-	-	-	-
130 ft	39.6 m	27	-	-	-	-	-	-	-	-	-	-
135 ft	41.1 m	28	-	-	-	-	-	-	-	-	-	-
140 ft	42.7 m	29	-	-	-	-	-	-	-	-	-	-
145 ft	44.2 m	30	-	-	-	-	-	-	-	-	-	-
150 ft	45.7 m	31	-	-	-	-	-	-	-	-	-	-
160 ft	48.8 m	33	-	-	-	-	-	-	-	-	-	-
170 ft	51.8 m	35	-	-	-	-	-	-	-	-	-	-
180 ft	54.9 m	37	-	-	-	-	-	-	-	-	-	-
190 ft	57.9 m	39	-	-	-	-	-	-	-	-	-	-
200 ft	61 m	41	-	-	-	-	-	-	-	-	-	-
225 ft	68.6 m	46	-	-	-	-	-	-	-	-	-	-
250 ft	76.2 m	51	-	-	-	-	-	-	-	-	-	-

**APPENDIX 4 - NUMBER OF ORIFICES IN A PRESSURE DISTRIBUTION
LATERAL PIPE**

Suitable for 600 mm (2 ft) to 1800 mm (6 ft) Pressure Head

ORIFICE DIAMETER			7.9mm (5/16")				
NPS Pipe Size of Distribution Lateral Pipe			3/4"	1"	1-1/4"	1-1/2"	2"
			19	25	32	38	51
			mm	mm	mm	mm	mm
Distribution Lateral Pipe Length		Minimum Number of Orifices	Maximum Number of Orifices				
10 ft	3 m	3	5	10	18	21	21
15 ft	4.6 m	4	-	8	14	23	31
20 ft	6.1 m	5	-	7	12	20	41
25 ft	7.6 m	6	-	-	11	17	37
30 ft	9.1 m	7	-	-	10	16	33
35 ft	10.7 m	8	-	-	9	14	31
40 ft	12.2 m	9	-	-	-	13	29
45 ft	13.7 m	10	-	-	-	13	27
50 ft	15.2 m	11	-	-	-	12	25
55 ft	16.8 m	12	-	-	-	-	24
60 ft	18.3 m	13	-	-	-	-	23
65 ft	19.8 m	14	-	-	-	-	22
70 ft	21.3 m	15	-	-	-	-	21
75 ft	22.9 m	16	-	-	-	-	20
80 ft	24.4 m	17	-	-	-	-	20
85 ft	25.9 m	18	-	-	-	-	19
90 ft	27.4 m	19	-	-	-	-	-
95 ft	29 m	20	-	-	-	-	-
100 ft	30.5	21	-	-	-	-	-
105 ft	32 m	22	-	-	-	-	-
110 ft	33.5 m	23	-	-	-	-	-
115 ft	35.1 m	24	-	-	-	-	-
120 ft	36.6 m	25	-	-	-	-	-
125 ft	38.1 m	26	-	-	-	-	-
130 ft	39.6 m	27	-	-	-	-	-
135 ft	41.1 m	28	-	-	-	-	-
140 ft	42.7 m	29	-	-	-	-	-
145 ft	44.2 m	30	-	-	-	-	-
150 ft	45.7 m	31	-	-	-	-	-
160 ft	48.8 m	33	-	-	-	-	-
170 ft	51.8 m	35	-	-	-	-	-
180 ft	54.9 m	37	-	-	-	-	-
190 ft	57.9 m	39	-	-	-	-	-
200 ft	61 m	41	-	-	-	-	-
225 ft	68.6 m	46	-	-	-	-	-
250 ft	76.2 m	51	-	-	-	-	-

APPENDIX 5 - ORIFICE DISCHARGES IN LITRES PER MINUTE

Pressure Head mm (ft.)	Orifice Diameter in mm								
	3.2 mm	4.0 mm	4.8 mm	5.6 mm	6.4 mm	7.1 mm	7.9 mm	8.7 mm	9.5 mm
600 mm	0.99	1.55	2.24	3.04	3.97	4.89	6.05	7.34	8.76
750 mm	1.11	1.74	2.50	3.40	4.44	5.47	6.77	8.21	9.79
900 mm	1.22	1.9	2.74	3.73	4.87	5.99	7.42	8.99	10.72
1050 mm	1.31	2.05	2.96	4.02	5.26	6.47	8.01	9.71	11.58
1200 mm	1.40	2.20	3.16	4.30	5.62	6.92	8.56	10.58	12.38
1350 mm	1.49	2.33	3.35	4.56	5.95	7.34	9.08	11.01	13.13
1500 mm	1.57	2.45	3.53	4.81	6.28	7.73	9.57	11.61	13.84
1800 mm	1.72	2.69	3.87	5.27	6.88	8.17	10.47	12.72	15.16
based on $q = 0.207Cd^2h^{1/2}$ where q = litres per minute flow rate C = coefficient of discharge (0.60) d = diameter in mm h = pressure head in metres									
Use A Minimum 600 mm (2 ft.) of Pressure Head .									
Orifice Discharges in Imperial Gallons per Minute									
Pressure Head Feet	Orifice Diameter in Inches								
	1/8	5/32	3/16	7/32	1/4	9/32	5/16	11/32	3/8
	0.125	0.1563	0.1875	0.2188	0.25	0.2813	0.3125	0.3438	0.375
2.0 ft	0.22	0.34	0.49	0.66	0.87	1.09	1.35	1.64	1.95
2.5 ft	0.24	0.38	0.55	0.75	0.98	1.23	1.52	1.84	2.19
3.0 ft	0.27	0.42	0.6	0.82	1.07	1.35	1.67	2.02	2.4
3.5 ft	0.29	0.45	0.65	0.88	1.15	1.45	1.8	2.17	2.59
4.0 ft	0.31	0.48	0.69	0.94	1.23	1.55	1.91	2.32	2.76
4.5 ft	0.33	0.51	0.73	1	1.3	1.64	2.03	2.46	2.93
5.0 ft	0.34	0.54	0.77	1.05	1.38	1.74	2.15	2.6	3.09
6.0 ft	0.37	0.59	0.85	1.16	1.52	1.91	2.37	2.86	3.4
Based on where	$q = 15.8 Cd^2h^{1/2}$ q = Imperial gallons per minute flow rate C = coefficient of discharge (0.60) d = diameter in inches h = pressure head in feet Use a minimum 2.0 ft of pressure head Note: Some pump manufacturers rate pump capacities in US gallons – must convert to imperial gallons								

APPENDIX 6 – FRICTION LOSS FOR PIPING

Friction Loss in Feet Pressure Head per 100 Feet in Schedule 40 PVC Pipe (C=150)													
Flow in Imp gpm	Nominal Pipe Diameter (in.)						Nominal Pipe Diameter (in.)						Flow in US gpm
	3/4	1	1 1/4	1 1/2	2	3	3/4	1	1 1/4	1 1/2	2	3	
1	0.37	0.11	0.03	0.01	-	-	0.26	0.08	0.02	0.01	-	-	1
2	1.27	0.39	0.1	0.05	0.01	-	0.91	0.28	0.07	0.03	0.01	-	2
3	2.69	0.83	0.22	0.1	0.03	-	1.92	0.59	0.16	0.07	0.02	-	3
4	4.59	1.42	0.37	0.18	0.05	0.01	3.27	1.01	0.27	0.13	0.04	0.01	4
5	6.93	2.14	0.56	0.27	0.08	0.01	4.95	1.53	0.4	0.19	0.06	0.01	5
6	9.71	3	0.79	0.37	0.11	0.02	6.93	2.14	0.56	0.27	0.08	0.01	6
7	12.92	3.99	1.05	0.5	0.15	0.02	9.22	2.85	0.75	0.35	0.11	0.02	7
8	16.54	5.11	1.35	0.64	0.19	0.03	11.8	3.65	0.96	0.45	0.13	0.02	8
9	20.56	6.35	1.67	0.79	0.23	0.03	14.67	4.53	1.19	0.56	0.17	0.02	9
10	24.99	7.72	2.03	0.96	0.28	0.04	17.83	5.51	1.45	0.69	0.2	0.03	10
11	29.8	9.21	2.42	1.15	0.34	0.05	21.27	6.57	1.73	0.82	0.24	0.04	11
12	35.01	10.82	2.85	1.35	0.4	0.06	24.99	7.72	2.03	0.96	0.28	0.04	12
13	40.6	12.54	3.3	1.56	0.46	0.07	28.97	8.95	2.36	1.11	0.33	0.05	13
14	-	14.38	3.79	1.79	0.53	0.08	33.23	10.27	2.7	1.28	0.38	0.06	14
15	-	16.34	4.3	2.03	0.6	0.09	37.76	11.66	3.07	1.45	0.43	0.06	15
16	-	18.42	4.85	2.29	0.68	0.1	42.54	13.14	3.46	1.63	0.48	0.07	16
17	-	20.6	5.42	2.56	0.76	0.11	-	14.7	3.87	1.83	0.54	0.08	17
18	-	22.9	6.03	2.85	0.84	0.13	-	16.34	4.3	2.03	0.6	0.09	18
19	-	25.31	6.66	3.15	0.93	0.14	-	18.06	4.76	2.25	0.67	0.1	19
20	-	27.83	7.33	3.46	1.03	0.15	-	19.86	5.23	2.47	0.73	0.11	20
25	-	42.05	11.07	5.23	1.55	0.23	-	30.01	7.9	3.73	1.11	0.16	25
30	-	-	15.51	7.33	2.17	0.32	-	42.05	11.07	5.23	1.55	0.23	30
35	-	-	20.63	9.75	2.89	0.43	-	-	14.73	6.96	2.06	0.31	35
40	-	-	26.42	12.48	3.7	0.55	-	-	18.85	8.91	2.64	0.39	40
45	-	-	32.85	15.52	4.6	0.68	-	-	23.44	11.07	3.28	0.49	45
50	-	-	39.92	18.85	5.59	0.83	-	-	28.49	13.46	3.99	0.59	50
55	-	-	-	22.49	6.67	0.99	-	-	33.98	16.05	4.76	0.71	55
60	-	-	-	26.42	7.83	1.16	-	-	39.92	18.85	5.59	0.83	60
65	-	-	-	30.64	9.08	1.35	-	-	-	21.86	6.48	0.96	65
70	-	-	-	35.14	10.42	1.55	-	-	-	25.08	7.44	1.1	70
75	--	-	-	39.92	11.84	1.76	-	-	-	28.49	8.45	1.25	75
80	-	-	-	-	13.34	1.98	-	-	-	32.1	9.52	1.41	80
85	-	-	-	-	14.92	2.22	-	-	-	35.91	10.65	1.58	85
90	-	-	-	-	16.58	2.46	-	-	-	39.92	11.84	1.76	90
95	-	-	-	-	18.33	2.72	-	-	-	-	13.08	1.94	95
100	-	-	-	-	20.15	2.99	-	-	-	-	14.38	2.14	100
125	-	-	-	-	30.45	4.54	-	-	-	-	21.73	3.23	125
150	-	-	-	-	42.67	6.34	-	-	-	-	30.45	4.52	150
175	-	-	-	-	-	8.43	-	-	-	-	40.5	6.07	175
200	-	-	-	-	-	10.79	-	-	-	-	-	7.7	200
250	-	-	-	-	-	16.3	-	-	-	-	-	11.63	250
300	-	-	-	-	-	22.84	-	-	-	-	-	16.3	300

APPENDIX 6 - FRICTION LOSS FOR PIPING

Friction Loss in mm Pressure Head per 30.5 Metres in Schedule 40 PVC Pipe (C=150)						
Flow	Nominal Pipe Diameter (in.)					
L/min	3/4	1	1 1/4	1 1/2	2	3
5	128	40	10	5	1	0
10	461	142	38	18	5	1
15	977	302	79	38	11	2
20	1,663	514	135	64	19	3
25	2,512	776	204	97	29	4
30	3,520	1,088	286	135	40	6
35	4,682	1,446	381	180	53	8
40	5,994	1,852	488	230	68	10
45	7,453	2,303	606	286	85	13
50	9,058	2,798	737	348	103	15
55	10,804	3,338	879	415	123	18
60	12,691	3,921	1,032	488	145	21
65	14,717	4,546	1,197	566	168	25
70	-	5,214	1,373	649	192	29
75	-	5,924	1,560	737	218	32
80	-	6,676	1,758	830	246	37
85	-	7,468	1,967	929	275	41
90	-	8,301	2,186	1,033	306	45
95	-	9,174	2,416	1,141	338	50
100	-	10,087	2,656	1,255	372	55
120	-	14,134	3,722	1,758	521	77
140	-	-	4,950	2,338	693	103
160	-	-	6,337	2,993	888	132
180	-	-	7,880	3,722	1,104	164
200	-	-	9,576	4,523	1,341	199
220	-	-	11,422	5,395	1,600	238
240	-	-	-	6,338	1,879	279
260	-	-	-	7,349	2,179	324
280	-	-	-	8,429	2,499	371
300	-	-	-	9,577	2,840	422
320	-	-	-	10,79	3,200	475
340	-	-	-	-	3,579	532
360	-	-	-	-	3,979	591
380	-	-	-	-	4,397	653
400	-	-	-	-	4,835	718
450	-	-	-	-	6,012	893
500	-	-	-	-	7,306	1,085
550	-	-	-	-	8,714	1,294
600	-	-	-	-	-	1,520
700	-	-	-	-	-	2,022
800	-	-	-	-	-	2,588
900	-	-	-	-	-	3,218

APPENDIX 6 - FRICTION LOSS FOR PIPING

Friction Loss in Feet Pressure Head per 100 Feet in Polyethylene Pipe (C=150)													
Flow in Imp gpm	Nominal Pipe Diameter (in.)						Nominal Pipe Diameter (in.)						Flow in US gpm
	3/4	1	1 1/4	1 1/2	2	3 3/4	1	1 1/4	1 1/2	2	3		
1	0.37	0.11	0.03	0.01	-	-	0.26	0.08	0.02	0.01	-	-	1
2	1.32	0.41	0.11	0.05	0.02	-	0.94	0.29	0.08	0.04	0.01	-	2
3	2.8	0.86	0.23	0.11	0.03	-	2.00	0.62	0.16	0.08	0.02	-	3
4	4.76	1.47	0.39	0.18	0.05	0.01	3.40	1.05	0.28	0.13	0.04	0.01	4
5	7.19	2.22	0.59	0.28	0.08	0.01	5.13	1.59	0.42	0.20	0.06	0.01	5
6	10.08	3.11	0.82	0.39	0.11	0.02	7.19	2.22	0.59	0.28	0.08	0.01	6
7	13.41	4.14	1.09	0.52	0.15	0.02	9.57	2.96	0.78	0.37	0.11	0.02	7
8	17.17	5.30	1.4	0.66	0.20	0.03	12.25	3.78	1.00	0.47	0.14	0.02	8
9	21.34	6.59	1.74	0.82	0.24	0.04	15.23	4.71	1.24	0.59	0.17	0.03	9
10	25.94	8.01	2.11	1.00	0.30	0.04	18.51	5.72	1.51	0.71	0.21	0.03	10
11	30.94	9.56	2.52	1.19	0.35	0.05	22.08	6.82	1.80	0.85	0.25	0.04	11
12	36.34	11.23	2.96	1.40	0.41	0.06	25.94	8.01	2.11	1.00	0.30	0.04	12
13	42.14	13.02	3.43	1.62	0.48	0.07	30.08	9.29	2.45	1.16	0.34	0.05	13
14	-	14.93	3.93	1.86	0.55	0.08	34.50	10.66	2.81	1.33	0.39	0.06	14
15	-	16.97	4.47	2.11	0.63	0.09	39.19	12.11	3.19	1.51	0.45	0.07	15
16	-	19.12	5.03	2.38	0.71	0.10	44.16	13.64	3.59	1.70	0.50	0.07	16
17	-	21.39	5.63	2.66	0.79	0.12	-	15.26	4.02	1.90	0.56	0.08	17
18	-	23.77	6.26	2.96	0.88	0.13	-	16.97	4.47	2.11	0.63	0.09	18
19	-	26.27	6.92	3.27	0.97	0.14	-	18.75	4.94	2.33	0.69	0.10	19
20	-	28.89	7.61	3.59	1.07	0.16	-	20.62	5.43	2.56	0.76	0.11	20
25	-	43.65	11.49	5.43	1.61	0.24	-	31.15	8.20	3.87	1.15	0.17	25
30	-	-	16.11	7.61	2.26	0.33	-	43.65	11.49	5.43	1.61	0.24	30
35	-	-	21.42	10.12	3.00	0.45	-	-	15.29	7.22	2.14	0.32	35
40	-	-	27.42	12.95	3.84	0.57	-	-	19.57	9.24	2.74	0.41	40
45	-	-	34.1	16.11	4.78	0.71	-	-	24.34	11.50	3.41	0.51	45
50	-	-	41.44	19.57	5.80	0.86	-	-	29.57	13.97	4.14	0.62	50
55	-	-	-	23.35	6.92	1.03	-	-	35.28	16.66	4.94	0.73	55
60	-	-	-	27.42	8.13	1.21	-	-	41.44	19.57	5.80	0.86	60
65	-	-	-	31.80	9.43	1.40	-	-	-	22.70	6.73	1.00	65
70	-	-	-	36.47	10.81	1.61	-	-	-	26.03	7.72	1.15	70
75	-	-	-	41.44	12.29	1.82	-	-	-	29.58	8.77	1.30	75
80	-	-	-	-	13.85	2.06	-	-	-	33.33	9.88	1.47	80
85	-	-	-	-	15.49	2.30	-	-	-	37.28	11.05	1.64	85
90	-	-	-	-	17.22	2.46	-	-	-	41.44	12.29	1.82	90
95	-	-	-	-	19.03	2.83	-	-	-	-	13.58	2.02	95
100	-	-	-	-	20.92	3.11	-	-	-	-	14.93	2.22	100
125	-	-	-	-	31.61	4.69	-	-	-	-	22.56	3.35	125
150	-	-	-	-	44.29	6.58	-	-	-	-	31.61	4.69	150
175	-	-	-	-	-	8.75	-	-	-	-	42.05	6.24	175
200	-	-	-	-	-	11.20	-	-	-	-	-	7.99	200
250	-	-	-	-	-	16.92	-	-	-	-	-	12.08	250
300	-	-	-	-	-	23.71	-	-	-	-	-	16.92	300

APPENDIX 6 – FRICTION LOSS FOR PIPING

Friction Loss in mm Pressure Head per 30.5 Metres in Polyethylene Pipe, Carlon = 147						
Flow L/min.	Nominal Pipe Diameter (in.)					
	3/4	1	1 1/4	1 1/2	2	3
5	133	41	11	5	2	0
10	479	148	39	18	5	1
15	1,014	313	82	39	12	2
20	1,726	533	140	66	20	3
25	2,608	806	212	100	30	4
30	3,654	1,129	297	140	42	6
35	4,860	1,502	395	187	55	8
40	6,222	1,922	506	239	71	11
45	7,737	2,390	629	297	88	13
50	9,402	2,905	765	361	107	16
55	11,215	3,465	912	431	128	19
60	13,174	4,070	1,072	506	150	22
65	15,277	4,720	1,243	587	174	26
70	-	5,413	1,425	673	200	30
75	-	6,150	1,619	765	227	34
80	-	6,930	1,825	862	256	38
85	-	7,752	2,041	964	286	42
90	-	8,617	2,269	1,072	318	47
95	-	9,524	2,508	1,185	351	52
100	-	10,471	2,757	1,303	386	57
120	-	14,672	3,864	1,825	541	80
140	-	-	5,139	2,427	720	107
160	-	-	6,579	3,107	921	137
180	-	-	8,180	3,864	1,146	170
200	-	-	9,941	4,696	1,392	207
220	-	-	11,857	5,601	1,661	247
240	-	-	-	6,579	1,951	290
260	-	-	-	7,629	2,262	336
280	-	-	-	8,750	2,594	385
300	-	-	-	9,942	2,948	438
320	-	-	-	11,202	3,321	493
340	-	-	-	-	3,716	552
360	-	-	-	-	4,130	613
380	-	-	-	-	4,565	678
400	-	-	-	-	5,019	745
450	-	-	-	-	6,241	927
500	-	-	-	-	7,584	1,126
550	-	-	-	-	9,046	1,343
600	-	-	-	-	-	1,578
700	-	-	-	-	-	2,099
800	-	-	-	-	-	2,687
900	-	-	-	-	-	3,341

APPENDIX 7 – TYPE II MOUND: AREA SIZING

This worksheet is for use to: size the sand layer, mound base area and berm dimensions as required in the construction of a Type II mound.
It can be used for the design of a Type II mound.

Use only Imperial units of measurement throughout.

Use the following Worksheet to determine the minimum required dimensions for a Type II mound and fill in the blanks on the appropriate diagram below for a level site or a sloping site of over 1%.

TYPE II MOUND DIMENSIONS

LEVEL SITE

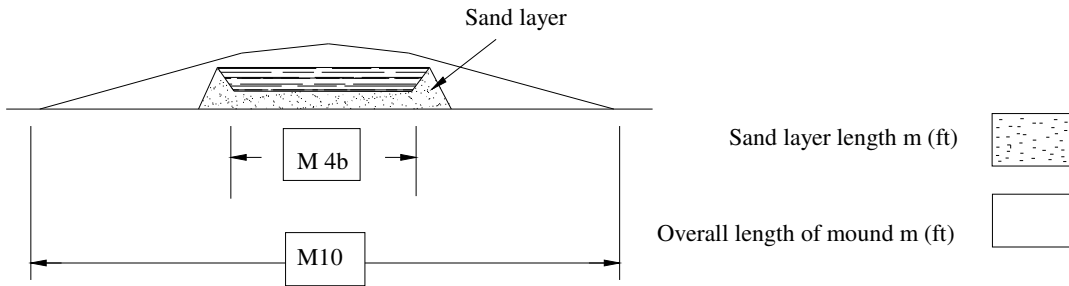

SLOPING SITE

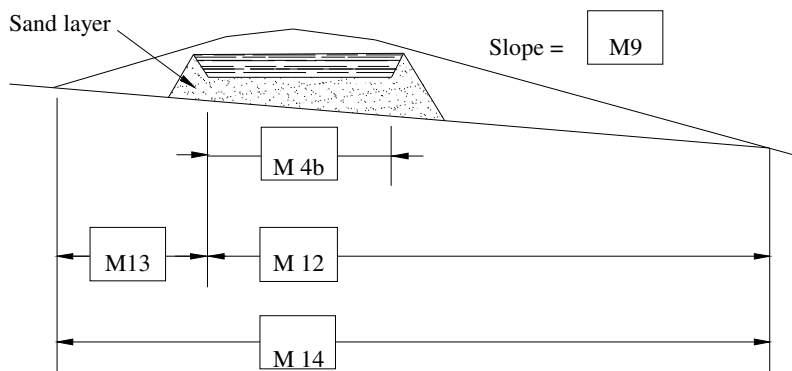

APPENDIX 7 – TYPE II MOUND: AREA SIZING

WORKSHEET 1 – TYPE II MOUND

Step 1) Determine the expected volume of sewage per day:

Note: Use Appendix 2 as a guide to determine expected volume of sewage per day. Provide allowance for additional load factors.

Assure that the sewage strength does not exceed the requirements of Residential Strength Sewage.

Expected Volume of Sewage per Day

L/day (gal/day) **M1**

Step 2) Calculate the treatment area of the sand layer:

Expected Volume of Sewage per Day

Sand Layer Effluent Loading Rate

Treatment Area Required For Sand Layer

m³ (gal)

÷

50 L/ m² (or 1 gal/ft²) per day

=

m² (ft²) **M2**

From **M1** this worksheet.

Step 3) Determine the minimum allowable sand layer area:

Minimum Sand Layer

Area of Sand Layer for Treatment

Area of Sand Layer

37.16 m² (400 ft²)

or

m² (ft²)

m² (ft²) **M3**

The minimum area of the sand Layer is 37.16 m² (400 ft²).

From **M2** this worksheet.

The greater of 37.16 m² (400 ft²) or **M2**.

Step 4) Calculate the length of the sand layer:

Area of Sand Layer

Width of Sand Layer

Length of Sand Layer

m² (ft²)

÷

m (ft)

=

m (ft) **M4**

M4a
From **M3** this worksheet.

M4b
Select a width to a Maximum of 3 m (10 ft).

Note: The width of the sand layer will influence the total width of the Type II mound and the amount of fill material required. The lowest cost configuration is often to make the sand layer as wide as allowed, however, on sloping sites, a narrower and longer sand layer design can reduce the amount of fill required. See Table A.15

APPENDIX 7 – TYPE II MOUND: AREA SIZING

Step 5) Determine the (design) soil effluent loading rate:

Soil Effluent Loading Rate

Note: Effluent loading rate can be determined from soil texture Classification *or* from percolation test results according to Appendix 8. Appendix 1 provides the effluent loading rates for soils between 5 and 120 minutes per inch perc rates.

L/m² (gal/ft²) per day

M5

Step 6) Calculate the preliminary infiltration area of soil before area reduction factors:

<p>Expected Volume of Sewage per Day</p> <div style="border: 1px solid black; padding: 5px; width: 100px; margin: 0 auto;">L/day (gal/day)</div> <p><i>From M1 this worksheet.</i></p>	÷	<p>Soil Effluent Loading Rate</p> <div style="border: 1px solid black; padding: 5px; width: 100px; margin: 0 auto;">L/m² (gal/ft²) per day</div> <p><i>From M5 this worksheet.</i></p>	=	<p>Preliminary Infiltration Area</p> <div style="border: 1px solid black; padding: 5px; width: 100px; margin: 0 auto;">m² (ft²)</div> <p><i>(Required for Soil. Before Reduction Factors.)</i></p>
--	---	--	---	--

M6

Step 7) Calculate the required infiltration area including allowed area reduction factors:

<p>Infiltration Area Required for Soil</p> <div style="border: 1px solid black; padding: 5px; width: 100px; margin: 0 auto;">m² (ft²)</div> <p><i>(Before Reduction Factors.) From M6 this worksheet.</i></p>	X	<p>Reduced Area Factor</p> <div style="border: 1px solid black; padding: 5px; width: 100px; margin: 0 auto;">0.7</div> <p><i>A reduction of up to 30% (1 – 0.70) can be applied to Type II mounds.</i></p>	=	<p>Required Infiltration Area</p> <div style="border: 1px solid black; padding: 5px; width: 100px; margin: 0 auto;">m² (ft²)</div> <p><i>(Including Reduction Factors.)</i></p>
---	---	--	---	---

M7

APPENDIX 7 – TYPE II MOUND: AREA SIZING

Step 8) Calculate the required width of the infiltration area:

<p>Required Infiltration Area</p> <div style="border: 1px solid black; padding: 5px; width: 150px; margin: 5px auto; text-align: center;"> m² (ft²) </div> <p style="font-size: 0.8em; margin-top: 5px;">(Including Reduction Factors.) From M7 this worksheet.</p>	\div	<p>Length of Sand Layer</p> <div style="border: 1px solid black; padding: 5px; width: 150px; margin: 5px auto; text-align: center;"> m (ft) </div> <p style="font-size: 0.8em; margin-top: 5px;">From M4 this worksheet.</p>	$=$	<p>Width of Required Infiltration Area</p> <div style="border: 1px solid black; padding: 5px; width: 150px; margin: 5px auto; text-align: center;"> m (ft) </div> <p style="font-size: 1.5em; margin-top: 5px; text-align: right;">M8</p>
---	--------	--	-----	---

Step 9) Determine the slope criteria of the installation site:

*If the slope of the installation site exceeds 1%, proceed to Step 12.
If the slope is 1% or less, proceed to Step 10.*

Slope of Installation Site

%

M9

Note: The following calculations apply ONLY to the minimum height configuration of a mound. If it is necessary to raise the sand layer, (for example to provide clearance to the water table) the following calculations are NOT adequate for the design.

For slopes of 1% or Less, Use Steps 10 to 11

Step 10) Determine the toe to toe width of the mound:

<p>Toe to Toe Width Based on 4:1 Slope Requirement</p> <div style="border: 1px solid black; padding: 5px; width: 150px; margin: 5px auto; text-align: center;"> m (ft) </div> <p style="font-size: 0.8em; margin-top: 5px; text-align: center;">M10a 4:1 Slope Requirement Refer to Berm Dimensions Diagram this Worksheet, or determine by calculation.</p>	<p style="font-size: 1.5em;">or</p>	<p>Width of Required Infiltration Area Within Berms</p> <div style="border: 1px solid black; padding: 5px; width: 150px; margin: 5px auto; text-align: center;"> m (ft) </div> <p style="font-size: 0.8em; margin-top: 5px; text-align: center;">M10b From M8 this worksheet.</p>	$=$	<p>Toe to Toe Width of Mound</p> <div style="border: 1px solid black; padding: 5px; width: 150px; margin: 5px auto; text-align: center;"> m (ft) </div> <p style="font-size: 1.5em; margin-top: 5px; text-align: right;">M10 <i>The greater of M10a or M10b.</i></p>
--	--	--	-----	--

Step 11) Proceed to Step 16:

Steps 12 to 15 are used only for installations where the slope exceeds 1%.

APPENDIX 7 – TYPE II MOUND: AREA SIZING

For Slopes Exceeding 1%, Use Steps 12 to 15

Step 12) Determine the width of the sand layer plus downslope berm:

The width of the mound is based on the **greater of**:

- the width as determined by the 4:1 slope requirement, **or**
- the width required to provide adequate infiltration area.

Downslope Berm Width Based on 4:1 Slope Requirement Plus Width of Sand Layer

Downslope Berm Width at 4:1 m (ft)

M12a
Refer to *Berm Dimensions Diagram* this worksheet.

+

Sand Layer Width m (ft)

M12b
From **M4b** worksheet.

m (ft)

M12c
4:1 Slope Requirement.

or

Width Required Infiltration Area Under Sand Layer And Downslope Berm

m (ft)

M12d
From **M8** to this worksheet.

Width of Sand Layer And Downslope Berm

m (ft)

The greater of **M12c** or **M12d**.

M12

Step 13) Determine the width of the upslope berm:

Width Based on 4:1 Slope Requirement
Refer to *Berm Dimensions Diagram* this worksheet, or determine by calculation.

Width of Upslope Berm

m (ft)

M13

Step 14) Determine the toe to toe width of the mound:

Width of Sand Layer and Downslope Berm

m (ft)

From **M12** this worksheet.

+

Width of Upslope Berm

m (ft)

From **M13** this worksheet.

=

Toe to Toe Width of Mound

m (ft)

M10

Step 15) Proceed to Step 16:

APPENDIX 7 – TYPE II MOUND: AREA SIZING

Step 16) Summarize the information:

Width of Sand Layer (from **M4b** this worksheet)

 m (ft)

Length of Sand Layer (from **M4** this worksheet)

 m (ft)

Slope of Installation Site (from **M9** this worksheet)

 %

Toe to Toe Width of Mound (from **M10** or **M14** this worksheet)

 m (ft)

Step 17) Complete the berm diagram dimensions on first page.

Fill in the appropriate diagram on the first page with the numbers calculated in this worksheet.

Step 18) Confirm the design complies with the Guide.

*This worksheet does NOT consider all the requirements of the Guide.
Please work safely and follow safe practices near trenches and open excavations.*

APPENDIX 7 – TYPE II MOUND: AREA SIZING

**TYPE II MOUND BERM
DIMENSIONS ON SLOPES**

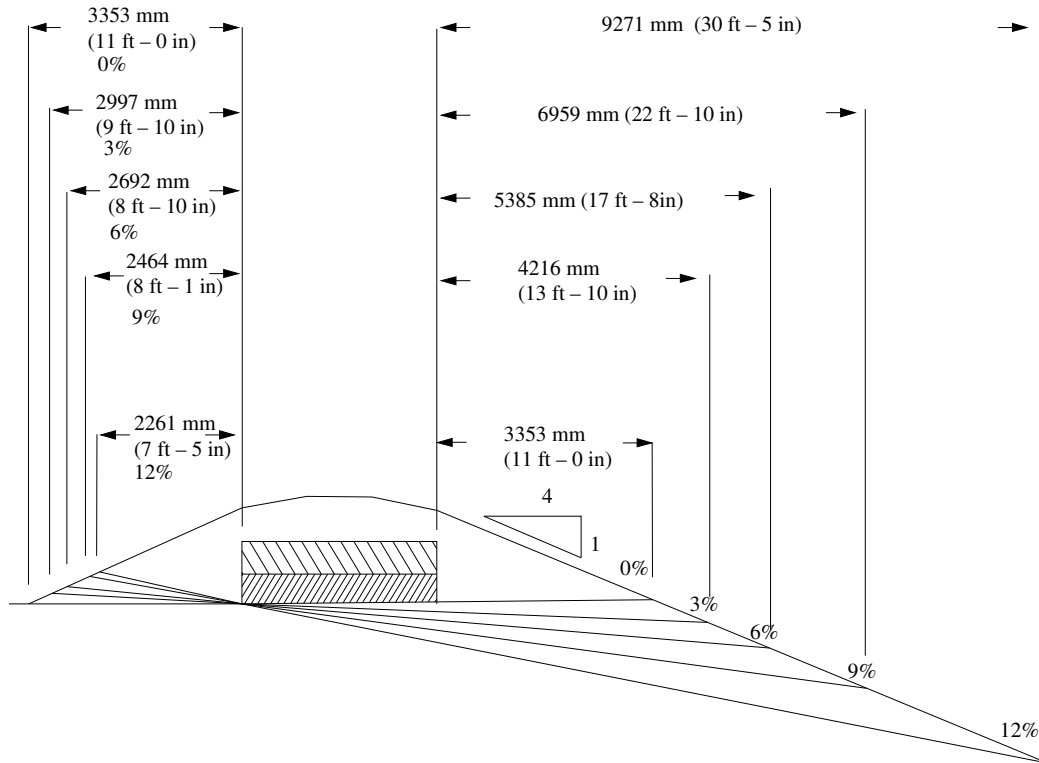

This diagram is based on a Minimum Mound Height, 1048 mm (10.00 ft) wide Sand Layer, and a Minimum Berm Slope of 4:1

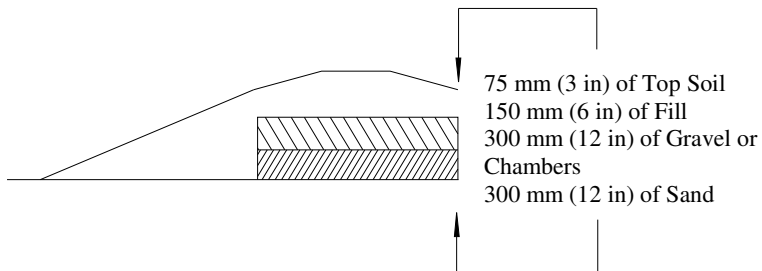

838 mm (33 in) Minimum Height at the Side of the Sand Layer

APPENDIX 7A – TYPE I MOUND: AREA SIZING WORKSHEET

Step 1) You need to know:

- The daily sewage volume (size of dwelling served).
- The absorptive capacity of the soil where the system will be located.

Expected Volume of Sewage per Day

L/day (gals/day)

G1

Step 2) Determine the total soil treatment area required.

The soil loading rate can be determined from the soil texture classification (Appendix 15) or from percolation test results. If using the percolation test, Appendix 1, which provides the effluent loading rates for soils between 5 and 120 minutes per inch, shows the perc. rate in the left column with the appropriate dwelling size in the top row. Ex. Perc. rate 7 (loamy sand) matched with a 3 bedroom house indicates a soil treatment area of 49.32 m² or 531.51 ft² is required.

Expected Volume of Sewage per Day

L/day (gals/day)

From G1 this worksheet.

÷

Soil Loading Rate

From calculation, Appendix 15 or Appendix 1.

=

Total Soil Treatment Area Required

m² (ft²)

G2

Step 3) Calculate the required volume of clean graded stone:

Total Soil Treatment Area Required

m² (ft²)

From G2 above

X

Total Depth of Clean Graded Stone

0.45 m (1.5 ft)

=

Total Volume of Clean Graded Stone Required

m³ (ft³)

G3

Step 4) Calculate the length of the system

Total Soil Treatment Area Required

m² (ft²)

From G2 above

÷

Selected Width of Type I mound

m (ft)

*Maximum width is 3 m (10 ft)
Site conditions may require a narrower mound.*

=

Length of Mound

m (ft)

G4

APPENDIX 7A – TYPE I MOUND: AREA SIZING WORKSHEET

Step 5) Summarize the Information

**Total Soil Treatment Area
Required**

From **G2** in this worksheet

Width of Mound

From the second box of
Step 4 in this worksheet

Length of Mound

From **G4** in this worksheet

**Total Volume of Clean
Graded Stone Required**

From **G3** in this worksheet

APPENDIX 8 - HOW TO CONDUCT A PERCOLATION TEST

Tools Needed

- ❑ shovel or post hole digger
- ❑ flash light
- ❑ 1.2 m (5 ft) long pole, with clearly marked lengths of 12.5 cm (5 in) and 15 cm (6 in) from the bottom
- ❑ permanent marking pen
- ❑ garden hose or pail to fill hole with water
- ❑ reporting form and pen
- ❑ lawn chair

Method

1. Percolation test holes should be made at points and elevations selected as typical in the area of the proposed absorption field.
2. Test holes should be dug at each end of the area of the absorption field to a minimum depth of 0.9 m (3 ft) and must be 20 cm (8 in) in diameter. Further holes may be required, depending upon the nature of the soil, the results of the first tests and the size of the proposed absorption field.

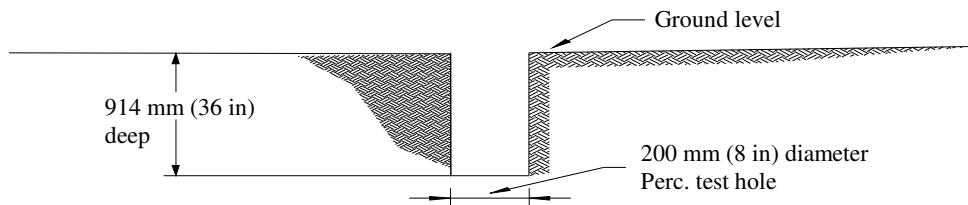

3. To make the percolation test more accurate, any smeared soil should be removed from the walls of the test holes.
4. If the soil contains considerable amounts of silt or clay, the test holes must be pre-soaked before proceeding with the test. Pre-soaking is accomplished by keeping the hole filled with water for 4 hours or more. The test must be carried out immediately after pre-soaking.
5. To undertake the test, fill the test hole with water twice. When the water level is 12.5 cm (5 in) or less from the bottom of the hole, refill the hole to the top. No recording of time need be done for these 2 fillings.

APPENDIX 8 - HOW TO CONDUCT A PERCOLATION TEST

6. After the second filling, when the water level is 12.5 cm (5 in) or less from the bottom of the hole, add enough water to bring the depth of water to 15 cm (6 in) or more.

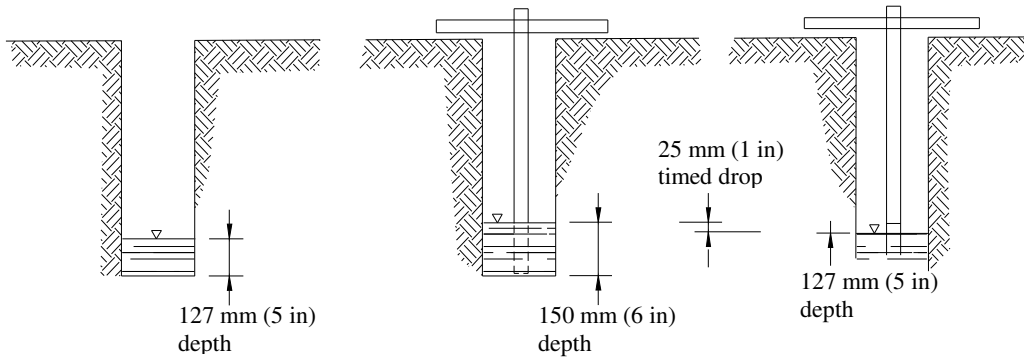

7. Observe the water level until it drops to the 15 cm (6 in) depth. At precisely 15 cm (6 in), commence timing. When the water level reaches the 12.5 (5 in) depth, stop timing, record the time in minutes.
8. Repeat procedures 6 & 7 until they do not vary by more than 2 minutes per 2.5 cm (1 in).
9. Record and report all rates of fall in minutes per cm. Determine the percolation rate for the proposed sewage disposal system by averaging the slowest rate determined for each of the test holes.
10. Leave the excavated material for inspection, cover the test holes with other suitable dirt and flag the test hole locations.

APPENDIX 9 – PROCEDURE FOR HAND TEXTURING A SOIL SAMPLE

Procedure for Hand Texturing a Soil Sample

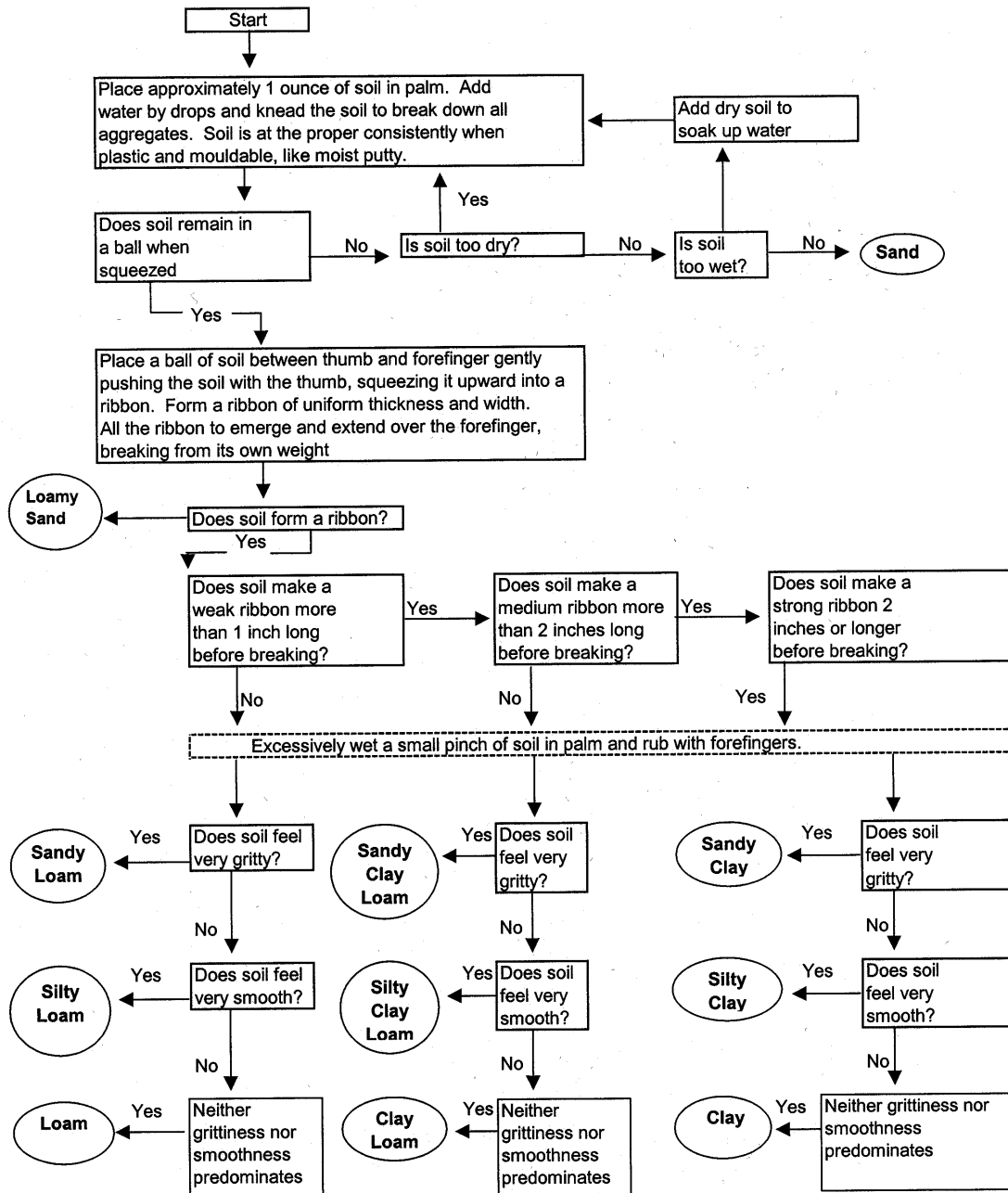

APPENDIX 10 - REPORT FORM - PERCOLATION TEST

Name(s) _____

Legal Address
(lot, block, plan etc.) _____

Mailing Address _____

Lot Size (acres/sq metres) _____ **House Size (sq metres)** _____

Number of Bedrooms _____ **Normal Occupancy** _____

Soil Conditions (see Soil Tests Section) _____

Percolation Test #1 _____ **Percolation Test #2** _____

Test #1 + Test #2 divided by 2 = Average Percolation Test

APPENDIX 11 – CONVERSION FACTORS

1 pound = 0.45359 kilograms	1 cubic decimeter = 0.0353 cubic ft
1 kilogram = 2.2046 pounds	1 litre = 0.0353 cubic ft
1 inch = 2.540 centimetres	1 cubic metre = 1.308 cubic yards
1 foot = 0.3048 metres	1 cubic metre = 35.3 cubic ft
1 yard = 0.9144 metres	1 cubic metre = 220 Imperial gals
1 yard = 36.00 inches	1 cubic metre = 1000 litres
1 mile = 1.609 kilometres	1 Imperial gals = 4.546 litres
1 centimetre = 0.3937 inches	1 Imperial gals = 277.42 cubic inches
1 metre = 3.281 ft	1 Imperial gals of water = 10 lbs
1 metre = 1.094 yards	1 Imperial gals per sq. ft. = 49 litres per square metre
1 metre = 39.37 inches	1 Imperial gals = 1.20 U.S. gals
1 kilometre = 0.6214 miles	1 litre = 0.220 Imperial gals
1 square inch = 6.452 square centimetres	1 litre per sq metre = 0.020 Imperial gals per square foot
1 square foot = 0.093 square metres	1 U.S. gals = 3.785 litres
1 square yard = 0.836 square metres	1 U.S. gals = 231 cubic inches
1 acre = 0.405 hectares	1 U.S. gals = 0.83 Imperial gals
1 square mile = 259 hectares	1 litre = 0.264 U.S. gals.
1 square mile = 2.59 square kilometres	1 foot pressure head = 304.8 mm pressure head
1 square centimetre = 0.155 sq inches	1 foot pressure head = 0.434 psi
1 square metre = 10.765 square ft	1 psi = 2.301 ft pressure head
1 square metre = 1.196 square yards	1 psi = 6.894757 kPa
1 hectare = 2.471 acres	1 kPa = 0.145037 psi
1 hectare = 10,000 square metres	1,000 mm pressure head = 9.807 kPa
1 square kilometre = 0.386 square miles	1 kPa = 102 mm pressure head
1 cubic inch = 16.387 cubic centimetres	1 kPa = 0.335 feet pressure head
1 cubic foot = 28,317 cubic centimetres	
1 cubic foot = 6.23 Imperial gals	
1 cubic foot = 28.3 litres	
1 cubic yard = 0.765 cubic metres	
1 cubic yard = 168 Imp gals	
1 cubic yard = 765 litres	
1 cubic centimetre = 0.06102 cubic inches	

APPENDIX 12 – SQUIRT TEST

The squirt test may be useful in the testing or providing the design of pressure distribution systems for treatment mounds and other pressure distribution applications

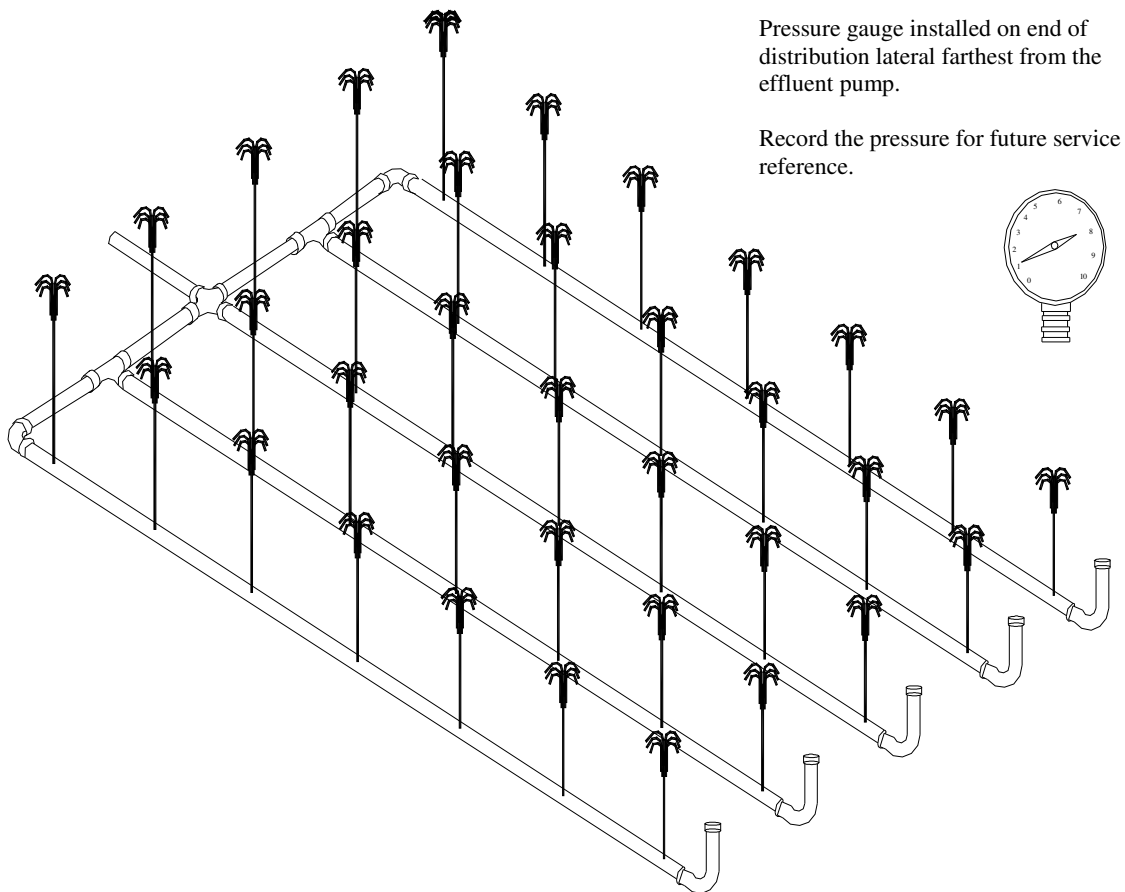

Pressure gauge installed on end of distribution lateral farthest from the effluent pump.

Record the pressure for future service reference.



Squirt height should be a minimum 1.5 m (5 ft) in all distribution laterals for a disposal field. Squirt height in a treatment mound is a minimum of 600 mm (24 in).

Squirt height should not exceed a 20% loss in squirt height at the end of any distribution laterals in distribution system.

If 20% loss in squirt height is not exceeded, a 10% variation in volume will not be exceeded.

APPENDIX 13 - FRICTION LOSS FOR INSERT FITTINGS

Pressure Loss Equivalent Lengths for Polyethylene Piping Insert Fittings Expressed in Approximate Length of Straight Pipe						
Pipe Size (in.)	Iron Pipe Adapters		Couplings and Tee Fittings on the Run		Elbows and Tee Fittings Run to Branch	
	Feet	Metres	Feet	Metres	Feet	Metres
1/2	1	0.30	0.50	0.15	3.00	0.91
3/4	1.5	0.46	0.75	0.23	4.3	1.31
1	2	0.61	1	0.30	6	1.83
1 1/4	2.7	0.82	1.3	0.40	8.6	2.62
1 1/2	3.4	1.04	1.6	0.49	10.5	3.20
2	4.4	1.34	2	0.61	13.2	4.02
3	6.2	1.89	2.9	0.88	17	5.18

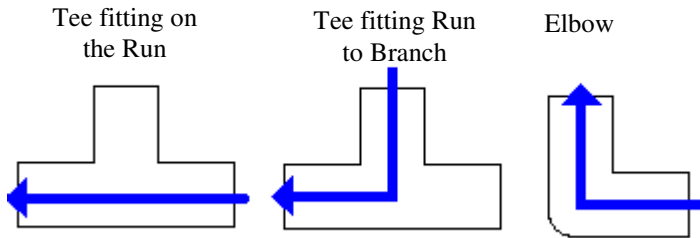

Note: The following formula was used to calculate pressure head loss in Appendix 6
Friction loss in feet of pressure head is equal to:

$$\text{Length of pipe} = \left\{ \frac{3.55 \times (\text{Imp gpm flow} \times 1.2)}{\text{coefficient} \times \text{dia.}^{2.63}} \right\}^{1.85}$$

Coefficients:

- PVC 150
- Polyethylene 147

LIQUID VOLUME OF VARIOUS SIZES OF PLASTIC PIPES				
Nominal Pipe Diameter	Inside Diameter		Volume (per 100 feet of pipe)	
	mm	inches	liters	Imp Gallons
1	26.65	1.049	17	3.74
1 1/4	35.10	1.380	30	6.48
1 1/2	40.89	1.61	40	8.82
2	52.5	2.067	66	14.66
3	77.93	3.068	145	30.0
4	102.26	4.026	250	55.1

APPENDIX 14 – DISTRIBUTION BOX**DEFINITION**

A distribution box is a device used for ensuring that effluent from a septic tank or treatment plant is distributed in equal amounts to each line of a distribution system.

Distribution boxes are commonly used in the Type I Mound systems, Chamber systems, and Absorption Field systems.

FUNCTION

The distribution box regulates and distributes the flow of effluent from the septic tank into the distribution pipes. Equal distribution is necessary to prevent one distribution line from becoming overloaded while others remain unused.

DESIGN

The distribution box must be watertight, rigidly constructed, and fitted with a durable watertight cover. Commercial distribution boxes are available and are approved for use in Saskatchewan.

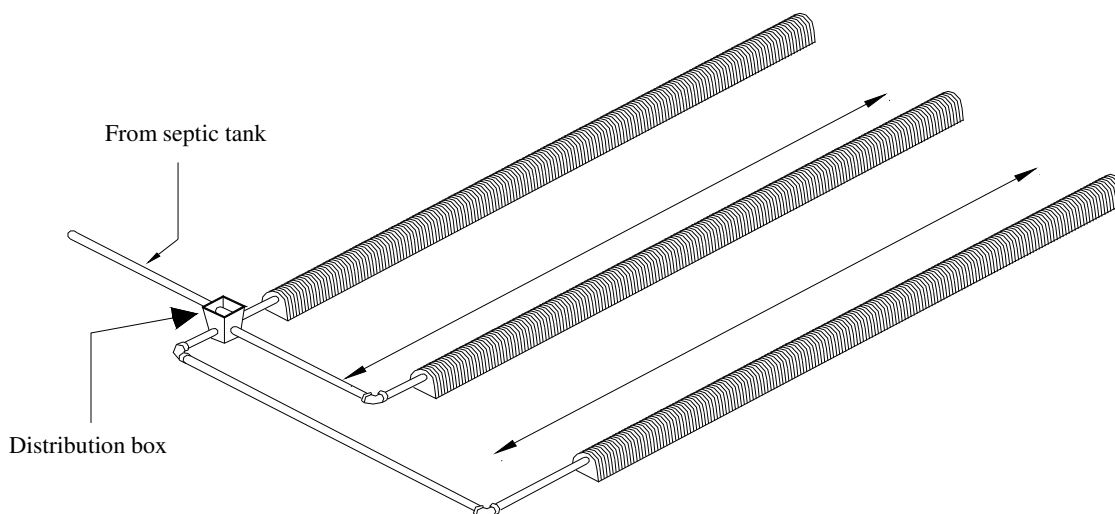
Typical Disposal Field using a Distribution Box

APPENDIX 14 – DISTRIBUTION BOX

Distribution boxes may be circular or rectangular depending on the manufacturer. An example of a distribution box is listed below.

Examples of distribution box

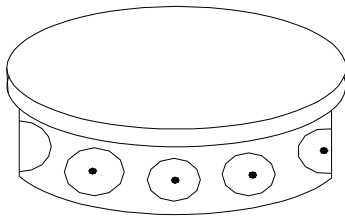

High impact strength removable cover suitable in pump and gravity system

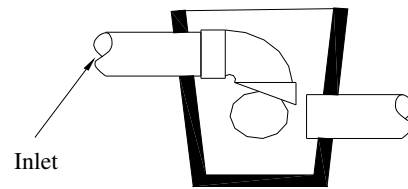
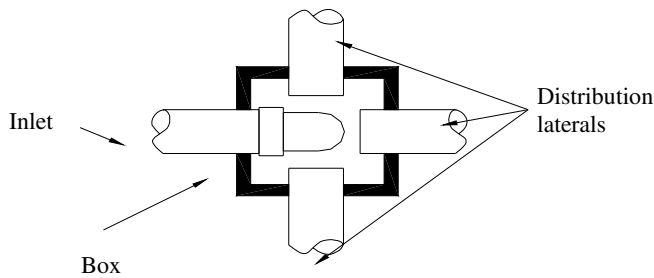

Cross section view

INSTALLATION

The distribution box must be installed level to ensure equal distribution to each line is obtained. The distribution box is to be installed on 12-18 inches of broken stone (check system specifications). By installing the box on broken stone, easy installation adjustments can be made to the box. The distribution lines that connect to the distribution box must all be connected at the same elevation leaving the box.

Level Distribution Box

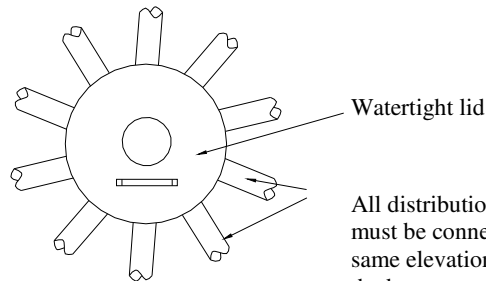

All distribution lines must be connected at the same elevation leaving the box

APPENDIX 14 – DISTRIBUTION BOX

Jointing of the distribution piping with a distribution box should be made with non-shrinking gasket material.

Common mistakes include:

- ❑ Roughly packing fill material on top of the box which will result in damaged or make the box uneven. Careful construction of systems will ensure the distribution boxes work as designed.
- ❑ Once a distribution box is installed, the owner must ensure that the ground above the box is not driven on by any vehicles or equipment.
- ❑ Shallow burial may result in distribution box freeze up. Be sure to check manufacturer specifications.

CARE AND MAINTENANCE

When installed correctly, the distribution box can be maintenance free. Proper installation is critical to ensure the box does not freeze during cold months. To achieve this, all effluent must evenly flow from the box into the all distribution lines. Ponding of effluent in an uneven box can result in freeze up and overload to a sewage system.

The distribution box is very subject to movement caused by frost heave. After use over one winter, it is normal to find the distribution box off level and distributing a large amount of effluent to the lower end and little or no effluent to weeping laterals connected to the higher end of the now sloping distribution box.

To minimize this problem, it is important to:

- ❑ keep the distribution box as small as possible
- ❑ keep the outlets as close together as possible
- ❑ prevent the momentum of the incoming effluent from washing directly onto an outlet.

APPENDIX 15 – SOIL TESTS**DEFINITION**

A test or tests used to determine the rate that soil will accept water. It includes but is not limited to a soil percolation test or a soil texture classification/method.

FUNCTION

The most important criteria in the design of an effluent treatment and disposal system is the soil. To design the system for a given amount of effluent, the ability of the soil to absorb and treat the effluent must be determined. A system that is undersized may operate for a short but it will soon become clogged with the organic material and suspended solids in the effluent. The soil will no longer be able to absorb the effluent and a failure of the system will occur.

A close examination of the soil and proper testing of the soil is required for the sound design of a system and to assure the long-term acceptance of effluent. There are two tests or methods used to determine the effluent acceptance rate of the soil. These are the Percolation Test and Soil Texture Classification.

DESIGN AND INSTALLATION

Percolation Test

The purpose of the percolation test is to obtain data that can be used to determine the soil infiltration area required to accept the expected volume of sewage per day.

Soil with a rate of 40 to 50 min per 25 mm (per in) indicates a clay loam, which is a fine texture and has small pore spaces. A percolation test resulting in a rate of 5 to 10 min per 25 mm (per in) indicates a coarse or porous soil texture such as loamy sand. The clay loam accepts and transmits water much slower than a soil such as loamy sand.

The rate at which a soil will accept water or effluent is dependent (to a great extent but not exclusively) upon the size of the pore spaces between the individual soil particles. Sand particles are large and leave large pore spaces between particles causing little restriction to the movement of air and water or effluent through the soil. Clay particles are extremely small particles and accordingly, leave extremely small pore spaces between the particles providing a greater restriction to the movement of air and water or effluent.

A percolation test is subject to many factors that may influence the results obtained and thus the relevance of the results obtained. Some of these factors include:

- ❑ improper soaking or failure to properly pre-soak the test hole,
- ❑ a large pore in the soil created by a dead plant root,
- ❑ animal burrows,
- ❑ cracks in dry clayey soil,
- ❑ changes in the soil texture and structure of the underlying soil layers (soil horizons),
- ❑ locating the test hole in areas of previous excavations,
- ❑ frozen soil, and
- ❑ location of test holes not representative of disposal site conditions.

APPENDIX 15 – SOIL TESTS

A percolation test gives an indication of the rate the soil will accept and move clean water. See Appendix 8 and Appendix 10 for more information.

Sizing a system with a Percolation Test

When using the results of a percolation test to size a system, the total area of weeping lateral trench bottom required should be determined from the following formulas:

$$\square \text{ Square Metres} = \frac{\text{LitresPerDay}}{\left\{ \left\{ \frac{3}{\sqrt{\text{PercolationRate}}} \right\} \times 27.36 \right\}}$$

Where

Square metres = Trench bottom area (not including walls)

Litres per day = Expected sewage volume in litres/day

Percolation rate = percolation rate in minutes/25mm, or

$$\square \text{ Square Feet} = \frac{\text{GallonsPerDay}}{\left\{ \left\{ \frac{3}{\sqrt{\text{PercolationRate}}} \right\} \times 0.56 \right\}}$$

Where

Square Feet = Trench bottom area (not including trench walls)

Gallons per Day = expected sewage volume in gallons/day

Percolation Rate = percolation rate in minutes/inch

Example: 4 bedroom house = 2040 Litres per day (See Appendix 1 for volume/day)
Percolation Rate = 36 min/25 mm

$$\square \text{ Square Metres} = \frac{2040L / \text{Day}}{\left\{ \left\{ \frac{3}{\sqrt{36}} \right\} \times 27.36 \right\}}$$

Square metres of disposal field trench required = 149.92 m²

APPENDIX 15 – SOIL TESTS

Soil Investigations

Site investigations may require soil investigations. Soil characteristics are to be evaluated and described in accordance with the following recognized methods:

- Canadian System of Soil Classification, 3rd Edition;
- Standard Practice for Subsurface Site Characterization of Test Pits for On-Site Septic Systems (ASTM D 5921);
- Other method acceptable to the Health Region.

Particle sizing is to be conducted in a qualified soils laboratory utilizing either the pipette or the hydrometer method. The percentages of sand, silts and clays particles and the soil texture classification are to be determined and reported.

Soil Texture Classification

Soil texture affects the movement of water in the soil.

Soil texture classification may be used in calculating the effluent loading rate in litres per square metre (gallons per square foot) for that soil texture classification. The soil texture is a classification determined by the relative amounts of sand, silt and clay in a soil (the mineral portions of the soil). How coarse (sandy) or fine (clay) the soil is, affects the ability of the soil to transmit air and water or effluent.

The mineral portion of the soil (excluding fragments with a mean diameter larger than 2 mm) is divided into three size fractions: Sand (S) with particle sizes between 2.00 and 0.05 mm, Silt (S) with particle sizes between 0.05 and 0.002 mm, and Clay (C) with particle sizes less than 0.002 mm.

Soil texture refers to the relative percentage of sand, silt, and clay in a soil, i.e., particle size distribution. The texture of a soil is expressed as a class name formed by combining the terms of sand, silt, clay and loam. For example, if the clay fraction dominates the properties of the soil, the soil class name would simply be “clay.” However, if this soil contains enough sand to appreciably modify the properties imparted by the clay, then the class name would be “sandy clay.” When the percentage of sand and clay are known, the class name can be determined from the textural triangle shown in Appendix 15. There are ways of accurately determining soil texture in the laboratory such as the pipet and hydrometer methods. Where the soil texture is to be used as the only sizing criteria the soil must be analyzed by a soils laboratory using recognized methods.

A less precise method, manual texturing, can be employed in the field to make estimates of soil texture and is based on the “feel” of a moist soil sample.

Hand Texturing of Soil

To hand texture, you may wish to try the steps below or those in the graphic illustration (Appendix 9).

- ❑ Place about a teaspoon of soil in the palm of your hand and moisten the soil by slowly adding water.
- ❑ Knead the soil and add water until it has the consistency of moist putty (not soup).
- ❑ To estimate the textural class, use the following guidelines:
- ❑ Pure clay will feel very slippery and very sticky
- ❑ Pure silt will feel smooth and slippery but not sticky
- ❑ Pure sand will feel very gritty.
- ❑ Press and rub the moistened soil between your thumb and forefinger to estimate the gritty and slippery feel, then pull the two fingers apart to estimate stickiness.

APPENDIX 15 – SOIL TESTS

This is an example procedure for hand texturing of a soil sample. Be advised that this is presented as an additional example of a qualitative field technique and that accuracy improves with experience (often many years are required). By obtaining a number of known soil texture samples you can practice with these to help you calibrate your fingers to do the manual texturing of soils.

Textural Properties of Dry and Wet Mineral Soils

Soil	Feeling and Appearance	
Class	Dry Soil	Moist Soil
Sand	Loose, single grains which feel gritty. Squeezed in the hand, the soil mass falls apart when the pressure is released.	Squeezed in the hand, it forms a cast which crumbles when touched. Does not form a ribbon between thumb and forefinger.
Sandy Loam	Aggregates easily crushed; very faint velvety feeling initially but with continued rubbing the gritty feeling of sand soon dominates.	Forms a cast which bears careful handling without breaking. Does not form a ribbon between thumb and forefinger.
Loam	Aggregates are crushed under moderate pressure; clods can be quite firm. When pulverized, loam has velvety feeling that become gritty with continued rubbing. Casts bear careful handling.	Cast can be handled quite freely without breaking. Very slight tendency to ribbon between thumb and forefinger. Rubbed surface is rough.
Silt Loam	Aggregates are firm but may be crushed under moderate pressure. Clods are firm to hard. Smooth, flour-like feel dominates when soil is pulverized.	Cast can be freely handled without breaking. Slight tendency to ribbon between thumb and forefinger. Rubbed surface has a broken or rippled appearance.
Clay Loam	Very firm aggregates and hard clods that strongly resist crushing by hand. When pulverized, the soil takes on a somewhat gritty feeling due to the harshness of the very small aggregates which persist.	Cast can bear much handling without breaking. Pinched between the thumb and forefinger, it forms a ribbon whose surface tends to feel slightly gritty when dampened and rubbed. Soil is plastic, sticky and puddles easily.
Clay	Aggregates are hard; clods are extremely hard and strongly resist crushing by hand. When pulverized, it has a grit-like texture due to the harshness of numerous very small aggregates which persist.	Casts can bear considerable handling without breaking. Forms a flexible ribbon between thumb and forefinger and retains its plasticity when elongated. Rubbed surface has a very smooth, satin feeling. Sticky when wet and easily puddled.

Please see Appendix 9 for more information.

APPENDIX 15 – SOIL TESTS**Sizing Using Soil Texture Loading Rates:**

When using the results of a soil texture classification to size a system, the disposal field weeping lateral trench bottom area should be sized as:

- Clay, not suitable without further testing,
- Silty Clay, not suitable without further testing,
- Silty Clay Loam, not suitable without further testing,
- Sandy Clay, not suitable without further testing,
- Clay Loam, 10.78 L/m² (0.22 gals/ft²),
- Silt, 12.25 L/m² (0.25 gals/ft²),
- Sandy Clay Loam 13.72 L/m² (0.28 gals/ft²),
- Silt Loam, 13.72 L/m² (0.28 gals/ft²),
- Loam, 17.15 L/m² (0.35 gals/ft²),
- Sandy Loam, 22.05 L/m² (0.45 gals/ft²),
- Loamy Sand, 30.87 L/m² (0.63 gals/ft²) and
- Sand, not suitable without further testing.

Intent: Soils classed as not suitable without further testing for a disposal field in this table may have an infiltration rate that will accommodate a disposal field. Further testing, such as a percolation test, may indicate the soil can accommodate a disposal field.

In very porous soils or soils that have a percolation rate of less than 5 min. per 25 mm (5 min. per inch), an effluent disposal system may be provided with a layer of soil 300 mm (1 foot) thick that has a percolation rate in excess of 5 min. per 25 mm (5 min. per inch). This liner provides a restrictive layer of soil that the effluent passes through at a slower rate. When the effluent reaches the excessively porous soil outside the liner, there is not sufficient flow rates to allow saturated flow conditions through the porous soil. This forces the effluent to flow through the porous soils in thin films, from soil particle to soil particle providing both exposure to oxygen and sufficient time to treat the effluent. While sufficient treatment of pathogens is expected using this method it does not remove nitrate from the effluent.

Soils determined to be "not suitable without further testing" as outlined above will require further analysis. Additional information is required in order to determine if a narrower and longer system is an option for adequate treatment of wastewater.

- A soil structure analysis/grade analysis should be conducted as outlined in this appendix or by a soils laboratory
- The "Effluent Soil Loading Rates and Linear Loading Rates" table utilizes soil texture, structure, soil grade, distance to a restrictive layer & slope of the site to determine the dimensions and loading rates for a system.

Table A.15 Effluent Soil Loading Rates and Linear Loading Rates													
Soil characteristics				Hydraulic Linear Loading Rate, Imp. gal/da/ft									
				Slope of land									
Soil characteristics		Infiltration loading rate: (Imp. gal/day/ft ²)		0-4%			5-9%			>10%			
		Effluent Quality (BOD)		Infiltration distance, in. ¹			Infiltration distance, in. ¹			Infiltration distance, in. ¹			
Texture	Structure		>30 mg/L	<30 mg/L	8-12	12-24	24-48	8-12	12-24	24-48	8-12	12-24	24-48
	Shape	Grade											
COS, S, LCOS, LS	--	OSG	0.30	0.30	4.0	5.0	6.0	5.0	6.0	7.0	6.0	7.0	8.0
FS,VFS,LFS, LVFS	--	OSG	0.40	0.50	3.5	4.5	5.5	4.0	5.0	6.0	5.0	6.0	7.0
CSL, SL	--	OM	0.20	0.60	3.0	3.5	4.0	3.6	4.1	4.6	5.0	6.0	7.0
		PL	1	0.20	0.50	3.0	3.5	4.0	3.6	4.1	4.6	4.0	5.0
	PR/BK /GR	1	0.40	0.60	3.5	4.5	5.5	4.0	5.0	6.0	5.0	6.0	7.0
		2,3	0.60	0.60	3.5	4.5	5.5	4.0	5.0	6.0	5.0	6.0	7.0
FSL, VFSL	--	OM	0.18	0.36	2.0	2.3	2.6	2.4	2.7	3.0	2.7	3.2	3.7
		PL	1	0.18	0.36	2.0	2.3	2.6	2.4	2.7	3.0	2.7	3.2
	PR/BK /GR	1	0.18	0.45	3.0	3.5	4.0	3.3	3.8	4.3	3.6	4.1	4.6
		2,3	0.32	0.63	3.3	3.8	4.3	3.6	4.1	4.6	3.9	4.4	4.9
L	--	OM	0.18	0.45	2.0	2.3	2.6	2.4	2.7	3.0	2.7	3.2	3.7
		PL	1	0.30	0.45	3.0	3.5	4.0	3.3	3.8	4.3	3.6	4.1
	PR/BK /GR	1	0.30	0.45	3.0	3.5	4.0	3.3	3.8	4.3	3.6	4.1	4.6
		2,3	0.45	0.63	3.3	3.8	4.3	3.6	4.1	4.6	3.9	4.4	4.9
SIL	--	OM	0.00	0.18	2.0	2.5	3.0	2.2	2.7	3.2	2.4	2.9	3.4
		PL	1	0.30	0.45	2.4	2.7	3.0	2.7	3.0	3.3	3.0	3.5
	PR/BK /GR	1	0.30	0.45	2.4	2.7	3.0	2.7	3.0	3.3	3.0	3.5	4.0
		2,3	0.45	0.63	2.7	3.0	3.3	3.0	3.5	4.0	3.3	3.8	4.3
SCL, CL, SICL, SI	--	OM	0.00	0.00	-	-	-	-	-	-	-	-	-
		PL	1,2,3	0.00	0.15	2.0	2.5	3.0	2.2	2.7	3.2	2.4	2.9
	PR/BK /GR	1	0.18	0.27	2.0	2.5	3.0	2.2	2.7	3.2	2.4	2.9	3.4
		2,3	0.27	0.45	2.4	2.9	3.4	2.7	3.0	3.3	3.0	3.5	4.0
SC, C, SIC	--	OM	0.00	0.00	--	--	--	--	--	--	--	--	--
		PL	1,2,3	0.00	0.00	--	--	--	--	--	--	--	--
	PR/BK /GR	1	0.00	0.00	--	--	--	--	--	--	--	--	--
		2,3	0.14	0.20	2.0	2.5	3.0	2.2	2.7	3.2	2.4	2.9	3.4
COS – Coarse Sand			LVFS – Loamy Very Fine Sand					SI – Silt					
S – Sand			COSL – Coarse Sandy Loam					SCL – Sandy Clay Loam					
LCOS – Loamy Coarse Sand			SL – Sandy Loam					CL – Clay Loam					
LS – Loamy Sand			FSL – Fine Sandy Loam					SICL – Silty Clay Loam					
FS – Fine Sand			VFSL – Very Fine Sandy Loam					SC – Sandy Clay					
LFS – Loamy Fine Sand			L – Loam					C – Clay					
VFS – Very Fine Sand			SIL – Silt Loam					SIC – Silty Clay					
PL – Platy		PR – Prismatic		BK – Blocky		GR – Granular		M – Massive			SG – Single Grain		
0 – Structureless		1 – Weak		2 – Moderate		3 – Strong							

¹ Note: Infiltration distance is the depth below the undisturbed native soil infiltration surface effluent is applied to.

In Table A.15, infiltration rates are in gal/d/ft² for wastewater of >30 mg/L or wastewater of <30 mg/L and hydraulic linear loading rates in gal/d/ft for soil characteristics of texture and structure and site conditions of slope and infiltration depth to limiting soil layers. Values assume daily wastewater volume estimates used in the design are based on the values set out in the guideline. If horizon consistence is stronger than firm or any cemented class or the clay mineralogy is smectitic, the horizon is limiting regardless of other soil characteristics {adapted from 2000 E. Jerry Tyler and Alberta Private Sewage Systems Standard of Practice Proposed Revisions March 1st 2007.}

Note that if the <30 mg/L BOD effluent quality is used for design no additional field reduction sizes (eg. pressure reduction) are allowed.

It is highly recommended that soils classified as COS, S, LCOS, LS, FS, VFS, LFS, LVFS, CSL, SL utilize pressure distribution. Timed dosing should also be considered in these situations.

Sizing Example Using Table A.15

The following example is based on constructing a sand mound for a 3 bedroom house with Silty Clay Loam soil, blocky structure grade 2:

Using the Effluent Soil Loading Rates and Linear Loading Rates table in Appendix 15 A Silty Clay Loam soil (SICL) with blocky structure, grade 2 would be given an infiltrative loading rate (BOD > 30mg/l) of 0.4 gal/day/sq.ft. Given a 0% slope and no restrictive layers (24-48 Infiltration distance, inch).

Sand Layer

$$\text{Area: } \frac{337.5 \text{ gal/day}}{1 \text{ gal/day/sq.ft.}} = 337.5 \text{ sq.ft.}$$

However, minimum size is 400 sq. ft.

$$\text{Width: } \frac{3.0 \text{ gpd/ft}}{1.0 \text{ gal/day/sq.ft.}} = 3.0 \text{ ft}$$

$$\text{Length: } \frac{400 \text{ sq ft}}{3.0 \text{ ft}} = 133 \text{ ft length}$$

Note: 3.0 gpd/ft is the linear loading rate from the table. Because sand is loaded at 1.0 gal/day/sq. ft., this loading rate equals the width of the sand layer.

Native Soil

$$\text{Area: } \frac{337.5 \text{ gal/day}}{0.4 \text{ gal/day/sq.ft.}} = 843.75 \text{ sq.ft.}$$

$$843.75 \text{ sq.ft.} \times 70\% = 591 \text{ sq.ft.}$$

30% reduction allowed for Type II mounds

$$\text{Width: } \frac{591 \text{ sq. ft.}}{133 \text{ ft}} = 4.4 \text{ ft width}$$

$$\text{Length: } 133 \text{ ft (from length of sand mound)}$$

Note: Either the geometry of the berm or the required native soil width may be the limiting condition. See Appendix 7 for Type II mound calculations.

APPENDIX 15 – SOIL TESTS

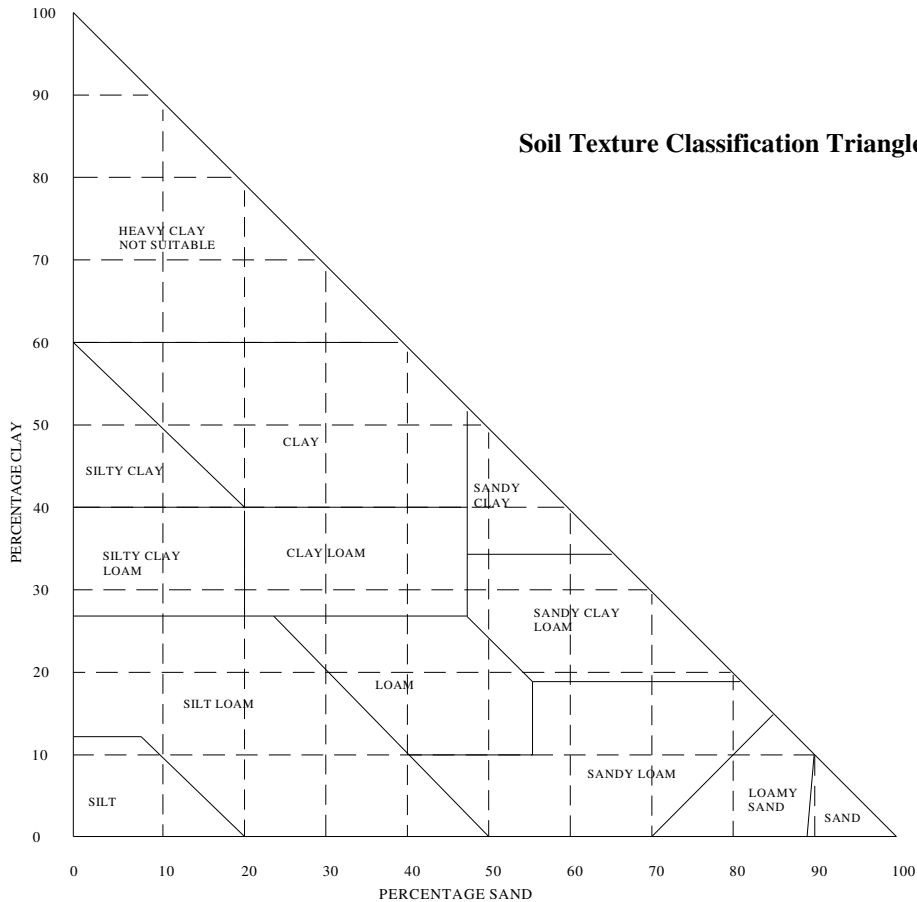

Calculating the size of the system using soil test data

The following examples are based on a 3-bedroom house in clay loam, silt, and loamy sand soils.

Clay Loam Soils:

3 bedroom house effluent volume: 1530 L (337.5 gals)
 Soil loading rate: 10.78 L/m² (0.22 gals/ft²)

$$\begin{aligned}
 \text{Area of trench required} \quad m \text{ (ft.)} &= \frac{\text{effluent volume L(gals)}}{\text{L/m}^2 \text{ (gals/ft}^2\text{)}} \\
 &= \frac{1530 \text{ (337.5 gals)}}{10.78 \text{ L/m}^2 \text{ (0.22 gals/ft}^2\text{)}} \\
 &= 141.9 \text{ m}^2 \text{ (1534 ft}^2\text{)}
 \end{aligned}$$

APPENDIX 15 – SOIL TESTS**Silt Soils:**

3 bedroom house effluent volume: 1530 L (337.5 gals)
Soil loading rate: 12.25 L/m² (0.25 gals/ ft²)

$$\begin{aligned} \text{Area of trench required} \quad m \text{ (ft.)} &= \frac{\text{effluent volume L(gals)}}{\text{L/m}^2 \text{ (gals/ft}^2\text{)}} \\ &= \frac{1530 \text{ L (337.5 gals)}}{12.25 \text{ L (0.25 gals/ft}^2\text{)}} \\ &= 124.8 \text{ m}^2 \text{ (1350 ft}^2\text{) trench} \end{aligned}$$

Loamy Sand Soils:

3 bedroom house effluent volume: 1530 L (337.5 gals)
Soil loading rate: 30.87 L/m² (0.63 gals/ft²)

$$\begin{aligned} \text{Area of trench required} \quad m \text{ (ft.)} &= \frac{\text{effluent volume L(gals)}}{\text{L/m}^2 \text{ (gals/ft}^2\text{)}} \\ &= \frac{1530 \text{ L (337.5 gals)}}{30.87 \text{ L/m}^2 \text{ (.63 gals/ft}^2\text{)}} \\ &= 49.56 \text{ m}^2 \text{ (535.7 ft}^2\text{)} \end{aligned}$$

APPENDIX 16 – OPERATIONAL TIPS FOR SEPTIC SYSTEMS

WATER USAGE

Starting the sewage treatment process for a newly installed septic tank would be as if it had been in operation for awhile. Normally, as the tank fills, the natural processes begin. Some have suggested adding 1000 to 1400 L (200 to 300 gals) of water before use. The use of some hot water is recommended, particularly in the winter.

Less water going into the septic tank means less turbulence in the tank, better settling of solids, and cleaner tank effluent. The results are less frequent tank pumping, a longer lasting septic system, and better sewage treatment.

- ❑ Repair leaky fixtures. Check your toilet by dropping food dye in the toilet tank and see if it shows up in the bowl without flushing.
- ❑ Consider low flow toilets, showerheads, and water faucets. Even properly functioning toilets rank as the number one water user, standard toilets use 3.5 to 5 gallons per flush. Low flow appliances and devices can reduce water usage by 25-30%.
- ❑ Use dishwasher only when full.
- ❑ Avoid house over-occupancy.
- ❑ Reroute drainage such as run-off from the roof, hot tubs, and yard drainage away from septic system area to avoid over-saturation.
- ❑ Plug bathtub before starting water.
- ❑ Plug sink while washing or shaving.
- ❑ Distribute laundry chores and other heavy water uses so that the system has time to work between doses.

A too-often-for-too-long saturated condition in an absorption field eventually results in clogged septic system branches that may have to be replaced. **It is critical to maintain unsaturated conditions within and beneath the septic system.**

DISPOSAL PRACTICES

Just as important as how much water goes into your system is *what* goes into your system. Again, remember that all phases of onsite wastewater treatment rely on a mixture of biological organisms to clean and purify the wastewater – a community of bugs is working for you, so do not dispose of products that will kill off these hard working bugs.

- ❑ Don't use your toilet as a trash can. Never put any bulky wastes such as disposable diapers, sanitary napkins, paper towels, coffee grounds, hair, cooking oil, or anything plastic – cigarette filters, tampon applicators, or condoms – into a septic system. Any of these may plug up the inlet or the outlet and are very slow to decompose, if they breakdown at all.

APPENDIX 16 – OPERATIONAL TIPS FOR SEPTIC SYSTEMS

- ❑ Grease from cooking, if dumped down the drain, will solidify on route to the septic tank and thus could clog the system.
- ❑ Beware of Chemicals! They kill septic system bacteria.
 - Never dispose of these chemicals in a septic system: gasoline, motor oil, antifreeze, paints, varnishes, paint thinners, medicines herbicides, photographic chemicals.
 - Drain cleaners are caustic products that can damage plumbing. Drain cleaners are chemicals that generate heat when exposed to air. Try pouring boiling water down the drain to dissolve clogs.
 - Toilet bowl cleaners are either caustic or acids. Try mild detergent or baking soda.
 - Disinfectants won't help much in the toilet and certainly not in the tank.

Garbage Disposal Waste

If your home has a garbage disposal unit, you will need to clean the septic tank annually or more often.

Homes with a garbage disposal should increase their septic tank capacity by at least 50 percent greater.

It is better to compost, or throw out garbage than to add it to the sewage treatment system. Materials like lettuce, potato peelings, etc. do not break down completely, thus adding volume to the accumulated solids in the tank.

Detergents

Detergents can cause problems with septic systems. Inexpensive washing products are often the most detrimental to sewage systems, containing fillers or carriers, which add to the accumulated solid in a septic tank. The liquid laundry detergents are less likely to have the fillers or carriers.

Non-Decomposable Material

Do not deposit coffee grounds, cooking fats, wet strength paper towels, disposable diapers, facial tissues, cigarette butts and similar non-decomposable material into the sewage system. None of these materials will decompose, and they will cause the rapid accumulation of solids in the septic tank.

Cleaning

Cleaning frequency of a septic tank depends upon the tank capacity, the number of people using the system, and the use of appliances such as a garbage disposal.

APPENDIX 16 – OPERATIONAL TIPS FOR SEPTIC SYSTEMS

The tank should be cleaned when half of the initial liquid capacity is occupied by solids. Some tanks may need cleaning at two years or sooner. Every two years is a reasonable schedule for an average household. The following table suggests how often you need to pump out your septic tank on average, given the size of the tank and the number of persons living in the household. These figures were calculated assuming there was not garbage disposal unit hooked up to the system.

Tank Size	Household Size (number of people)					
	1	2	3	4	5	6
2300 L	7.5	3.3	1.8	1.3	1.0	0.7
2700 L	9.1	4.2	2.6	1.8	1.3	1.0
3800 L	11.0	5.2	3.3	2.3	1.7	1.3

Estimated Septic tank Pumping Frequency in Years.

Remember, commercial septic tank additives will not eliminate the need for periodic clean out.

It is not necessary to leave solids in the septic tank to “start” it again. The tank should always be completely emptied. However, scrubbing and flushing the tank until it is visibly clean may delay the re-establishment of its normal operation.

Additives

While many products on the market claim to help septic systems work better, the truth is there is no magic potion to cure an ailing system. Some proprietary products that claim to “clean” septic tanks contain chemicals that may cause the scum and sludge to be discharged from the tank to the septic system. In essence, they change a simple maintenance item (regular pumping of tank) into a major system failure (clogged media/branch).

There are two types of septic system additives: biological (bacteria, enzymes and yeast) and chemical. At best, an additive is benign; it provides no benefit and it costs you some money. At worst, it can damage concrete and clog the soil; and products that contain solvents can contaminate the groundwater. The general consensus among septic system experts is that septic system additives are unnecessary, possibly harmful, and should not be used. The naturally occurring bacterial population in your tank does not need to be augmented for proper operation of your system. The best results come from a balanced and well-maintained system that is not overloaded or abused.

As a general rule, only three things should go into the septic tank: human wastes, toilet paper and waste from bathing fixtures and kitchen sinks.

APPENDIX 16 – OPERATIONAL TIPS FOR SEPTIC SYSTEMS

Physical Care

Unless specifically designed for vehicle traffic, no portion of your septic system should be driven on. If your tank is in an area subject to traffic, install a barricade to prevent damage to the tank and/or risers.

In order to protect from freezing, the site should be kept covered during the winter months with at least 0.5 m of snow or straw bales when snow cover is inadequate. Grass cover should be established over the entire site. Shrubs or trees should not be planted on the top of site areas to prevent root interference/clogging.

Traffic is generally prohibited from septic system sites to prevent compaction of the soil and to minimize the breaking and collapsing of buried pipes. Soil compaction can severely limit the transfer of oxygen and therefore hasten the development of anaerobic conditions. Remember we want aerobic conditions in the septic system media.

Similarly, septic system sites should not be paved in any manner.

Tenants

If you rent your property, please make your tenants aware that your property is served by a septic system. You have a considerable investment in your septic system, don't take a chance on needing an expensive absorption field replacement.

Another reason to properly operate and maintain a septic system is the potential for health problems from polluted water. A failing system could contaminate groundwater, and consequently nearby wells. Such water pollution also could reach nearby streams; and thus spread throughout a community. Inadequately treated sewage contains nutrient levels (nitrogen from urine and feces; phosphorus from soaps and detergents) which could be too high for the natural environment to handle. This type of sewage also contains pathogens, viruses, heavy metals, and chemicals from products improperly disposed of in septic systems.

COMMON SEPTIC SYSTEM PROBLEMS

Plantings

Roots in and around your septic system can cause serious problems. Roots can clog pipes, break apart tanks, infiltrate the gravel/sand in your septic system and render a system completely inoperable. If roots are observed infiltrating your tank during an inspection, you must have them removed as soon as possible. If your septic system is slow to accept the applied hydraulic loading during an inspection, you may be required to excavate certain areas of your system to investigate possible root intrusion. If you act promptly and remove the roots, there is a high probability you will be able to salvage your system and keep it operational.

APPENDIX 16 – OPERATIONAL TIPS FOR SEPTIC SYSTEMS

Odors

Odors emanating from a septic system can be indicative of a saturated field/media. During normal use of an unsaturated system, the gases in the septic tank will pass with the wastewater into the soil and be absorbed. If a field is saturated, the gases tend to migrate up the plumbing vents and your neighbors will notice a "septic odor."

Surfacing Effluent

Effluent ponding in an septic system site area, breaking out down hill from a system or flooding out the top of the tank is a serious concern and should be addressed immediately. **Please limit exposure to suspected untreated effluent. Keep children and/or pets away from the area and contact the local Public Health Inspector as soon as possible.**

Power Outage

The lights have gone out, you are scrambling around for candles and the last thing on your mind is your septic system. If you have a gravity system, your sewage disposal needs will be met for the duration of the power outage. If your system incorporates a pump, the pump will not function until the return of power. To prevent sewage from backing up in your plumbing, your household must minimize all wastewater generation. Typically, a system has 200 to 300 gallons of emergency storage just for this occurrence and since your electrical appliances (washing machine, dishwasher and electrical hot water heater) won't be working, the household will naturally be using less water. When power returns, you may hear an alarm sound because the alarm has been triggered by the high water conditions in the tank. After the pump lowers the effluent level, the alarm buzzer should stop.

During a prolonged period of low voltage, septic system pumps and panels can be damaged. This happens when the pump continues to try and come on. If this happens, you may want to turn the pump off until complete power is restored. Again, it is essential to reduce water usage and get the pump back in operation as soon as possible.

Safety

Safety practices should be followed when having to enter a septic tank that has been in use. Do not smoke or use open flames, lights, or heaters. Never allow anyone to go down into the septic tank unless a continuous supply of fresh air is pumped into the tank. If ventilation is not possible, then an air supplied mask or self-contained breathing apparatus should be worn. Have two or more persons conduct any work.

When entering the tank, do so with a harness type safety belt and an attached safety rope lowered into the tank by the other workmen located on the ground surface. The workmen on the ground surface must have enough strength to pull the person, in the tank, out in case of asphyxiation. If the rescuer must enter the tank, they must use an air supplied mask or self-contained breathing apparatus. Any protective equipment to be used must be put on before entering the tank. Remember, fatalities have occurred during septic tank maintenance and repair.

APPENDIX 17 - PRESSURE DISTRIBUTION: ORIFICE, PIPE AND PUMP SIZING

This worksheet is used to: size the orifices in distribution lateral pipes, size effluent delivery piping, and to calculate the required capacity and pressure head capability of the effluent pump. It can be used for: calculating delivery of effluent to laterals in disposal fields, mounds, and sand filters.

Use only one unit of measurement throughout (Imperial measures provided for example purposes.)

Step 1) Select the pressure to be maintained at the orifices:

Minimum pressure at the orifice:
- mound .60 m (2ft).

Design pressure
at orifice m (ft)

m (ft)
P1

For most systems use 1.5 m (5 ft)

NOTE: This worksheet will not provide an adequate design if laterals are at different elevations. Differing elevations will result in a different pressure head and volume of discharge at the orifices in each lateral. Additional considerations must be made for laterals at differing elevations.

Step 2) Select the size of orifice in the laterals:

Minimum size – .32 mm (1/8 in)
(larger sizes are less likely to plug)

Orifice diameter selected
mm (inches)

mm (in)
P2

Step 3) Select the spacing of orifices and determine the number of orifices to be installed in distribution laterals:

Length of distribution lateral

From system design drawings

m (ft)

÷

Spacing of orifices

m (ft)

=

Calculated # of orifices

P3a

Select a spacing of orifices to attain even distribution over the treatment area.

Maximum spacings are determined:

- for a mound – 1.5 m (5 ft)

(close spacing provides effective, even distribution)

Calculated # of orifices
(Rounded up to nearest 1)

From P3a this worksheet.

+

1 (for orifice at end)

=

Total Orifices in Each Lateral

P3b

1 extra orifice should be included in the calculations because of the orifice at the start of the lateral.

Total orifices in each lateral

From P3b this worksheet.

X

Number of laterals

If laterals are of differing lengths, calculate each separately and add the number of orifices together.

=

Total number of orifices all laterals

P3

APPENDIX 17 - PRESSURE DISTRIBUTION: ORIFICE, PIPE AND PUMP SIZING

Step 4) Determine the minimum pipe size of the distribution laterals:

Enter the system design information into the 3 boxes below. If distribution laterals are of differing lengths, each lateral must be considered separately.

Orifice diameter

 mm (in)

From **P2** this worksheet.

Length of distribution lateral

 m (ft)

From system design drawings.

Total orifices each lateral

From **P3b** this worksheet.

Use Appendix 4 with the information above to determine the minimum size of the distribution lateral pipe.

Size of distribution lateral

From Appendix 4

 mm (in)-NPS

P4

Step 5) Determine the total flow from all orifices:

Total number of orifices

From **P3** this worksheet.

X

Gal/min. for each orifice

 L/min (Imp. gal/min)

From Appendix 5.

Total gallons per minute

 L/min (Imp. gal/min)

(Required from pump)

P5

Step 6) Select the type and size of effluent delivery pipe:

Use Appendix 6 to aid in decision.
A larger pipe will reduce pressure loss.

Pipe type and size selected

 mm (in)-NPS

P6

A minimum flow rate as follows will help scour the pipe:
49 Lpm for 40 mm (13 gpm for 1-1/2"), 64 Lpm for 50 mm (17 gpm for 2"), 140 Lpm for 75 mm (37 gpm for 3")

Step 7) Calculate the equivalent length of pipe for pressure loss due to fittings:

Number of fittings

X

Equivalent length m (ft)

 m (ft)

(For each fitting)
Refer to Appendix 13.

Equivalent length of all fittings

 m (ft)

(For pressure loss.)

P7

(In the line from the pump to the farthest end of the header for the distribution laterals.)

APPENDIX 17 - PRESSURE DISTRIBUTION: ORIFICE, PIPE AND PUMP SIZING

Step 8) Calculate the equivalent length of pipe from pump to the farthest end of header of distribution laterals for pressure loss:

Length of piping	Equivalent length of fittings		Total equivalent length	
<input style="width: 100%;" type="text" value="m (ft)"/>	<input style="width: 100%;" type="text" value="m (ft)"/>	+	<input style="width: 100%;" type="text" value="m (ft)"/>	P8
<i>(From pump to far end of header for the distribution laterals.)</i>	<i>For pressure loss. From P7.</i>	=	<i>(For pressure loss Calculation)</i>	

Step 9) Calculate the pressure head loss in delivery pipe including fittings:

Total equivalent length	Friction loss		Delivery piping pressure head loss	
<input style="width: 100%;" type="text" value="m (ft) ÷ 30 m (100 ft)"/>	<input style="width: 100%;" type="text" value="m (ft)"/>	X	<input style="width: 100%;" type="text" value="m (ft)"/>	P9
<i>From P8 this worksheet. Don't forget to divide the length by 30 m (100 ft) to match the factors in the Tables.</i>	<i>(Per 100 ft of pipe)</i>		<i>(In delivery piping).</i>	
	<i>Use Appendix 6 using volume from P5 this worksheet.</i>			

Step 10) Calculate the total pressure head required at pump:

Delivery piping pressure loss	<input style="width: 100%;" type="text" value="m (ft)"/>	<i>FROM P9 THIS WORKSHEET.</i>
+		
Lift distance of effluent from low effluent level in tank to orifices	<input style="width: 100%;" type="text" value="m (ft)"/>	<i>Measure from lowest effluent level in tank to elevation of orifices.</i>
+		
Design pressure at orifices	<input style="width: 100%;" type="text" value="m (ft)"/>	<i>From P1 this worksheet.</i>
+		
Add .30 m (1 ft) to allow for pressure loss along the distribution lateral	<input style="width: 100%;" type="text" value="1 m (ft)"/>	
Total pressure head required at pump	<input style="width: 100%;" type="text" value="m (ft)"/>	P10

APPENDIX 17 - PRESSURE DISTRIBUTION: ORIFICE, PIPE AND PUMP SIZING

Step 11) Detail the Pump Specifications Required:

Required Flow Rate

From **P5** this worksheet

@

Required Pressure Head

From **P10** this worksheet.

Step 12) Repeat the calculations if it necessary to change the pump spec's:

If the flow rate through the orifices is too high: reduce the orifice diameter in Step 2, increase the orifice spacing in Step 3, or include a distributing valve to sequentially dose small portions of the system.

If the pressure head required is too high: select a lower design pressure in Step 1, reduce the flow rate as above, or increase the effluent delivery pipe size in Step 6.

Step 13) Select a make and model of pump and screen assembly:

Make or Manufacturer

Model

HP/Watts

Voltage & 1 Phase or 3 Phase

Amps.

Weight

Pump Flow Rate

Pump Pressure Head

@

Screen Description

*Don't forget that the effluent to a pressure distribution system should be screened.
Most pumps are rated in US gallons per minute. Be sure to select the pump in Imperial gallons per minute.
Conversion: US gallons X 0.83 = Imperial gallons or Imperial gallons X 1.2 = US gallons.*

Step 14) Confirm the design complies with the Guide.

Please work safely and follow safe practices near trenches and open excavations.

APPENDIX 18 – MAPS



Agriculture and Agri-Food Canada / Agriculture et Agroalimentaire Canada

Mean Annual Precipitation (mm) In Saskatchewan For The Standard 30 - Year Period 1971-2000

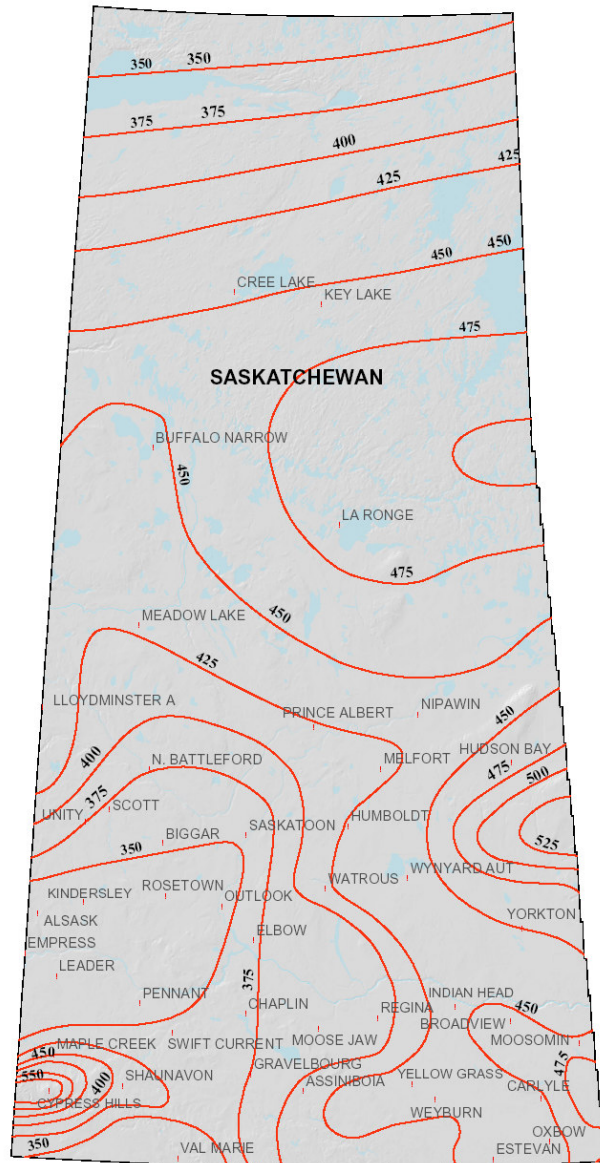

Projection: UTM
 Datum: NAD83
 Data Source: Isopleths were developed by the PFRA Hydrology Unit using Environment Canada data.

The Department of Agriculture and Agri-Food Canada (AAFC) employs reasonable efforts to ensure the currency and accuracy of geographic information presented through its maps and or Internet mapping applications.

All geographic information has limitations due to the scale, resolution, date and interpretation of the original source materials.

The Minister and AAFC make no assurance or warranty of any kind, either expressed or implied, as to the content of the geographic information on its maps and or Internet mapping applications.

AAFC does not assume nor accept any liability arising from any use of the information presented.



APPENDIX 18 – MAPS

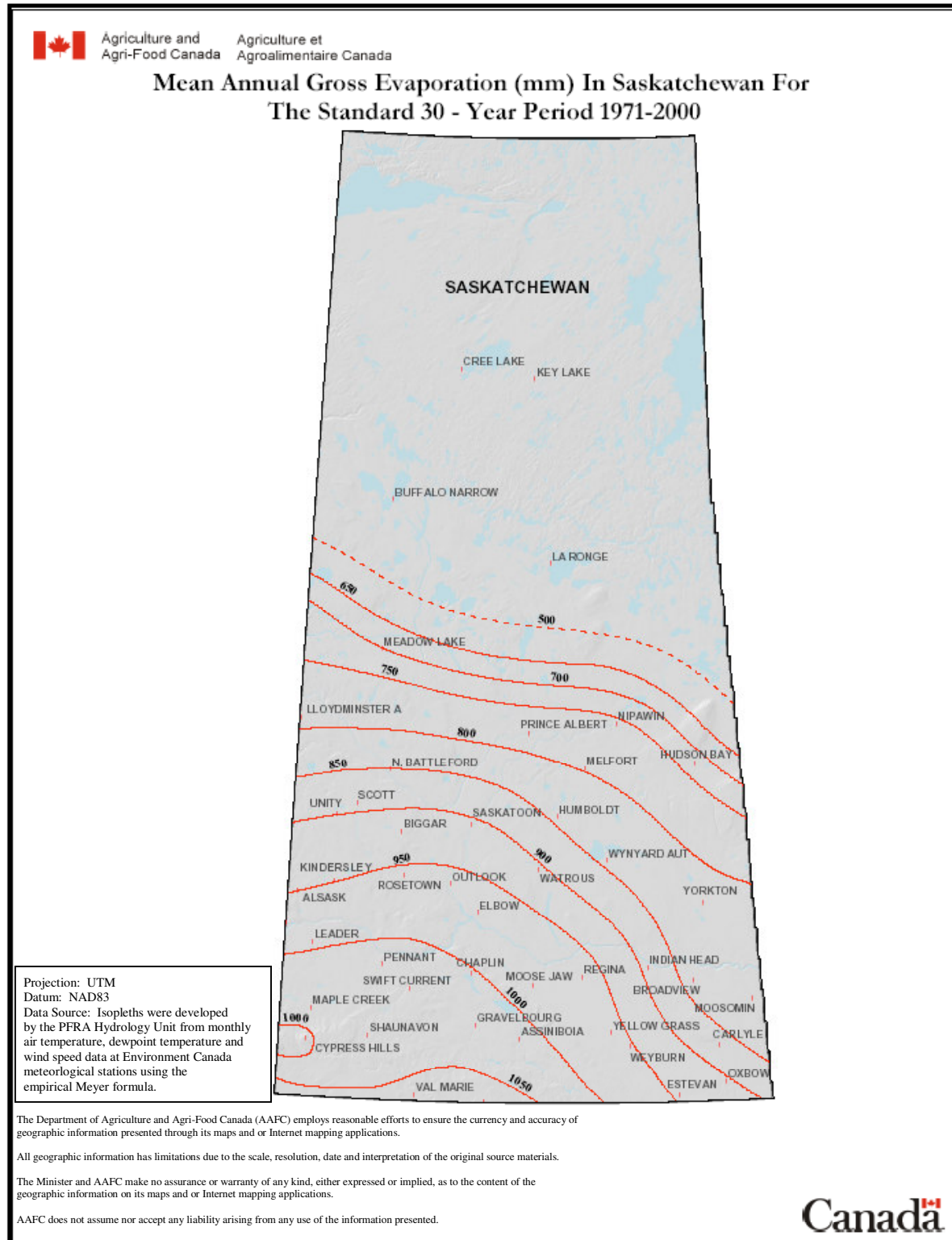

**APPENDIX 19 - EXAMPLE OF CALCULATION METHOD FOR DETERMINING
LAGOON DIMENSIONS**

(Refer to Section 11, Page X1-7)

Note: The following is an example for an installation in the Saskatoon area. Annual evaporation and precipitation rates differ for other areas of the province. Refer to Appendix 18 for mean annual precipitation and evaporation rates throughout the province.

EXAMPLE:

A three bedroom house that will produce an estimated 1,380 L per day of sewage in the Saskatoon area.

The estimated 1,530 L per day is equivalent to 558,450 L/year.

In Saskatoon:

- The estimated average annual evaporation is 913 mm.
- The estimated average annual precipitation is 360 mm.

$$\begin{aligned} \text{Step 1} \quad \text{Revap} &= 913 \text{ mm} - 360 \text{ mm} \\ &= 553 \text{ mm} \end{aligned}$$

$$\begin{aligned} \text{Step 2} \quad \text{Vevap} &= \frac{553 \text{ mm} \times 1,000,000 \text{ mm per square metre}}{1,000,000 \text{ cubic mm per litre}} \\ &= 553 \text{ L/m}^2 \end{aligned}$$

$$\begin{aligned} \text{Step 3} \quad \text{Area of the Lagoon} &= \frac{558,450 \text{ L} \times 1.25}{553 \text{ L/m}^2} \\ &= 1262 \text{ m}^2 \end{aligned}$$

Lagoon surface area needed would be: 35.5 m x 35.5 m

This would be the water surface size "B" at its operating depth.

$$\begin{aligned} \text{Step 4} \quad \text{Size at center line of berm "C" length.} \\ &= B + (\text{H:Vslope} \times \text{Freeboard} \times 2) + (2 \times \frac{1}{2} (\text{berm width})) \\ &= 35.5 \text{ m} + (3 \times .5 \text{ m} \times 2) + (2 \times \frac{1}{2} (2 \text{ m})) \\ &= 40.5 \text{ m} \end{aligned}$$

$$\begin{aligned} \text{Step 5} \quad \text{Select an operating depth (eg. 1.2 m) [A minimum operating depth of at least .6 m above} \\ \text{the inlet is necessary to prevent frost damage.]} \\ &= 1.2 \text{ m} \end{aligned}$$

$$\begin{aligned} \text{Step 6} \quad \text{Size at base "A" length} \\ &= B - (\text{H:Vslope} \times \text{Depth} \times 2) \\ &= 35.5 \text{ m} - (3 \times 1.2 \text{ m} \times 2) \\ &= 28.3 \text{ m} \end{aligned}$$

APPENDIX 20 – MINIMUM PARCEL/LOT SIZES AND SET BACK REQUIREMENTS

The following tables are for general information only, please refer to *Section 4 – Private Sewage Works In Sensitive Areas*, when considering any system. In addition, *The Shoreland Pollution Control Regulations, 1976*, and local municipal bylaws may further restrict the type of system permitted. Please consult your local Public Health Inspector for more information.

Minimum Parcel/Lot Sizes

TYPE OF SEWAGE DISPOSAL SYSTEM								
PARCEL/LOT SIZE	Holding Tank	Chamber	Absorption Field	Mound I	Mound II	Jet	Lagoon	Package Treatment Plant
10 acres or >	yes	yes	yes	yes	yes	yes	yes	yes
< 10 acres >465m ² (5000ft ²)	yes	yes	yes	yes	yes	no	no	yes
≤465m ² (5000ft ²)	yes	*	*	*	*	no	no	consult PHI

* consult your local Public Health Inspector

Set Back Requirements

TYPE OF SEWAGE DISPOSAL SYSTEM									
Set Back Requirements	Holding Tank	Septic Tank	Chamber	Absorption Field	Mound I	Mound II	Jet	Lagoon	Package Treatment Plant
<i>Basement/Building</i>	1m (3ft)	1m (3ft)	9m (30ft)	9m (30ft)	9m (30ft)	9m (30ft)	60m (200ft)	60m (200ft)	1m (3ft)
<i>Cistern</i>	3m (10ft)	3m (10ft)	----	----	----	----	----	----	----
<i>City, Town, Village</i>	----	----	----	----	----	----	1km (0.6 mile)	----	----
<i>Cut/ Embankment</i>	3m (10ft)	3m (10ft)	3m (10ft)	3m (10ft)	3m (10ft)	3m (10ft)	30m (100ft)	30m (100ft)	3m (10ft)
<i>Ground Water Table</i>	0m (0ft)	0m (0ft)	1.5 m (5ft)	1.5 m (5ft)	1.5 m (5ft)	1.5 m (5ft)	1.5 m (5ft)	1.5 m (5ft)	1.5 m (5ft)
<i>Large Tree</i>	3m (10ft)	3m (10ft)	----	----	----	----	----	----	----
<i>Property Boundary</i>	3m (10ft)	3m (10ft)	3m (10ft)	3m (10ft)	3m (10ft)	3m (10ft)	60m (200ft)	30m (100ft)	3m (10ft)
<i>Rec. Area</i>	----	----	60m (200ft)	60m (200ft)	60m (200ft)	60m (200ft)	60m (200ft)	60m (200ft)	----
<i>Roadway</i>	----	----	----	----	----	----	----	90m (300ft)	----
<i>Walk/ Driveway</i>	1.5 m (5ft)	1.5 m (5ft)	1.5 m (5ft)	1.5 m (5ft)	1.5 m (5ft)	1.5 m (5ft)	30m (100ft)	----	1.5 m (5ft)
<i>Water Course</i>	9 m (30ft)	9 m (30ft)	15m (50ft)	15m (50ft)	15m (50ft)	15m (50ft)	45m (150ft)	90m (300ft)	9m (30ft)
<i>Water Source</i>	9 m (30ft)	9 m (30ft)	15m (50ft)	15m (50ft)	15m (50ft)	15m (50ft)	45m (150ft)	90m (300ft)	9m (30ft)

Unless otherwise approved by a Public Health Inspector, (through consultation with Saskatchewan Environment officials), the set back distance from a well that is used as a water source for a municipal waterworks - should be at least 75 m (250 ft) in the case of a small municipality (less than 1,000 population) and at least 225 m (750 ft) in the case of a large municipality (1,000 or more population).

APPENDIX 21 – DOSING

Dosing

Dosed flow distribution systems are a significant improvement over gravity flow distribution networks. Dosing achieves better distribution of the wastewater effluent over the infiltrative surface than gravity flow systems and provides intervals between doses when no wastewater is applied. As a result, dosed-flow systems reduce the rate of soil clogging, more effectively maintain unsaturated conditions in the subsoil (to effect good treatment through extended residence times and increased re-aeration potential). Dosing can be used in almost any application and should be the method of choice. Unfortunately, dosing usually adds a mechanical device (ie. pump). However, in infiltration systems designed not to allow ponding, the improved performance should outweigh these concerns.

Dosing can be accomplished by one of two devices; a pump or a siphon. A siphon accomplishes on demand dosing of gravity or pressure systems where the elevation between the siphon invert and the orifices are sufficient for the siphon to operate. A pump can be used to perform on demand dosing or timed dosing. Timed dosing utilizing a pump provides the most effective treatment within the soil system.

Dose Volumes

Dosing of a drain field provides intermittent aeration to the infiltrative surfaces. This allows aerobic breakdown of the sewage effluent between doses. The resting phase should be sufficiently long enough to allow the system to drain. This allows the infiltrative surface to be exposed to the air, which encourages degradation of the sewage effluent by aerobic bacteria.

A final treatment area utilizing gravity distribution over the weeping lateral trench should receive a dose volume that encourages spreading over the entire infiltrative surface. Dose volumes should be within the range of 3.4 and 12 liters per square meter (0.07 to 0.25 Imperial gallons per square foot) of infiltrative soil surface.

Where the design is that of a Type II mound or pressure distribution chamber system the dose volumes should be delivered over the entire infiltration area as individual doses of effluent that do not exceed 20% of the average daily effluent volume.

Dose Volumes using Soil Type

In sands and gravels rapid infiltration of sewage effluent can potentially lead to contamination of the ground water if the ground water is close to the surface. Therefore, in these soils the drain field should be dosed with small volumes of wastewater so that a saturated soil condition with possible inadequate treatment does not occur.

In finer textured soil conditions such as silts or clays, disposal rather than treatment is the concern. In this case large less frequent doses are more appropriate. This situation provides longer aeration between doses.

The recommended dose volume is calculated by dividing the average daily flow by the dosing frequency.

The preferred dosing frequencies are indicated in the following table.

Soil Texture	Doses per Day
Medium and Fine Sand	4
Silty Sands and Sandy Silts	1 to 2
Silts and Clays	1

To allow for adequate pressurization of the system so effluent can be evenly distributed to the drain field, a general rule is that the volume of the effluent dosed to the drain field should be greater than or equal to 5 times the internal volume of the portion of the pipe network that drains between doses. It is not always possible to obtain a septic tank with the ideal size of effluent chamber or volume of dosing. It is however possible to adjust the location of the pump controls to set the pump to turn off at specific levels to discharge a measured amount of effluent as required.

APPENDIX 22 – TEST PITS**Test Pits**

Test pits (observation holes) are excavated to a minimum depth of 2.8 m or refusal (where you cannot dig further), whichever is shallower.

- The appropriate number of tests will depend on the size of the drainfield area and the variability of soil conditions. The contractor/installer/consultant/designer must select a representative location of any test pits.;
- The approximate depth of the test pits is that which provides soil and water table information. This is a minimum of 0.9 m below the proposed infiltrative surface;
- Where bore holes are used, a minimum of one observation test pit should be excavated to confirm bore hole test results;
- The test pits are to be excavated and ramped in a manner that allows for safe entry for inspection without a ladder;
- Never enter a trench deeper than 1.2 metres (4 ft.) unless it is properly cut back, shored or protected by a trench box/cage designed by a professional engineer. Never enter an excavation deeper than 1.2 metres (4 ft.) and work closer to the wall than the depth of the excavation unless the wall is properly cut back, shored or protected by a temporary protective structure designed by a professional engineer. There may be cases where even a trench shallower than 1.2 meters requires additional safety considerations. See Occupational Health and Safety instructions in the publication “Safety in Excavations and Trenches” found at <http://www.labour.gov.sk.ca/ohs-publications/>.
- Test pits should minimize the impact on disposal and receiving areas from pits and machinery; and,
- Monitor at least one of the holes for a minimum of 24 hours and record the quantity of water that collects in the hole. If water appears try to determine the source.

Ensure that no services are located in the area prior to digging test pits and bore holes.

Call Sask 1st Call (1-866-828-4888) and other non-participating utilities prior to digging on the site.

APPENDIX 23 – CONSTRUCTION NOTES

Construction Notes

The effectiveness of any onsite system depends partially on the construction methodology. The following practices should be avoided: compaction of the infiltration area and area down gradient of the infiltration area; smearing of the soil surface; and construction during the winter months (with frozen soil). Sampling points, flow measuring devices, and inspection ports for all treatment units including the discharge area are encouraged.

APPENDIX 24 – SEWER & WATER LINE INSTALLATION

Ground water may enter a water distribution system when negative internal/positive external pressures occur. The entry of ground water may be through leaks or breaks in piping, vacuum-air relief valves, blow-offs, fire hydrants, meter systems, outlets, etc. Therefore the relative location of sewer lines and water lines and the types of material used for each system are important considerations in designing a sewage system to minimize the possibility of contamination entering the water piping.

Parallel Installation

Under normal conditions, sewer lines should be laid with at least 2.5 metres horizontal separation from any line.

Under unusual conditions (such as excessive rock, severe dewatering problems, congestion due to other utilities), a sewer line may be laid closer to a water line provided that the elevation of the crown of the sewer is at least 0.5 metres below the invert of the water line. The separation distance should be undisturbed native material or compacted backfill

Where unusual conditions and the vertical separation cannot be obtained, the sewer should be constructed of materials and joints equivalent to water line construction

Crossings

Under normal conditions sewer lines should cross under water lines with sufficient vertical separation to allow for proper bedding and structural support of both lines.

Where it is not possible for the sewer line to cross under the water line, a sewer line may be laid above a water line provided that:

- a) a vertical separation of at least 0.5 metres between the invert of the sewer line and the crown of the water line is maintained;
- b) adequate structural support for the sewer line is present to prevent excessive deflection of joints and settling
- c) the lengths of water line are centered at the point of the crossing so that the joints are equidistant and as far as possible from the sewer line.

There may be cases where local conditions do not permit the above guidelines to be met. In these cases, a number of factors can be considered when laying the water and sewer lines. This list of factors can be considered for guidance. This list is not all-inclusive.

- a) Materials, types of joints and identification for water and sewer pipes;
- b) Soil conditions, undisturbed native soil, backfilling and compaction techniques;
- c) Service and branch connections;
- d) Location of groundwater table;
- e) Location of septic tanks and private sewage systems;